

# S

**MOTORIDUTTORE PENDOLARE**  
**SHAFT MOUNTED GEARED MOTOR**  
**MOTORÉDUCTEUR PENDULAIRE**  
**FLACHGETRIEBEMOTOREN**  
**MOTORREDUCTOR PENDULAR**  
轴装式齿轮减速机



**MOTOVARIO®**  
HEART OF MOTION

Versioni / Versions / Versions /  
Ausführungen / Versiones / 版本

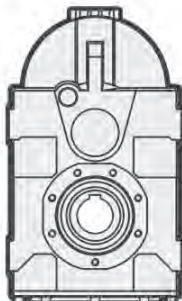
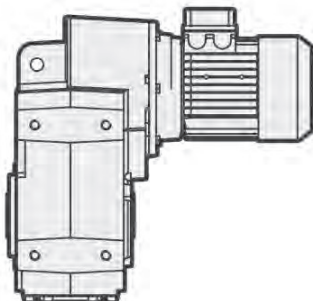
**S ... C**

- Fissaggio piede-flangia / albero cavo.
- Foot-flange mounting / hollow shaft.
- Fixation à pattes et bride / arbre creux.
- Fuß-Flanschbefestigung / Hohlwelle.
- Fijación patas-bridá / eje hueco.
- 底脚-法兰安装/空心轴.

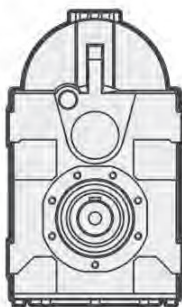
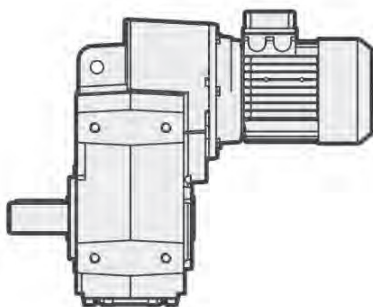
**S ... D**

- Fissaggio piede-flangia / albero pieno D.
- Foot-flange mounting / D solid shaft.
- Fixation à pattes et bride / arbre en D.
- Fuß-Flanschbefestigung / D Vollwelle.
- Fijación patas-bridá / eje macizo D.
- 底脚-法兰安装/D 实心轴.

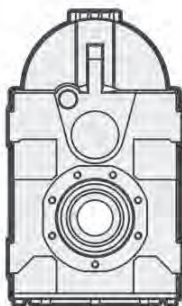
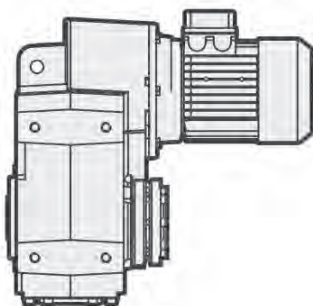
**S ... L**

- Fissaggio piede-flangia / albero calettatore.
- Foot-flange mounting / shrink disc shaft.
- Fixation à pattes / bride arbre avec frette.
- Fuß-Flanschbefestigung / Schrumpfscheibe.
- Fijación patas-bridá / eje hueco con aro de apriete.
- 底脚-法兰安装/锁紧盘轴.

**Predisposizione / Predisposition / Pr disposition /  
Motoranbau / Predisposici n / 预配置**
**CS - S - PS ...052**

i	071	080	090	100	112
8,63	B5-B11	B5-B11	B5-B11	B5-B11	B5-B11
11,14	B5-B11	B5-B11	B5-B11	B5-B11	B5-B11
13,66	B5-B11	B5-B11	B5-B11	B5-B11	B5-B11
15,27	B5-B11	B5-B11	B5-B11	B5-B11	B5-B11
16,29	B5-B11	B5-B11	B5-B11	B5-B11	B5-B11
18,63	B5-B11	B5-B11	B5-B11	B5-B11	B5-B11
21,04	B5-B11	B5-B11	B5-B11	B5-B11	B5-B11
24,07	B5-B11	B5-B11	B5-B11	B5-B11	B5-B11
25,79	B5-B11	B5-B11	B5-B11	B5-B11	B5-B11
27,81	B5-B11	B5-B11	B5-B11	B5-B11	B5-B11
30,00	B5-B11	B5-B11	B5-B11		
32,55	B5-B11	B5-B11	B5-B11	B5-B11	B5-B11
36,55	B5-B11	B5-B11	B5-B11		
39,90	B5-B11	B5-B11	B5-B11	B5-B11	B5-B11
42,63	B5-B11	B5-B11	B5-B11		
47,20	B5-B11	B5-B11	B5-B11		
52,25	B5-B11	B5-B11	B5-B11		
57,86	B5-B11	B5-B11	B5-B11		
72,83	B5-B11	B5-B11	B5-B11		

**CS - S - PS ...062**

i	071	080	090	100	112
8,00		B5-B11	B5-B11	B5-B11	B5-B11
9,55		B5-B11	B5-B11	B5-B11	B5-B11
11,71		B5-B11	B5-B11	B5-B11	B5-B11
13,36		B5-B11	B5-B11	B5-B11	B5-B11
15,94		B5-B11	B5-B11	B5-B11	B5-B11
19,55		B5-B11	B5-B11	B5-B11	B5-B11
23,18	B5-B11	B5-B11	B5-B11	B5-B11	B5-B11
25,14	B5-B11	B5-B11	B5-B11	B5-B11	B5-B11
27,66	B5-B11	B5-B11	B5-B11	B5-B11	B5-B11
30,00	B5-B11	B5-B11	B5-B11	B5-B11	B5-B11
33,93	B5-B11	B5-B11	B5-B11	B5-B11	B5-B11
36,57	B5-B11	B5-B11	B5-B11	B5-B11	B5-B11
39,38	B5-B11	B5-B11	B5-B11	B5-B11	B5-B11
43,64	B5-B11	B5-B11	B5-B11	B5-B11	B5-B11
46,10	B5-B11	B5-B11	B5-B11		
53,53	B5-B11	B5-B11	B5-B11	B5-B11	B5-B11
55,00	B5-B11	B5-B11	B5-B11		
67,47	B5-B11	B5-B11	B5-B11		

**CS - S - PS ...053**

i	063	071	080	090
74,20	B5-B11	B5-B11	B5-B11	B5-B11
95,84	B5-B11	B5-B11	B5-B11	B5-B11
117,48	B5-B11	B5-B11	B5-B11	B5-B11
137,45	B5-B11	B5-B11	B5-B11	B5-B11
177,55	B5-B11	B5-B11	B5-B11	B5-B11
198,45	B5-B11	B5-B11		
217,64	B5-B11	B5-B11	B5-B11	B5-B11
256,33	B5-B11	B5-B11		
314,21	B5-B11	B5-B11		

**CS - S - PS ...063**

i	071	080	090
81,43	B5-B11	B5-B11	B5-B11
99,89	B5-B11	B5-B11	B5-B11
126,43	B5-B11	B5-B11	B5-B11
150,85	B5-B11	B5-B11	B5-B11
185,05	B5-B11	B5-B11	B5-B11
217,79	B5-B11		
267,16	B5-B11		

B11 = Motori in esecuzione speciale  
 B11 = Motor with special execution  
 B11 = Moteurs avec exécution spéciale  
 B11 = Motoren mit Spezialgeometrie  
 B11 = Motores con ejecución especial  
 B11 = 特殊执行电机

- Motore gr.063 non esiste la versione PB
- For motor size 063 the PB version does not exist
- Veuillez svp remarquer: pour moteur taille 063 la version PB n'existe pas
- Bitte bemerken: mit Motor Baugröße 063 existiert die Ausführung PB nicht
- Para motor tamaño 063 no existe la versión PB
- 电机尺寸063无PB

- Le tabelle riportano la fattibilità dimensionale degli accoppiamenti. Verificare il fattore di servizio.
- These tables report all possible dimensions. Please verify service factor.
- Ces tableaux montrent toutes les combinaisons possibles. Prions vérifier le facteur de service.
- Diese Tabellen zeigen alle möglichen Dimensionen. Bitte prüfen sie daher die Betriebsfaktor.
- Rogamos considerar que tratase de tablas de combinaciones posibles. Verifiquen el factor de servicio.
- 请记住，时间是可能的组合。素需要非常密切地检查是否有足够的就业机会的因素。

Predisposizione / Predisposition / Pr disposition /  
Motoranbau / Predisposici n / 预配置

**CS - S - PS ...082**

i	080	090	100	112	132
7,34	B5-B11	B5-B11	B5-B11	B5-B11	B5-B11
8,06	B5-B11	B5-B11	B5-B11	B5-B11	B5-B11
9,94	B5-B11	B5-B11	B5-B11	B5-B11	B5-B11
11,61	B5-B11	B5-B11	B5-B11	B5-B11	B5-B11
12,75	B5-B11	B5-B11	B5-B11	B5-B11	B5-B11
15,73	B5-B11	B5-B11	B5-B11	B5-B11	B5-B11
17,29	B5-B11	B5-B11	B5-B11	B5-B11	B5-B11
20,14	B5-B11	B5-B11	B5-B11	B5-B11	B5-B11
22,13	B5-B11	B5-B11	B5-B11	B5-B11	B5-B11
24,00	B5-B11	B5-B11	B5-B11	B5-B11	B5-B11
27,29	B5-B11	B5-B11	B5-B11	B5-B11	B5-B11
28,67	B5-B11	B5-B11	B5-B11	B5-B11	B5-B11
31,78	B5-B11	B5-B11	B5-B11	B5-B11	B5-B11
34,91	B5-B11	B5-B11	B5-B11	B5-B11	B5-B11
40,05	B5-B11	B5-B11	B5-B11	B5-B11	
43,05	B5-B11	B5-B11	B5-B11	B5-B11	B5-B11
50,25	B5-B11	B5-B11	B5-B11	B5-B11	
54,27	B5-B11	B5-B11	B5-B11	B5-B11	
61,98	B5-B11	B5-B11	B5-B11	B5-B11	

**CS - S - PS ...102**

i	080	090	100	112	132	160
8,06	B5-B11	B5-B11	B5-B11	B5-B11	B5-B11	B5
8,85	B5-B11	B5-B11	B5-B11	B5-B11	B5-B11	B5
10,88	B5-B11	B5-B11	B5-B11	B5-B11	B5-B11	B5
12,75	B5-B11	B5-B11	B5-B11	B5-B11	B5-B11	B5
13,99	B5-B11	B5-B11	B5-B11	B5-B11	B5-B11	B5
17,21	B5-B11	B5-B11	B5-B11	B5-B11	B5-B11	B5
19,00	B5-B11	B5-B11	B5-B11	B5-B11	B5-B11	
22,13	B5-B11	B5-B11	B5-B11	B5-B11	B5-B11	
24,28	B5-B11	B5-B11	B5-B11	B5-B11	B5-B11	
26,33	B5-B11	B5-B11	B5-B11	B5-B11	B5-B11	
29,87	B5-B11	B5-B11	B5-B11	B5-B11	B5-B11	
32,40	B5-B11	B5-B11	B5-B11	B5-B11	B5-B11	
34,91	B5-B11	B5-B11	B5-B11	B5-B11	B5-B11	
38,30	B5-B11	B5-B11	B5-B11	B5-B11	B5-B11	
44,00	B5-B11	B5-B11	B5-B11	B5-B11		
47,13	B5-B11	B5-B11	B5-B11	B5-B11	B5-B11	
55,14	B5-B11	B5-B11	B5-B11	B5-B11		
59,40	B5-B11	B5-B11	B5-B11	B5-B11		
67,84	B5-B11	B5-B11	B5-B11	B5-B11		

**CS - S - PS ...083**

i	071	080	090	100	112
67,52		B5-B11	B5-B11	B5-B11	B5-B11
74,18		B5-B11	B5-B11	B5-B11	B5-B11
91,49		B5-B11	B5-B11	B5-B11	B5-B11
117,17	B5-B11	B5-B11	B5-B11		
128,73	B5-B11	B5-B11	B5-B11		
158,76	B5-B11	B5-B11	B5-B11		
184,88	B5-B11	B5-B11	B5-B11		
203,11	B5-B11	B5-B11	B5-B11		
250,50	B5-B11	B5-B11	B5-B11		
292,36	B5-B11	B5-B11	B5-B11		
315,73	B5-B11	B5-B11	B5-B11		
360,58	B5-B11	B5-B11	B5-B11		

**CS - S - PS ...103**

i	071	080	090	100	112
74,18		B5-B11	B5-B11	B5-B11	B5-B11
81,39		B5-B11	B5-B11	B5-B11	B5-B11
100,15		B5-B11	B5-B11	B5-B11	B5-B11
110,55	B5-B11	B5-B11	B5-B11	B5-B11	B5-B11
128,73	B5-B11	B5-B11	B5-B11	B5-B11	B5-B11
141,24	B5-B11	B5-B11	B5-B11	B5-B11	B5-B11
173,78	B5-B11	B5-B11	B5-B11	B5-B11	B5-B11
203,11	B5-B11	B5-B11	B5-B11	B5-B11	B5-B11
222,85	B5-B11	B5-B11	B5-B11	B5-B11	B5-B11
274,20	B5-B11	B5-B11	B5-B11	B5-B11	B5-B11
320,79	B5-B11	B5-B11	B5-B11		
345,60	B5-B11	B5-B11	B5-B11		
394,69	B5-B11	B5-B11	B5-B11		

B11 = Motori in esecuzione speciale  
 B11 = Motor with special execution  
 B11 = Moteurs avec exécution spéciale  
 B11 = Motoren mit Spezialgeometrie  
 B11 = Motores con ejecución especial  
 B11 = 特殊执行电机

- Le tabelle riportano la fattibilità dimensionale degli accoppiamenti. Verificare il fattore di servizio.
- These tables report all possible dimensions. Please verify service factor.
- Ces tableaux montrent toutes les combinaisons possibles. Prions vérifier le facteur de service.
- Diese Tabellen zeigen alle möglichen Dimensionen. Bitte prüfen sie daher die Betriebsfaktor.
- Rogamos considerar que tratase de tablas de combinaciones posibles. Verifiquen el factor de servicio.
- 请记住，时间是可能的组合。素需要非常密切地检查是否有足够的就业机会的因素。

Predisposizione / Predisposition / Pr disposition /  
Motoranbau / Predisposici n / 预配置

**CS - S - PS ...122**

i	080	090	100	112	132	160	180	200
8,48						B5	B5	B5
9,30						B5	B5	B5
11,42						B5	B5	B5
12,63						B5	B5	B5
13,84						B5	B5	B5
16,99						B5	B5	B5
21,25			B5-B11	B5-B11	B5-B11	B5	B5	
23,29			B5-B11	B5-B11	B5-B11	B5	B5	
26,15			B5-B11	B5-B11	B5-B11	B5	B5	
28,60			B5-B11	B5-B11	B5-B11	B5	B5	
30,51			B5-B11	B5-B11	B5-B11	B5	B5	
33,44			B5-B11	B5-B11	B5-B11	B5	B5	
35,20			B5-B11	B5-B11	B5-B11	B5	B5	
41,07			B5-B11	B5-B11	B5-B11	B5	B5	
43,60	B5	B5-B11	B5-B11	B5-B11	B5-B11			
49,04	B5	B5-B11	B5-B11	B5-B11	B5-B11			
53,75	B5	B5-B11	B5-B11	B5-B11	B5-B11			
66,00	B5	B5-B11	B5-B11	B5-B11	B5-B11			

**CS - S - PS ...123**

i	080	090	100	112	132
71,07			B5-B11	B5-B11	B5-B11
87,27			B5-B11	B5-B11	B5-B11
112,52	B5	B5-B11	B5-B11	B5-B11	B5-B11
123,33	B5	B5-B11	B5-B11	B5-B11	B5-B11
133,78	B5	B5-B11	B5-B11	B5-B11	B5-B11
151,43	B5	B5-B11	B5-B11	B5-B11	B5-B11
177,53	B5	B5-B11	B5-B11	B5-B11	B5-B11
194,59	B5	B5-B11	B5-B11	B5-B11	B5-B11
238,93	B5	B5-B11	B5-B11	B5-B11	B5-B11
280,10	B5	B5-B11	B5-B11	B5-B11	
301,16	B5	B5-B11	B5-B11	B5-B11	
343,93	B5	B5-B11	B5-B11	B5-B11	

B11 = Motori in esecuzione speciale  
 B11 = Motor with special execution  
 B11 = Moteurs avec exécution spéciale  
 B11 = Motoren mit Spezialgeometrie  
 B11 = Motores con ejecución especial  
 B11 = 特殊执行电机

- Le tabelle riportano la fattibilità dimensionale degli accoppiamenti. Verificare il fattore di servizio.
- These tables report all possible dimensions. Please verify service factor.
- Ces tableaux montrent toutes les combinaisons possibles. Prions vérifier le facteur de service.
- Diese Tabellen zeigen alle möglichen Dimensionen. Bitte prüfen sie daher die Betriebsfaktor.
- Rogamos considerar que tratase de tablas de combinaciones posibles. Verifiquen el factor de servicio.
- 请记住，时间是可能的组合。素需要非常密切地检查是否有足够的就业机会的因素。

## Piazzamento / Mounting positions / Pos. de montage / Einbaulage / Pos. de montaje / 安装位置

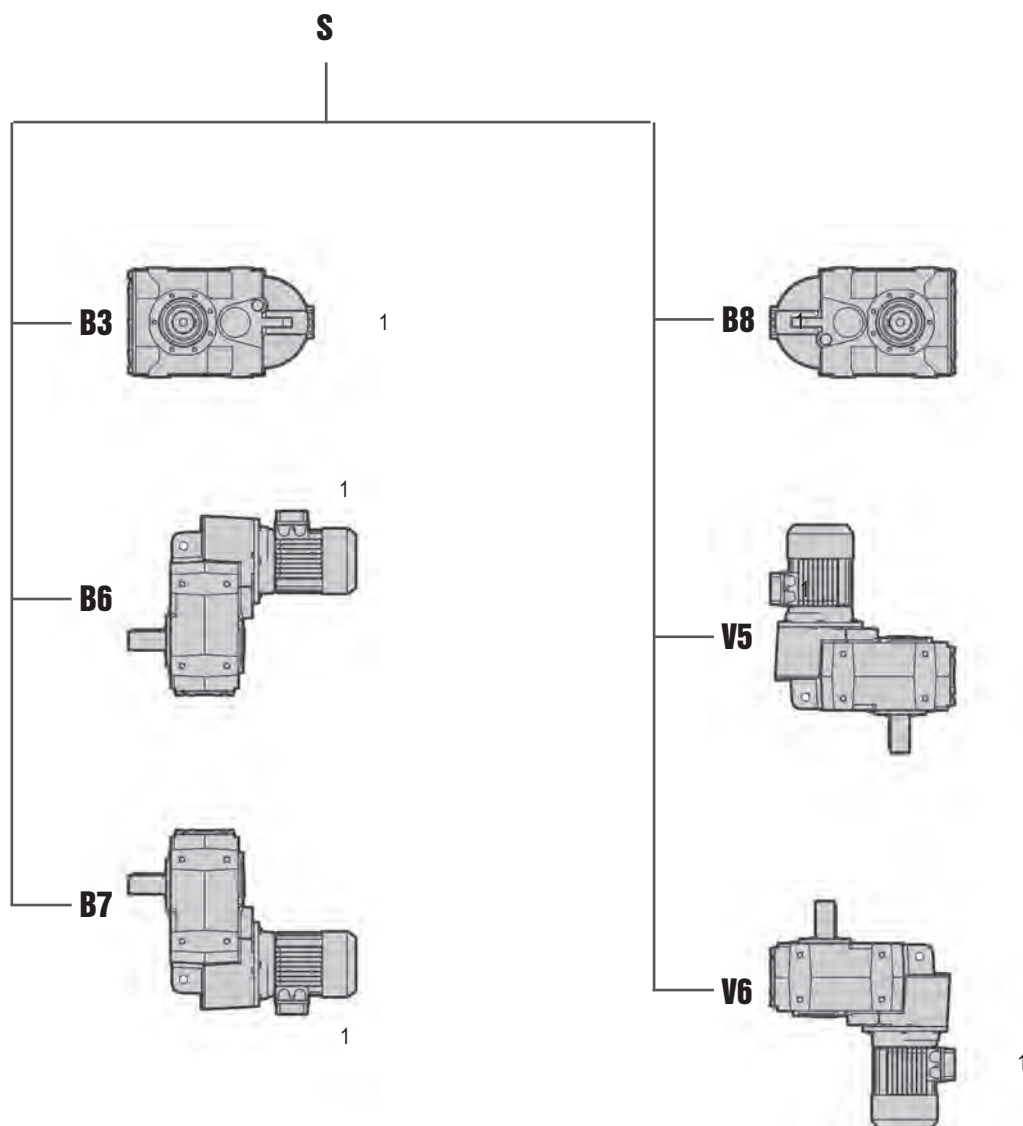



- Per le posizioni di piazzamento verticali verificare quanto detto a pag. 6.
- For vertical positions, check with pages 6.
- Pour les positions de montage verticales, voir pages 6.
- Für die vertikalen Einbaulagen siehe Seite 6.
- Para las posiciones de montaje verticales, ver las páginas 6.
- 对于垂直位置，应该检查第 6 页。

- Se non diversamente specificato le posizioni standard sono B3.
- Unless specified otherwise, the standard positions are B3.
- Si non spécifié, les positions standard sont B3.
- Falls nicht anders angegeben, sind B3 die Standardeinbaulagen.
- Si no se especifica lo contrario las posiciones estándar son B3.
- 除非另有其它规定，B3是标准位置。



- Per le posizioni di piazzamento non previste occorre rivolgersi al ns. Servizio tecnico.
- For positions not envisaged, it is necessary to call our Technical Service.
- Pour les positions de montage non prévues, contacter notre S.ce technique.
- Für nicht angegebene Einbaulagen setzen Sie sich bitte mit unserem Kundendienst in Verbindung.
- Para posiciones de montaje no previstas es necesario contactar con nuestro Servicio Técnico.
- 对于未列之位置，必须联系我们的服务技术部门。

S - Prestazioni / Performance / Performances / Leistungen / Prestaciones / 性能



**0,12 kW**

n2 [1/min]	M2 [Nm]	f.s.	i			Fr2 D [N]	Fr2 C-L [N]
7,9	137	2,6	177,55	S053	63A4	6000	6000
7,1	153	2,3	198,45	S053	63A4	6000	6000
6,4	167	2,1	217,64	S053	63A4	6000	6000
5,5	197	1,8	256,33	S053	63A4	6000	6000
4,5	242	1,4	314,21	S053	63A4	6000	6000



**0,18 kW**

n2 [1/min]	M2 [Nm]	f.s.	i			Fr2 D [N]	Fr2 C-L [N]
11,9	136	2,6	117,48	S053	63B4	6000	6000
10,2	159	2,2	137,45	S053	63B4	6000	6000
7,9	205	1,7	177,55	S053	63B4	6000	6000
7,1	229	1,5	198,45	S053	63B4	6000	6000
6,4	251	1,4	217,64	S053	63B4	6000	6000
5,5	296	1,2	256,33	S053	63B4	6000	6000
4,5	363	1,0	314,21	S053	63B4	6000	6000



**0,25 kW**

n2 [1/min]	M2 [Nm]	f.s.	i			Fr2 D [N]	Fr2 C-L [N]
14,6	154	2,3	95,84	S053	71A4	6000	6000
11,9	188	1,9	117,48	S053	71A4	6000	6000
10,2	220	1,6	137,45	S053	71A4	6000	6000
7,9	285	1,2	177,55	S053	71A4	6000	6000
7,1	318	1,1	198,45	S053	71A4	6000	6000
6,4	349	1,0	217,64	S053	71A4	6000	6000
5,5	411	0,9	256,33	S053	71A4	6000	6000
9,3	242	2,5	150,85	S063	71A4	10000	4000
7,6	297	2,0	185,05	S063	71A4	10000	4000
6,4	349	1,7	217,79	S063	71A4	10000	4000
5,2	428	1,4	267,16	S063	71A4	10000	4000
5,6	402	2,5	250,50	S083	71A4	18000	7200
4,8	469	2,1	292,36	S083	71A4	18000	7200
4,4	506	2,0	315,73	S083	71A4	18000	7200
3,9	578	1,7	360,58	S083	71A4	18000	7200



**0,37 kW**

n2 [1/min]	M2 [Nm]	f.s.	i			Fr2 D [N]	Fr2 C-L [N]
24,2	140	2,5	57,86	S052	71B4	6000	6000
19,2	176	2,0	72,83	S052	71B4	6000	6000
18,9	176	2,0	74,20	S053	71B4	6000	6000
14,6	227	1,5	95,84	S053	71B4	6000	6000
11,9	279	1,3	117,48	S053	71B4	6000	6000
10,2	326	1,1	137,45	S053	71B4	6000	6000
14,0	237	2,5	99,89	S063	71B4	10000	4000
11,1	300	2,0	126,43	S063	71B4	10000	4000



**0,37 kW**

n2 [1/min]	M2 [Nm]	f.s.	i			Fr2 D [N]	Fr2 C-L [N]
9,3	358	1,7	150,85	S063	71B4	10000	4000
7,6	439	1,4	185,05	S063	71B4	10000	4000
6,4	517	1,2	217,79	S063	71B4	10000	4000
5,2	634	0,9	267,16	S063	71B4	10000	4000
7,6	439	2,3	184,88	S083	71B4	18000	7200
6,9	482	2,1	203,11	S083	71B4	18000	7200
5,6	594	1,7	250,50	S083	71B4	18000	7200
4,8	694	1,4	292,36	S083	71B4	18000	7200
4,4	749	1,3	315,73	S083	71B4	18000	7200
3,9	855	1,2	360,58	S083	71B4	18000	7200
4,4	761	2,1	320,79	S103	71B4	22000	9000
4,1	820	2,0	345,60	S103	71B4	22000	9000
3,5	936	1,7	394,69	S103	71B4	22000	9000



**0,55 kW**

n2 [1/min]	M2 [Nm]	f.s.	i			Fr2 D [N]	Fr2 C-L [N]
32,8	154	2,3	42,63	S052	80A4	6000	6000
29,7	170	2,1	47,20	S052	80A4	6000	6000
26,8	188	1,9	52,25	S052	80A4	6000	6000
24,2	208	1,7	57,86	S052	80A4	6000	6000
19,2	262	1,3	72,83	S052	80A4	6000	6000
18,9	262	1,3	74,20	S053	80A4	6000	6000
14,6	338	1,0	95,84	S053	80A4	6000	6000
20,8	243	2,5	67,47	S062	80A4	10000	4000
17,2	287	2,1	81,43	S063	80A4	10000	4000
14,0	352	1,7	99,89	S063	80A4	10000	4000
11,1	446	1,3	126,43	S063	80A4	10000	4000
9,3	532	1,1	150,85	S063	80A4	10000	4000
10,9	454	2,2	128,73	S083	80A4	18000	9236
8,8	560	1,8	158,76	S083	80A4	18000	7200
7,6	652	1,5	184,88	S083	80A4	18000	7200
6,9	716	1,4	203,11	S083	80A4	18000	7200
5,6	883	1,1	250,50	S083	80A4	18000	7200
4,8	1031	1,0	292,36	S083	80A4	18000	7200
4,4	1113	0,9	315,73	S083	80A4	18000	7200
6,9	716	2,2	203,11	S103	80A4	22000	9000
6,3	786	2,0	222,85	S103	80A4	22000	9000
5,1	967	1,7	274,20	S103	80A4	22000	9000
4,4	1131	1,4	320,79	S103	80A4	22000	9000
4,1	1219	1,3	345,60	S103	80A4	22000	9000
3,5	1392	1,1	394,69	S103	80A4	22000	9000



**0,75 kW**

n2 [1/min]	M2 [Nm]	f.s.	i			Fr2 D [N]	Fr2 C-L [N]
46,7	147	2,0	30,00	S052	80B4	5727	5727
43,0	160	1,9	32,55	S052	80B4	5834	5834
38,3	179	1,8	36,55	S052	80B4	5983	5983
35,1	196	1,8	39,90	S052	80B4	6000	6000



**0,75 kW**

n2 [1/min]	M2 [Nm]	f.s.	i			Fr2 D [N]	Fr2 C-L [N]
32,8	209	1,7	42,63	S052	80B4	6000	6000
29,7	232	1,5	47,20	S052	80B4	6000	6000
26,8	257	1,4	52,25	S052	80B4	6000	6000
24,2	284	1,2	57,86	S052	80B4	6000	6000
19,2	358	1,0	72,83	S052	80B4	6000	6000
18,9	357	1,0	74,20	S053	80B4	6000	6000
26,2	263	2,3	53,53	S062	80B4	10000	4000
25,5	270	2,2	55,00	S062	80B4	10000	4000
20,8	331	1,8	67,47	S062	80B4	10000	4000
17,2	392	1,5	81,43	S063	80B4	10000	4000
14,0	480	1,2	99,89	S063	80B4	10000	4000
11,1	608	1,0	126,43	S063	80B4	10000	4000
11,9	564	1,8	117,17	S083	80B4	18000	8925
10,9	619	1,6	128,73	S083	80B4	18000	9236
8,8	764	1,3	158,76	S083	80B4	18000	7200
7,6	889	1,1	184,88	S083	80B4	18000	7200
6,9	977	1,0	203,11	S083	80B4	18000	7200
8,1	836	1,9	173,78	S103	80B4	22000	9000
6,9	977	1,6	203,11	S103	80B4	22000	9000
6,3	1072	1,5	222,85	S103	80B4	22000	9000
5,1	1319	1,2	274,20	S103	80B4	22000	9000
4,4	1543	1,0	320,79	S103	80B4	22000	9000
4,1	1662	1,0	345,60	S103	80B4	22000	9000
4,6	1448	2,1	301,16	S123	80B4	30000	11200
4,1	1654	1,8	343,93	S123	80B4	30000	11200



**0,92 kW**

n2 [1/min]	M2 [Nm]	f.s.	i			Fr2 D [N]	Fr2 C-L [N]
58,2	145	1,8	24,07	S052	80C4	5279	5279
54,3	155	1,9	25,79	S052	80C4	5360	5360
50,3	168	1,7	27,81	S052	80C4	5447	5447
46,7	181	1,6	30,00	S052	80C4	5533	5533
43,0	196	1,5	32,55	S052	80C4	5624	5624
38,3	220	1,5	36,55	S052	80C4	5747	5747
35,1	240	1,5	39,90	S052	80C4	5836	5836
32,8	257	1,4	42,63	S052	80C4	5900	5900
29,7	284	1,2	47,20	S052	80C4	5993	5993
26,8	315	1,1	52,25	S052	80C4	6000	6000
24,2	349	1,0	57,86	S052	80C4	6000	6000
30,4	278	2,2	46,10	S062	80C4	10000	4000
26,2	322	1,9	53,53	S062	80C4	10000	4000
25,5	331	1,8	55,00	S062	80C4	10000	4000
20,8	406	1,5	67,47	S062	80C4	10000	4000
17,2	480	1,2	81,43	S063	80C4	10000	4000
14,0	589	1,0	99,89	S063	80C4	10000	4000
15,3	540	1,9	91,49	S083	80C4	18000	8152
11,9	691	1,4	117,17	S083	80C4	18000	8925
10,9	759	1,3	128,73	S083	80C4	18000	9236
8,8	937	1,1	158,76	S083	80C4	18000	7200
7,6	1091	0,9	184,88	S083	80C4	18000	7200
10,9	759	2,1	128,73	S103	80C4	22000	11195
9,9	833	1,9	141,24	S103	80C4	22000	11580
8,1	1025	1,6	173,78	S103	80C4	22000	9000
6,9	1198	1,3	203,11	S103	80C4	22000	9000
6,3	1315	1,2	222,85	S103	80C4	22000	9000

**0,92 kW**



n2 [1/min]	M2 [Nm]	f.s.	i			Fr2 D [N]	Fr2 C-L [N]
5,1	1618	1,0	274,20	S103	80C4	22000	9000
5,0	1652	1,8	280,10	S123	80C4	30000	11200
4,6	1777	1,7	301,16	S123	80C4	30000	11200
4,1	2029	1,5	343,93	S123	80C4	30000	11200

**1,10 kW**



n2 [1/min]	M2 [Nm]	f.s.	i			Fr2 D [N]	Fr2 C-L [N]
102,5	98	2,1	13,66	S052	90S4	4506	4506
91,7	110	2,2	15,27	S052	90S4	4629	4629
86,0	117	2,0	16,29	S052	90S4	4700	4700
75,1	134	1,8	18,63	S052	90S4	4846	4846
66,6	152	1,7	21,04	S052	90S4	4975	4975
58,2	173	1,5	24,07	S052	90S4	5114	5114
54,3	186	1,6	25,79	S052	90S4	5183	5183
50,3	200	1,4	27,81	S052	90S4	5257	5257
46,7	216	1,3	30,00	S052	90S4	5328	5328
43,0	234	1,3	32,55	S052	90S4	5401	5401
38,3	263	1,3	36,55	S052	90S4	5497	5497
35,1	287	1,2	39,90	S052	90S4	5563	5563
32,8	307	1,1	42,63	S052	90S4	5608	5608
29,7	340	1,0	47,20	S052	90S4	5670	5670
26,8	376	0,9	52,25	S052	90S4	5719	5719
46,7	216	2,3	30,00	S062	90S4	9948	3979
41,3	244	2,2	33,93	S062	90S4	10000	4000
38,3	263	2,3	36,57	S062	90S4	10000	4000
35,6	284	2,1	39,38	S062	90S4	10000	4000
32,1	314	1,9	43,64	S062	90S4	10000	4000
30,4	332	1,8	46,10	S062	90S4	10000	4000
26,2	386	1,6	53,53	S062	90S4	10000	4000
25,5	396	1,5	55,00	S062	90S4	10000	4000
20,8	486	1,2	67,47	S062	90S4	10000	4000
17,2	574	1,0	81,43	S063	90S4	10000	4000
22,6	446	2,2	61,98	S082	90S4	18000	7055
20,7	476	2,1	67,52	S083	90S4	18000	7285
18,9	523	1,9	74,18	S083	90S4	18000	7544
15,3	645	1,5	91,49	S083	90S4	18000	8152
11,9	826	1,2	117,17	S083	90S4	18000	8925
10,9	908	1,1	128,73	S083	90S4	18000	9236
8,8	1120	0,9	158,76	S083	90S4	18000	7200
14,0	706	2,3	100,15	S103	90S4	22000	10211
12,7	780	2,1	110,55	S103	90S4	22000	10588
10,9	908	1,8	128,73	S103	90S4	22000	11195
9,9	996	1,6	141,24	S103	90S4	22000	11580
8,1	1226	1,3	173,78	S103	90S4	22000	9000
6,9	1433	1,1	203,11	S103	90S4	22000	9000
6,3	1572	1,0	222,85	S103	90S4	22000	9000
7,2	1372	2,2	194,59	S123	90S4	30000	11200
5,9	1685	1,8	238,93	S123	90S4	30000	11200
5,0	1976	1,5	280,10	S123	90S4	30000	11200
4,6	2124	1,4	301,16	S123	90S4	30000	11200
4,1	2426	1,2	343,93	S123	90S4	30000	11200





### 1,50 kW

n2 [1/min]	M2 [Nm]	f.s.	i			Fr2 D [N]	Fr2 C-L [N]
162,3	85	2,0	8,63	S052	90L4	3871	3871
125,7	109	1,7	11,14	S052	90L4	4112	4112
102,5	134	1,6	13,66	S052	90L4	4298	4298
91,7	150	1,6	15,27	S052	90L4	4397	4397
86,0	160	1,5	16,29	S052	90L4	4452	4452
75,1	183	1,3	18,63	S052	90L4	4562	4562
66,6	207	1,3	21,04	S052	90L4	4655	4655
58,2	236	1,1	24,07	S052	90L4	4748	4748
54,3	253	1,1	25,79	S052	90L4	4791	4791
50,3	273	1,1	27,81	S052	90L4	4834	4834
46,7	295	1,0	30,00	S052	90L4	4871	4871
43,0	320	0,9	32,55	S052	90L4	4905	4905
38,3	359	0,9	36,55	S052	90L4	4941	4941
35,1	392	0,9	39,90	S052	90L4	4956	4956
60,4	228	2,1	23,18	S062	90L4	8951	3581
55,7	247	1,9	25,14	S062	90L4	9112	3645
50,6	272	1,8	27,66	S062	90L4	9296	3719
46,7	295	1,7	30,00	S062	90L4	9450	3780
41,3	333	1,6	33,93	S062	90L4	9675	3870
38,3	359	1,7	36,57	S062	90L4	9806	3922
35,6	387	1,6	39,38	S062	90L4	9929	3972
32,1	429	1,4	43,64	S062	90L4	10000	4000
30,4	453	1,3	46,10	S062	90L4	10000	4000
26,2	526	1,1	53,53	S062	90L4	10000	4000
25,5	540	1,1	55,00	S062	90L4	10000	4000
20,8	663	0,9	67,47	S062	90L4	10000	4000
27,9	494	2,0	50,25	S082	90L4	18000	6521
25,8	533	1,9	54,27	S082	90L4	18000	6712
22,6	609	1,6	61,98	S082	90L4	18000	7055
20,7	649	1,5	67,52	S083	90L4	18000	7285
18,9	713	1,4	74,18	S083	90L4	18000	7544
15,3	880	1,1	91,49	S083	90L4	18000	8152
11,9	1127	0,9	117,17	S083	90L4	18000	8925
18,9	713	2,2	74,18	S103	90L4	22000	9136
17,2	783	2,0	81,39	S103	90L4	22000	9457
14,0	963	1,7	100,15	S103	90L4	22000	10211
12,7	1063	1,5	110,55	S103	90L4	22000	10588
10,9	1238	1,3	128,73	S103	90L4	22000	11195
9,9	1358	1,2	141,24	S103	90L4	22000	11580
8,1	1671	1,0	173,78	S103	90L4	22000	9000
10,5	1287	2,3	133,78	S123	90L4	30000	14693
9,2	1457	2,1	151,43	S123	90L4	30000	15442
7,9	1708	1,8	177,53	S123	90L4	30000	11200
7,2	1872	1,6	194,59	S123	90L4	30000	11200
5,9	2298	1,3	238,93	S123	90L4	30000	11200
5,0	2694	1,1	280,10	S123	90L4	30000	11200
4,6	2897	1,0	301,16	S123	90L4	30000	11200
4,1	3308	0,9	343,93	S123	90L4	30000	11200



### 1,84 kW

n2 [1/min]	M2 [Nm]	f.s.	i			Fr2 D [N]	Fr2 C-L [N]
162,3	104	1,6	8,63	S052	90LL4	3759	3759
125,7	134	1,4	11,14	S052	90LL4	3968	3968
102,5	165	1,3	13,66	S052	90LL4	4121	4121
91,7	184	1,3	15,27	S052	90LL4	4199	4199



### 1,84 kW

n2 [1/min]	M2 [Nm]	f.s.	i			Fr2 D [N]	Fr2 C-L [N]
86,0	196	1,2	16,29	S052	90LL4	4241	4241
75,1	224	1,1	18,63	S052	90LL4	4321	4321
66,6	253	1,0	21,04	S052	90LL4	4383	4383
58,2	290	0,9	24,07	S052	90LL4	4437	4437
54,3	311	0,9	25,79	S052	90LL4	4457	4457
50,3	335	0,9	27,81	S052	90LL4	4474	4474
71,6	236	2,0	19,55	S062	90LL4	8333	3333
60,4	279	1,7	23,18	S062	90LL4	8624	3450
55,7	303	1,6	25,14	S062	90LL4	8757	3503
50,6	333	1,4	27,66	S062	90LL4	8906	3562
46,7	361	1,4	30,00	S062	90LL4	9027	3611
41,3	409	1,3	33,93	S062	90LL4	9196	3678
38,3	441	1,4	36,57	S062	90LL4	9289	3716
35,6	474	1,3	39,38	S062	90LL4	9374	3749
32,1	526	1,1	43,64	S062	90LL4	9475	3790
30,4	555	1,1	46,10	S062	90LL4	9521	3808
26,2	645	0,9	53,53	S062	90LL4	9613	3845
25,5	663	0,9	55,00	S062	90LL4	9624	3849
35,0	483	2,1	40,05	S082	90LL4	18000	5983
32,5	519	1,9	43,05	S082	90LL4	18000	6150
27,9	605	1,7	50,25	S082	90LL4	18000	6521
25,8	654	1,5	54,27	S082	90LL4	18000	6712
22,6	747	1,3	61,98	S082	90LL4	18000	7055
20,7	797	1,3	67,52	S083	90LL4	18000	7285
18,9	875	1,1	74,18	S083	90LL4	18000	7544
15,3	1079	0,9	91,49	S083	90LL4	18000	8152
25,4	664	2,0	55,14	S102	90LL4	22000	8396
23,6	716	2,2	59,40	S102	90LL4	22000	8406
20,6	817	2,0	67,84	S102	90LL4	22000	8836
18,9	875	1,8	74,18	S103	90LL4	22000	9136
17,2	960	1,7	81,39	S103	90LL4	22000	9457
14,0	1182	1,4	100,15	S103	90LL4	22000	10211
12,7	1304	1,2	110,55	S103	90LL4	22000	10588
10,9	1519	1,1	128,73	S103	90LL4	22000	11195
9,9	1666	1,0	141,24	S103	90LL4	22000	11580
12,4	1328	2,3	112,52	S123	90LL4	30000	13697
11,4	1455	2,1	123,33	S123	90LL4	30000	14218
10,5	1578	1,9	133,78	S123	90LL4	30000	14693
9,2	1787	1,7	151,43	S123	90LL4	30000	11200
7,9	2095	1,4	177,53	S123	90LL4	30000	11200
7,2	2296	1,3	194,59	S123	90LL4	30000	11200
5,9	2819	1,1	238,93	S123	90LL4	30000	11200
5,0	3305	0,9	280,10	S123	90LL4	30000	11200



### 2,20 kW

n2 [1/min]	M2 [Nm]	f.s.	i			Fr2 D [N]	Fr2 C-L [N]
162,3	124	1,4	8,63	S052	100LA4	3641	3641
125,7	161	1,2	11,14	S052	100LA4	3815	3815
102,5	197	1,1	13,66	S052	100LA4	3934	3934
91,7	220	1,1	15,27	S052	100LA4	3990	3990
86,0	235	1,0	16,29	S052	100LA4	4018	4018
75,1	268	0,9	18,63	S052	100LA4	4066	4066
66,6	303	0,9	21,04	S052	100LA4	4095	4095
119,6	169	2,3	11,71	S062	100LA4	7228	2891
104,8	192	2,2	13,36	S062	100LA4	7446	2978



**2,20 kW**

n2 [1/min]	M2 [Nm]	f.s.	i			Fr2 D [N]	Fr2 C-L [N]
87,8	230	2,0	15,94	S062	100LA4	7731	3092
71,6	282	1,6	19,55	S062	100LA4	8041	3217
60,4	334	1,4	23,18	S062	100LA4	8278	3311
55,7	362	1,3	25,14	S062	100LA4	8381	3353
50,6	398	1,2	27,66	S062	100LA4	8493	3397
46,7	432	1,2	30,00	S062	100LA4	8579	3431
41,3	489	1,1	33,93	S062	100LA4	8689	3476
38,3	527	1,1	36,57	S062	100LA4	8743	3497
35,6	567	1,1	39,38	S062	100LA4	8785	3514
32,1	629	1,0	43,64	S062	100LA4	8823	3529
51,3	393	2,3	27,29	S082	100LA4	18000	5253
44,1	458	2,2	31,78	S082	100LA4	18000	5474
40,1	503	2,0	34,91	S082	100LA4	18000	5676
35,0	577	1,7	40,05	S082	100LA4	18000	5983
32,5	620	1,6	43,05	S082	100LA4	18000	6150
27,9	724	1,4	50,25	S082	100LA4	18000	6521
25,8	782	1,3	54,27	S082	100LA4	18000	6712
22,6	893	1,1	61,98	S082	100LA4	18000	7055
20,7	953	1,0	67,52	S083	100LA4	18000	7285
18,9	1046	1,0	74,18	S083	100LA4	18000	7544
31,8	634	2,1	44,00	S102	100LA4	22000	7724
29,7	679	2,4	47,13	S102	100LA4	22000	7701
25,4	794	1,6	55,14	S102	100LA4	22000	8396
23,6	856	1,9	59,40	S102	100LA4	22000	8406
20,6	977	1,6	67,84	S102	100LA4	22000	8836
18,9	1046	1,5	74,18	S103	100LA4	22000	9136
17,2	1148	1,4	81,39	S103	100LA4	22000	9457
14,0	1413	1,1	100,15	S103	100LA4	22000	10211
12,7	1559	1,0	110,55	S103	100LA4	22000	10588
12,4	1587	1,9	112,52	S123	100LA4	30000	13697
11,4	1740	1,7	123,33	S123	100LA4	30000	14218
10,5	1887	1,6	133,78	S123	100LA4	30000	14693
9,2	2136	1,4	151,43	S123	100LA4	30000	11200
7,9	2504	1,2	177,53	S123	100LA4	30000	11200
7,2	2745	1,1	194,59	S123	100LA4	30000	11200
5,9	3371	0,9	238,93	S123	100LA4	30000	11200



**3,00 kW**

n2 [1/min]	M2 [Nm]	f.s.	i			Fr2 D [N]	Fr2 C-L [N]
162,3	169	1,0	8,63	S052	100LB4	3379	3379
125,7	219	0,9	11,14	S052	100LB4	3476	3476
175,0	157	2,1	8,00	S062	100LB4	6321	2528
146,7	188	1,9	9,55	S062	100LB4	6568	2627
119,6	230	1,7	11,71	S062	100LB4	6839	2736
104,8	262	1,6	13,36	S062	100LB4	7003	2801
87,8	313	1,4	15,94	S062	100LB4	7201	2881
71,6	384	1,2	19,55	S062	100LB4	7392	2957
60,4	455	1,0	23,18	S062	100LB4	7508	3003
55,7	494	1,0	25,14	S062	100LB4	7546	3019
50,6	543	0,9	27,66	S062	100LB4	7574	3030
80,9	340	2,3	17,29	S082	100LB4	17245	4523
69,5	396	1,9	20,14	S082	100LB4	18000	4794
63,3	435	1,8	22,13	S082	100LB4	18000	4939
58,3	471	1,7	24,00	S082	100LB4	18000	5094
51,3	536	1,7	27,29	S082	100LB4	18000	5253



**3,00 kW**

n2 [1/min]	M2 [Nm]	f.s.	i			Fr2 D [N]	Fr2 C-L [N]
48,8	563	1,6	28,67	S082	100LB4	18000	5354
44,1	624	1,6	31,78	S082	100LB4	18000	5474
40,1	686	1,5	34,91	S082	100LB4	18000	5676
35,0	787	1,3	40,05	S082	100LB4	18000	5983
32,5	846	1,2	43,05	S082	100LB4	18000	6150
27,9	987	1,0	50,25	S082	100LB4	18000	6521
25,8	1066	0,9	54,27	S082	100LB4	18000	6712
40,1	686	2,0	34,91	S102	100LB4	22000	7011
36,6	752	2,0	38,30	S102	100LB4	22000	7187
31,8	864	1,5	44,00	S102	100LB4	22000	7724
29,7	926	1,7	47,13	S102	100LB4	22000	7701
25,4	1083	1,2	55,14	S102	100LB4	22000	8396
23,6	1167	1,4	59,40	S102	100LB4	22000	8406
20,6	1333	1,2	67,84	S102	100LB4	22000	8836
18,9	1427	1,1	74,18	S103	100LB4	22000	9136
17,2	1566	1,0	81,39	S103	100LB4	22000	9457
28,5	963	2,5	49,04	S122	100LB4	30000	10285
26,0	1056	2,5	53,75	S122	100LB4	30000	10464
21,2	1297	2,3	66,00	S122	100LB4	30000	10962
19,7	1367	2,0	71,07	S123	100LB4	30000	11638
16,0	1679	1,8	87,27	S123	100LB4	30000	12334
12,4	2164	1,4	112,52	S123	100LB4	30000	13697
11,4	2372	1,3	123,33	S123	100LB4	30000	14218
10,5	2573	1,2	133,78	S123	100LB4	30000	14693
9,2	2913	1,0	151,43	S123	100LB4	30000	11200
7,9	3415	0,9	177,53	S123	100LB4	30000	11200



**4,00 kW**

n2 [1/min]	M2 [Nm]	f.s.	i			Fr2 D [N]	Fr2 C-L [N]
175,0	210	1,6	8,00	S062	112M4	5989	2396
146,7	250	1,4	9,55	S062	112M4	6171	2469
119,6	307	1,3	11,71	S062	112M4	6353	2541
104,8	350	1,2	13,36	S062	112M4	6448	2579
87,8	417	1,1	15,94	S062	112M4	6540	2616
71,6	512	0,9	19,55	S062	112M4	6581	2632
89,0	412	1,9	15,73	S082	112M4	16441	4361
80,9	453	1,7	17,29	S082	112M4	16873	4523
69,5	528	1,5	20,14	S082	112M4	17574	4794
63,3	580	1,4	22,13	S082	112M4	18000	4939
58,3	629	1,3	24,00	S082	112M4	18000	5094
51,3	715	1,3	27,29	S082	112M4	18000	5253
48,8	751	1,2	28,67	S082	112M4	18000	5354
44,1	832	1,2	31,78	S082	112M4	18000	5474
40,1	914	1,1	34,91	S082	112M4	18000	5676
35,0	1049	1,0	40,05	S082	112M4	18000	5983
32,5	1128	0,9	43,05	S082	112M4	18000	6150
46,9	782	1,9	29,87	S102	112M4	22000	6533
43,2	849	1,8	32,40	S102	112M4	22000	6741
40,1	914	1,5	34,91	S102	112M4	22000	7011
36,6	1003	1,5	38,30	S102	112M4	22000	7187
31,8	1153	1,1	44,00	S102	112M4	22000	7724
29,7	1234	1,3	47,13	S102	112M4	22000	7701
28,5	1285	1,9	49,04	S122	112M4	30000	10285
26,0	1408	1,8	53,75	S122	112M4	30000	10464
21,2	1729	1,7	66,00	S122	112M4	30000	10962



### 4,00 kW

n2 [1/min]	M2 [Nm]	f.s.	i			Fr2 D [N]	Fr2 C-L [N]
19,7	1823	1,5	71,07	S123	112M4	30000	11638
16,0	2238	1,3	87,27	S123	112M4	30000	12334
12,4	2886	1,0	112,52	S123	112M4	30000	13697
11,4	3163	0,9	123,33	S123	112M4	30000	14218



### 4,80 kW

n2 [1/min]	M2 [Nm]	f.s.	i			Fr2 D [N]	Fr2 C-L [N]
175,0	251	1,3	8,00	S062	112MS4	5723	2289
146,7	300	1,2	9,55	S062	112MS4	5855	2342
119,6	368	1,1	11,71	S062	112MS4	5964	2386
104,8	420	1,0	13,36	S062	112MS4	6005	2402
87,8	501	0,9	15,94	S062	112MS4	6011	2404
120,6	365	1,9	11,61	S082	112MS4	14898	3942
109,8	401	1,9	12,75	S082	112MS4	15287	4040
89,0	494	1,6	15,73	S082	112MS4	16170	4361
80,9	544	1,4	17,29	S082	112MS4	16575	4523
69,5	633	1,2	20,14	S082	112MS4	17228	4794
63,3	695	1,2	22,13	S082	112MS4	17631	4939
58,3	754	1,1	24,00	S082	112MS4	17980	5094
51,3	858	1,0	27,29	S082	112MS4	18000	5253
48,8	901	1,0	28,67	S082	112MS4	18000	5354
44,1	999	1,0	31,78	S082	112MS4	18000	5474
40,1	1097	0,9	34,91	S082	112MS4	18000	5676
73,7	597	2,3	19,00	S102	112MS4	21498	5547
63,3	695	2,0	22,13	S102	112MS4	22000	5886
57,7	763	2,0	24,28	S102	112MS4	22000	6028
53,2	828	1,8	26,33	S102	112MS4	22000	6222
46,9	939	1,6	29,87	S102	112MS4	22000	6533
43,2	1018	1,5	32,40	S102	112MS4	22000	6741
40,1	1097	1,3	34,91	S102	112MS4	22000	7011
36,6	1204	1,2	38,30	S102	112MS4	22000	7187
31,8	1383	0,9	44,00	S102	112MS4	22000	7724
34,1	1291	2,3	41,07	S122	112MS4	30000	8903
28,5	1541	1,6	49,04	S122	112MS4	30000	10285
26,0	1690	1,5	53,75	S122	112MS4	30000	10464
21,2	2075	1,4	66,00	S122	112MS4	30000	10962
19,7	2187	1,2	71,07	S123	112MS4	30000	11638
16,0	2686	1,1	87,27	S123	112MS4	30000	12334



### 5,50 kW

n2 [1/min]	M2 [Nm]	f.s.	i			Fr2 D [N]	Fr2 C-L [N]
190,8	264	2,1	7,34	S082	132S4	12969	3437
173,6	290	2,1	8,06	S082	132S4	13319	3515
140,8	358	1,8	9,94	S082	132S4	14120	3760
120,6	418	1,7	11,61	S082	132S4	14723	3942
109,8	459	1,6	12,75	S082	132S4	15095	4040
89,0	566	1,4	15,73	S082	132S4	15933	4361
80,9	623	1,2	17,29	S082	132S4	16315	4523
69,5	725	1,1	20,14	S082	132S4	16925	4794
63,3	797	1,0	22,13	S082	132S4	17298	4939
58,3	864	0,9	24,00	S082	132S4	17618	5094



### 5,50 kW

n2 [1/min]	M2 [Nm]	f.s.	i			Fr2 D [N]	Fr2 C-L [N]
51,3	983	0,9	27,29	S082	132S4	18000	5253
48,8	1033	0,9	28,67	S082	132S4	18000	5354
44,1	1144	0,9	31,78	S082	132S4	18000	5474
128,6	392	2,4	10,88	S102	132S4	18160	4775
109,8	459	2,2	12,75	S102	132S4	19014	5032
100,1	504	2,4	13,99	S102	132S4	19526	5063
81,3	620	2,1	17,21	S102	132S4	20700	5410
73,7	684	2,0	19,00	S102	132S4	21272	5547
63,3	797	1,8	22,13	S102	132S4	22000	5886
57,7	874	1,7	24,28	S102	132S4	22000	6028
53,2	948	1,6	26,33	S102	132S4	22000	6222
46,9	1076	1,4	29,87	S102	132S4	22000	6533
43,2	1167	1,3	32,40	S102	132S4	22000	6741
40,1	1257	1,1	34,91	S102	132S4	22000	7011
36,6	1380	1,1	38,30	S102	132S4	22000	7187
45,9	1099	2,7	30,51	S122	132S4	30000	7768
41,9	1205	2,5	33,44	S122	132S4	30000	8107
34,1	1479	2,0	41,07	S122	132S4	30000	8903
32,1	1570	1,9	43,60	S122	132S4	30000	9145
28,5	1766	1,4	49,04	S122	132S4	30000	10285
26,0	1936	1,3	53,75	S122	132S4	30000	10464
21,2	2377	1,3	66,00	S122	132S4	30000	10962
19,7	2506	1,1	71,07	S123	132S4	30000	11638
16,0	3078	1,0	87,27	S123	132S4	30000	12334



### 7,50 kW

n2 [1/min]	M2 [Nm]	f.s.	i			Fr2 D [N]	Fr2 C-L [N]
190,8	360	1,5	7,34	S082	132L4	12653	3437
173,6	396	1,5	8,06	S082	132L4	12972	3515
140,8	488	1,3	9,94	S082	132L4	13692	3760
120,6	570	1,2	11,61	S082	132L4	14224	3942
109,8	626	1,2	12,75	S082	132L4	14547	4040
89,0	772	1,0	15,73	S082	132L4	15256	4361
173,6	396	2,1	8,06	S102	132L4	16342	4332
158,3	434	2,1	8,85	S102	132L4	16782	4450
128,6	535	1,8	10,88	S102	132L4	17790	4775
109,8	626	1,6	12,75	S102	132L4	18580	5032
100,1	687	1,7	13,99	S102	132L4	19051	5063
81,3	845	1,5	17,21	S102	132L4	20115	5410
73,7	933	1,5	19,00	S102	132L4	20627	5547
63,3	1087	1,3	22,13	S102	132L4	21416	5886
57,7	1192	1,3	24,28	S102	132L4	21895	6028
53,2	1293	1,2	26,33	S102	132L4	22000	6222
46,9	1467	1,0	29,87	S102	132L4	22000	6533
43,2	1591	0,9	32,40	S102	132L4	22000	6741
53,5	1285	2,3	26,15	S122	132L4	30000	7222
49,0	1405	2,1	28,60	S122	132L4	30000	7535
45,9	1499	2,0	30,51	S122	132L4	30000	7768
41,9	1643	1,8	33,44	S122	132L4	30000	8107
39,8	1729	1,7	35,20	S122	132L4	30000	8300
34,1	2017	1,5	41,07	S122	132L4	30000	8903
32,1	2141	1,4	43,60	S122	132L4	30000	9145
28,5	2408	1,0	49,04	S122	132L4	30000	10285
26,0	2640	1,0	53,75	S122	132L4	30000	10464
21,2	3242	0,9	66,00	S122	132L4	30000	10962



**9,20 kW**

n2 [1/min]	M2 [Nm]	f.s.	i			Fr2 D [N]	Fr2 C-L [N]
190,8	442	1,2	7,34	S082	132M4	12385	3437
173,6	486	1,2	8,06	S082	132M4	12678	3515
140,8	599	1,1	9,94	S082	132M4	13328	3760
120,6	699	1,0	11,61	S082	132M4	13800	3942
109,8	768	1,0	12,75	S082	132M4	14080	4040
173,6	486	1,7	8,06	S102	132M4	16109	4332
158,3	533	1,7	8,85	S102	132M4	16526	4450
128,6	656	1,4	10,88	S102	132M4	17476	4775
109,8	768	1,3	12,75	S102	132M4	18212	5032
100,1	843	1,4	13,99	S102	132M4	18646	5063
81,3	1037	1,3	17,21	S102	132M4	19618	5410
73,7	1145	1,2	19,00	S102	132M4	20078	5547
63,3	1333	1,1	22,13	S102	132M4	20777	5886
57,7	1463	1,0	24,28	S102	132M4	21194	6028
53,2	1587	0,9	26,33	S102	132M4	21552	6222
65,9	1280	2,2	21,25	S122	132M4	29365	6745
60,1	1403	2,1	23,29	S122	132M4	29950	6937
53,5	1576	1,9	26,15	S122	132M4	30000	7222
49,0	1723	1,7	28,60	S122	132M4	30000	7535
45,9	1838	1,6	30,51	S122	132M4	30000	7768
41,9	2015	1,5	33,44	S122	132M4	30000	8107
39,8	2121	1,4	35,20	S122	132M4	30000	8300
34,1	2474	1,2	41,07	S122	132M4	30000	8903
32,1	2627	1,1	43,60	S122	132M4	30000	9145



**11,00 kW**

n2 [1/min]	M2 [Nm]	f.s.	i			Fr2 D [N]	Fr2 C-L [N]
173,6	581	1,5	8,06	S102	160M4	15862	4332
158,3	637	1,4	8,85	S102	160M4	16256	4450
128,6	784	1,2	10,88	S102	160M4	17143	4775
109,8	918	1,1	12,75	S102	160M4	17822	5032
100,1	1008	1,2	13,99	S102	160M4	18218	5063
81,3	1240	1,0	17,21	S102	160M4	19091	5410
165,0	611	2,5	8,48	S122	160M4	22955	5596
150,6	670	2,5	9,30	S122	160M4	23509	5602
122,6	822	2,3	11,42	S122	160M4	24757	5907
110,9	910	2,4	12,63	S122	160M4	25368	5851
101,2	997	2,4	13,84	S122	160M4	25923	5888
82,4	1224	2,1	16,99	S122	160M4	27144	6266
65,9	1531	1,8	21,25	S122	160M4	28416	6745
60,1	1678	1,7	23,29	S122	160M4	28910	6937
53,5	1884	1,6	26,15	S122	160M4	29504	7222
49,0	2060	1,5	28,60	S122	160M4	29934	7535
45,9	2198	1,4	30,51	S122	160M4	30000	7768
41,9	2409	1,2	33,44	S122	160M4	30000	8107
39,8	2536	1,2	35,20	S122	160M4	30000	8300
34,1	2958	1,0	41,07	S122	160M4	30000	8903
32,1	3140	1,0	43,60	S122	160M4	30000	9145



**15,00 kW**

n2 [1/min]	M2 [Nm]	f.s.	i			Fr2 D [N]	Fr2 C-L [N]
173,6	792	1,1	8,06	S102	160L4	15314	4332
158,3	869	1,0	8,85	S102	160L4	15654	4450
165,0	833	1,8	8,48	S102	160L4	22113	5596
150,6	913	1,9	9,30	S122	160L4	22586	5602
122,6	1121	1,7	11,42	S122	160L4	23624	5907
110,9	1240	1,8	12,63	S122	160L4	24116	5851
101,2	1359	1,8	13,84	S122	160L4	24550	5888
82,4	1669	1,6	16,99	S122	160L4	25458	6266
65,9	2087	1,3	21,25	S122	160L4	26307	6745
60,1	2288	1,3	23,29	S122	160L4	26599	6937
53,5	2569	1,2	26,15	S122	160L4	26909	7222
49,0	2809	1,1	28,60	S122	160L4	27096	7535
45,9	2997	1,0	30,51	S122	160L4	27199	7768
41,9	3285	0,9	33,44	S122	160L4	27293	8107
39,8	3458	0,9	35,20	S122	160L4	27317	8300

**18,50 kW**

n2 [1/min]	M2 [Nm]	f.s.	i			Fr2 D [N]	Fr2 C-L [N]
165,0	1028	1,5	8,48	S122	180M4	21376	5596
150,6	1126	1,5	9,30	S122	180M4	21779	5602
122,6	1383	1,4	11,42	S122	180M4	22633	5907
110,9	1530	1,4	12,63	S122	180M4	23019	5851
101,2	1677	1,4	13,84	S122	180M4	23348	5888
82,4	2059	1,3	16,99	S122	180M4	23983	6266
65,9	2574	1,1	21,25	S122	180M4	24462	6745
60,1	2822	1,0	23,29	S122	180M4	24577	6937
53,5	3169	0,9	26,15	S122	180M4	24638	7222
49,0	3465	0,9	28,60	S122	180M4	24613	7535

**22,00 kW**

n2 [1/min]	M2 [Nm]	f.s.	i			Fr2 D [N]	Fr2 C-L [N]
165,0	1222	1,2	8,48	S122	180L4	20640	5596
150,6	1339	1,3	9,30	S122	180L4	20972	5602
122,6	1645	1,2	11,42	S122	180L4	21641	5907
110,9	1819	1,2	12,63	S122	180L4	21923	5851
101,2	1994	1,2	13,84	S122	180L4	22147	5888
82,4	2448	1,1	16,99	S122	180L4	22507	6266
65,9	3061	0,9	21,25	S122	180L4	22617	6745
60,1	3356	0,9	23,29	S122	180L4	22555	6937

**IS - Prestazioni / Performance / Performances / Leistungen / Prestaciones / 性能 (n1=1400 rpm)**
**IS052**

M2 [Nm]	i	P1 [kW]	n2 [1/min]	Fr1 [N]	Fr2 D [N]	Fr2 C-L [N]
170	8,63	3,01	162,3	718	3375	3375
190	11,14	2,60	125,7	810	3644	3644
210	13,66	2,35	102,5	869	3857	3857
240	15,27	2,40	91,7	857	3874	3874
240	16,29	2,25	86,0	891	3987	3987
240	18,63	1,97	75,1	956	4231	4231
260	21,04	1,89	66,6	974	4345	4345
260	24,07	1,65	58,2	1029	4611	4611
290	25,79	1,72	54,3	1013	4578	4578
290	27,81	1,59	50,3	1042	4736	4736
290	30,00	1,48	46,7	1069	4898	4898
300	32,55	1,41	43,0	1084	5020	5020
330	36,55	1,38	38,3	1091	5109	5109
350	39,90	1,34	35,1	1100	5200	5200
350	42,63	1,25	32,8	1119	5359	5359
350	47,20	1,13	29,7	1147	5612	5612
350	52,25	1,02	26,8	1172	5873	5873
350	57,86	0,92	24,2	1195	6000	6000
350	72,83	0,73	19,2	1238	6000	6000

**IS053**

M2 [Nm]	i	P1 [kW]	n2 [1/min]	Fr1 [N]	Fr2 D [N]	Fr2 C-L [N]
350	74,20	0,74	18,9	1242	6000	6000
350	95,84	0,57	14,6	1279	6000	6000
350	117,48	0,46	11,9	1302	6000	6000
350	137,45	0,40	10,2	1317	6000	6000
350	177,55	0,31	7,9	1338	6000	6000
350	198,45	0,28	7,1	1345	6000	6000
350	217,64	0,25	6,4	1350	6000	6000
350	256,33	0,21	5,5	1359	6000	6000
350	314,21	0,17	4,5	1367	6000	6000

**IS062**

M2 [Nm]	i	P1 [kW]	n2 [1/min]	Fr1 [N]	Fr2 D [N]	Fr2 C-L [N]
330	8,00	6,30	175,0	350	5225	2090
360	9,55	5,76	146,7	441	5474	2190
390	11,71	5,09	119,6	554	5825	2330
420	13,36	4,80	104,8	602	6004	2401
450	15,94	4,31	87,8	684	6334	2533
460	19,55	3,59	71,6	805	6911	2764
470	23,18	3,10	60,4	888	7415	2966
480	25,14	2,92	55,7	919	7635	3054
480	27,66	2,65	50,6	963	7976	3190
500	30,00	2,55	46,7	981	8149	3260
540	33,93	2,43	41,3	1000	8364	3346
600	36,57	2,51	38,3	988	8280	3312
600	39,38	2,33	35,6	1018	8578	3431
600	43,64	2,10	32,1	1056	9005	3602

**IS062**

M2 [Nm]	i	P1 [kW]	n2 [1/min]	Fr1 [N]	Fr2 D [N]	Fr2 C-L [N]
600	46,10	1,99	30,4	1075	9239	3695
600	53,53	1,71	26,2	1121	9898	3959
600	55,00	1,67	25,5	1129	10000	4000
600	67,47	1,36	20,8	1181	10000	4000

**IS063**

M2 [Nm]	i	P1 [kW]	n2 [1/min]	Fr1 [N]	Fr2 D [N]	Fr2 C-L [N]
600	81,43	1,15	17,2	1220	10000	4000
600	99,89	0,94	14,0	1255	10000	4000
600	126,43	0,74	11,1	1287	10000	4000
600	150,85	0,62	9,3	1307	10000	4000
600	185,05	0,51	7,6	1326	10000	4000
600	217,79	0,43	6,4	1338	10000	4000
600	267,16	0,35	5,2	1351	10000	4000

**IS082**

M2 [Nm]	i	P1 [kW]	n2 [1/min]	Fr1 [N]	Fr2 D [N]	Fr2 C-L [N]
550	7,34	11,44	190,8	1261	12030	3437
600	8,06	11,36	173,6	1273	12302	3515
650	9,94	9,98	140,8	1482	13161	3760
700	11,61	9,21	120,6	1598	13797	3942
750	12,75	8,98	109,8	1632	14140	4040
770	15,73	7,48	89,0	1859	15264	4361
770	17,29	6,80	80,9	1962	15832	4523
770	20,14	5,84	69,5	2107	16778	4794
800	22,13	5,52	63,3	2154	17288	4939
800	24,00	5,09	58,3	2219	17830	5094
900	27,29	5,04	51,3	2228	18000	5253
900	28,67	4,79	48,8	2264	18000	5354
1000	31,78	4,81	44,1	2262	18000	5474
1000	34,91	4,37	40,1	2327	18000	5676
1000	40,05	3,81	35,0	2412	18000	5983
1000	43,05	3,55	32,5	2452	18000	6150
1000	50,25	3,04	27,9	2529	18000	6521
1000	54,27	2,81	25,8	2563	18000	6712
1000	61,98	2,46	22,6	2616	18000	7055

**IS083**

M2 [Nm]	i	P1 [kW]	n2 [1/min]	Fr1 [N]	Fr2 D [N]	Fr2 C-L [N]
1000	67,52	2,31	20,7	2646	18000	7285
1000	74,18	2,10	18,9	2677	18000	7544
1000	91,49	1,70	15,3	2735	18000	8152
1000	117,17	1,33	11,9	2791	18000	8925
1000	128,73	1,21	10,9	2808	18000	9236

**IS083**

M2 [Nm]	i	P1 [kW]	n2 [1/min]	Fr1 [N]	Fr2 D [N]	Fr2 C-L [N]
1000	158,76	0,98	8,8	2842	18000	7200
1000	184,88	0,84	7,6	2863	18000	7200
1000	203,11	0,77	6,9	2874	18000	7200
1000	250,50	0,62	5,6	2895	18000	7200
1000	292,36	0,53	4,8	2908	18000	7200
1000	315,73	0,49	4,4	2914	18000	7200
1000	360,58	0,43	3,9	2923	18000	7200

**IS102**

M2 [Nm]	i	P1 [kW]	n2 [1/min]	Fr1 [N]	Fr2 D [N]	Fr2 C-L [N]
850	8,06	16,10	173,6	647	15163	4332
900	8,85	15,54	158,3	729	15574	4450
950	10,88	13,33	128,6	1050	16712	4775
1000	12,75	11,98	109,8	1247	17610	5032
1200	13,99	13,10	100,1	1084	17719	5063
1300	17,21	11,53	81,3	1311	18935	5410
1400	19,00	11,25	73,7	1352	19415	5547
1400	22,13	9,66	63,3	1583	20603	5886
1500	24,28	9,44	57,7	1616	21097	6028
1500	26,33	8,70	53,2	1724	21777	6222
1500	29,87	7,67	46,9	1873	22000	6533
1500	32,40	7,07	43,2	1961	22000	6741
1400	34,91	6,12	40,1	2098	22000	7011
1500	38,30	5,98	36,6	2119	22000	7187
1300	44,00	4,51	31,8	2333	22000	7724
1600	47,13	5,18	29,7	2235	22000	7701
1300	55,14	3,60	25,4	2465	22000	8396
1600	59,40	4,11	23,6	2391	22000	8406
1600	67,84	3,60	20,6	2465	22000	8836

**IS103**

M2 [Nm]	i	P1 [kW]	n2 [1/min]	Fr1 [N]	Fr2 D [N]	Fr2 C-L [N]
1600	74,18	3,36	18,9	2510	22000	9136
1600	81,39	3,07	17,2	2552	22000	9457
1600	100,15	2,49	14,0	2634	22000	10211
1600	110,55	2,26	12,7	2667	22000	10588
1600	128,73	1,94	10,9	2713	22000	11195
1600	141,24	1,77	9,9	2737	22000	11580
1600	173,78	1,44	8,1	2784	22000	9000
1600	203,11	1,23	6,9	2814	22000	9000
1600	222,85	1,12	6,3	2829	22000	9000
1600	274,20	0,91	5,1	2859	22000	9000
1600	320,79	0,78	4,4	2878	22000	9000
1600	345,60	0,72	4,1	2886	22000	9000
1600	394,69	0,63	3,5	2899	22000	9000

**IS122**

M2 [Nm]	i	P1 [kW]	n2 [1/min]	Fr1 [N]	Fr2 D [N]	Fr2 C-L [N]
1500	8,48	27,00	165,0	2951	19587	5596
1700	9,30	27,92	150,6	2916	19606	5602
1900	11,42	25,41	122,6	3010	20674	5907
2200	12,63	26,61	110,9	2966	20480	5851
2400	13,84	26,48	101,2	2970	20608	5888
2600	16,99	23,36	82,4	3087	21932	6266
2800	21,25	20,12	65,9	3209	23608	6745
2900	23,29	19,01	60,1	3251	24280	6937
3000	26,15	17,52	53,5	3252	25277	7222
3000	28,60	16,02	49,0	3253	26374	7535
3000	30,51	15,01	45,9	3254	27189	7768
3000	33,44	13,70	41,9	3255	28374	8107
3000	35,20	13,01	39,8	3256	29050	8300
3000	41,07	11,16	34,1	3257	30000	8903
3000	43,60	10,51	32,1	3258	30000	9145
2400	49,04	7,47	28,5	3685	30000	10285
2600	53,75	7,39	26,0	3688	30000	10464
3000	66,00	6,94	21,2	3705	30000	10962

**IS123**

M2 [Nm]	i	P1 [kW]	n2 [1/min]	Fr1 [N]	Fr2 D [N]	Fr2 C-L [N]
2700	71,07	5,92	19,7	3748	30000	11638
3000	87,27	5,36	16,0	3768	30000	12334
3000	112,52	4,16	12,4	3813	30000	13697
3000	123,33	3,79	11,4	3826	30000	14218
3000	133,78	3,50	10,5	3827	30000	14693
3000	151,43	3,09	9,2	3852	30000	11200
3000	177,53	2,64	7,9	3869	30000	11200
3000	194,59	2,40	7,2	3877	30000	11200
3000	238,93	1,96	5,9	3894	30000	11200
3000	280,10	1,67	5,0	3904	30000	11200
3000	301,16	1,55	4,6	3908	30000	11200
3000	343,93	1,36	4,1	3915	30000	11200

S/CS... - Dimensioni / Dimensions / Encombremets /  
Abmessungen / Dimensiones / 尺寸

CS..C

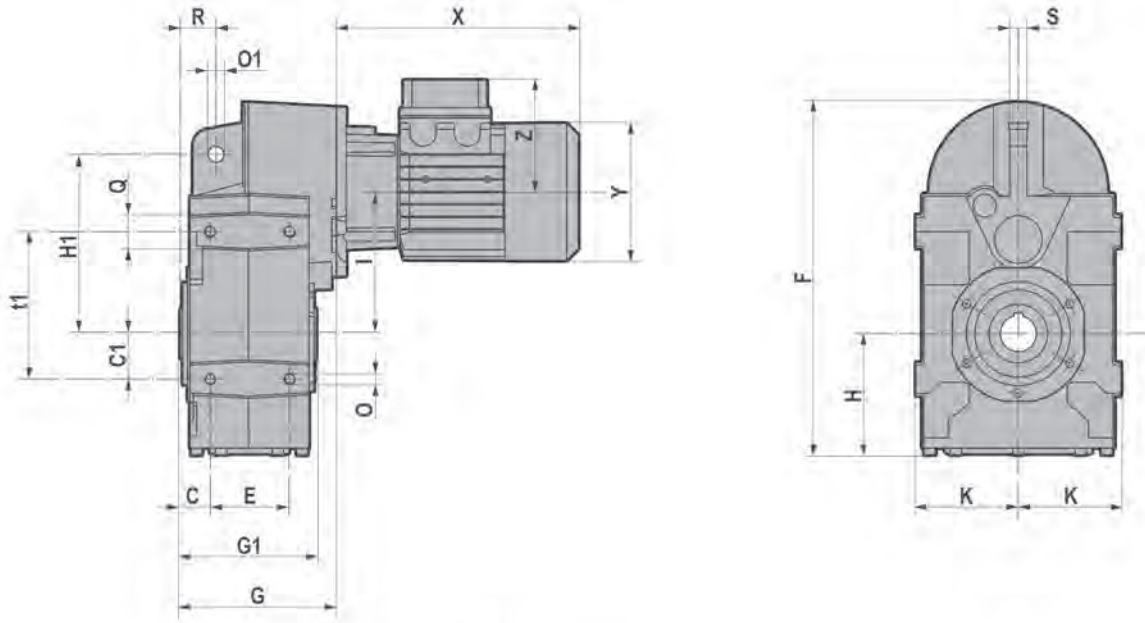

CS..D

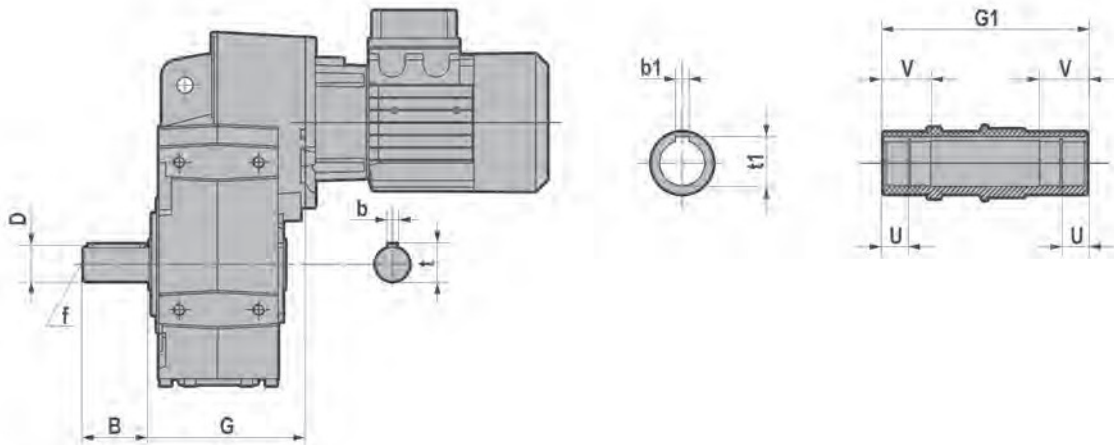

S/CS...	D1	b1	t1	U	V	B	D	b	t	f	C	C1	E
050	30	8	33.3	13.8	30	58	30 j6	8	33	M10	26.5	40	70
060	35	10	38.3	12	35	58	35 j6	10	38	M12	30	45	80
080	40	12	43.3	22.25	42	80	40 k6	12	43	M16	37	60	106
100	50	14	53.8	25	50	100	50 k6	14	53.5	M16	36.5	70	137
125	60	18	64.4	28	70	120	60 m6	18	64	M20	43	100	165

S/CS...	E1	G	G	G1	H	H1	I	K	O	O1	Q	R	S
050	130	311	137.5	120	107	158	125	90.5	M10x18	14	30	31.5	15
060	147	320	158.5	140	97	170	143	96.5	M12x20	14	40	32	15
080	190	383	207	180	107	218	170	112.5	M12x20	14	44	41	20
100	275	426	217.5	210	119	278	180	130	M16x26	22	50	50	20
125	310	549	257	240	157	346	235	165	M16x30	22	50	62	26

- Per le dimensioni relative alla zona attacco motore (X, Y, Z) fare riferimento alla tabella di pag. 37.
- For the dimensions concerning the motor connection area (X, Y, Z) please refer to the table shown at page 37.
- Pour les dimensions concernant la zone de montage du moteur (X, Y, Z) lire SVP le tableau à la page 37.
- Zu den Abmessungen des Motoranschlußflansches (X, Y, Z) siehe Tabelle auf Seite 37.
- Para las dimensiones correspondientes a la zona del motor (X, Y, Z) consulte la tabla de la página 37.
- 由于输出范围关系到电机的接线范围 (X, Y, Z), 请参考第 37 页上的表格

## S/CS...F - Dimensioni / Dimensions / Encombrements / Abmessungen / Dimensiones / 尺寸

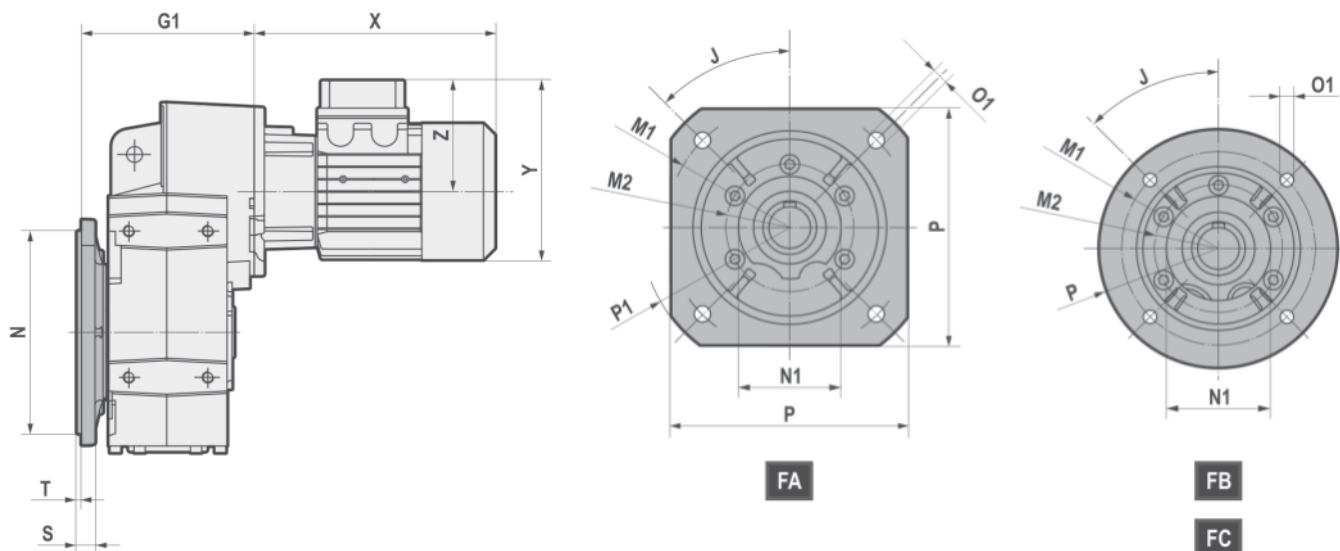

S..F		J	M1	M2	N	N1	O1	P	P1	S	T	G1
050	FA	45	215	105	180 f8	90	14	200	250	12	4	153
	FB	45	165	105	130 f8	90	11	200	/	12	3,5	
060	FA	45	215	105	180 f8	90	14	200	250	12	4	172,5
	FB	45	165	105	130 f8	90	11	200	/	12	3,5	
080	FA	45	265	130	230 f8	110	14	250	300	15	4	227
	FB	45	215	130	180 f8	110	14	250	/	15	4	
	FC	45	165	130	130 f8	110	11	200	/	15	3,5	
100	FA	45	300	165	250 f8	130	18	300	350	16	5	247,5
	FB	45	265	165	230 f8	130	14	300	/	16	4	
	FC	45	215	165	180 f8	130	14	250	/	16	4	
125	FB	45	300	185	250 f8	150	18	350	/	18	5	287
	FC	45	265	185	230 f8	150	14	300	/	18	4	

- Per le dimensioni relative alla zona attacco motore (X, Y, Z) fare riferimento alla tabella di pag. 37.
- For the dimensions concerning the motor connection area (X, Y, Z) please refer to the table shown at page 37.
- Pour les dimensions concernant la zone de montage du moteur (X, Y, Z) lire SVP le tableau à la page 37.
- Zu den Abmessungen des Motoranschlußflansches (X, Y, Z) siehe Tabelle auf Seite 37.
- Para las dimensiones correspondientes a la zona del motor (X, Y, Z) consulte la tabla de la página 37.
- 由于输出范围关系到电机的接线范围 (X, Y, Z), 请参考第 37 页上的表格



**CS.. - Dimensioni / Dimensions / Encombremets /  
Abmessungen / Dimensiones / 尺寸**
**CS...**

T - Motore / Motor / Moteur / Motor / Motor / 电机

CS		063	071	080	090S	090L	100	112	132S	132M
050 - 060	X	215	241	268	296	321	333	351	/	/
	Y	121	139	158	173	173	191	211	/	/
	Z	104	112	122	130	130	139	154	/	/
080 - 100	X	/	221	248	276	301	335	356	405	443
	Y	/	139	158	173	173	191	211	249	249
	Z	/	112	122	130	130	139	154	194	194
125	X	/	/	/	267	292	326	347	396	434
	Y	/	/	/	173	173	191	211	249	249
	Z	/	/	/	130	130	139	154	194	194

TB - Motore autofrenante / Brake motor / Moteur frein / Bremsmotor / Motor-freno / 制动电机

CS		063	071	080	090S	090L	100	112	132S	132M
050 - 060	X	273	306.5	341	373	398	415	448	/	/
	Y	121	139	158	173	173	191	211	/	/
	Z	104	112	122	130	130	139	154	/	/
080 - 100	X	/	286.5	321	353	378	417	453	505	547
	Y	/	139	158	173	173	191	211	249	249
	Z	/	112	122	130	130	139	154	194	194
125	X	/	/	/	343	368	407	443	495	537
	Y	/	/	/	173	173	191	211	249	249
	Z	/	/	/	130	130	139	154	194	194

**Peso / Weight / Poids / Gewicht / Peso / 重量 - (kg)**

T - Motore / Motor / Moteur / Motor / Motor / 电机

CS	063	071	080	090S	090L	100	112	132S	132M
050	19.5	20.4	25.1	29	31	36.5	48	/	/
060	/	23.9	28.7	32.6	34.6	40.1	51.6	/	/
080	/	36.5	41.6	44	45.5	50.6	62	76	87.6
100	/	47.5	52.6	55	56.5	61.6	73	87	98.6
125	/	/	/	91	92	98	108	123	132

TB - Motore autofrenante / Brake motor / Moteur frein / Bremsmotor / Motor-freno / 制动电机

CS	063	071	080	090S	090L	100	112	132S	132M
050	21	22.6	28.6	34.5	36.5	42	57.7	/	/
060	/	26.2	32.2	38.1	40.1	45.6	61.3	/	/
080	/	38.7	45	49.5	51	56	71.7	86.3	102.3
100	/	49.7	56	60.5	62	67	82.7	97.3	113.3
125	/	/	/	96.5	97.5	103.5	117.7	133.3	146.7

- Kg senza olio
- Kg w/o oil
- Kg sans huile
- Kg ohne Öl
- Kg sin aceite
- Kg 无油

## S/PS..2/3 - Dimensioni / Dimensions / Encombremets / Abmessungen / Dimensiones / 尺寸

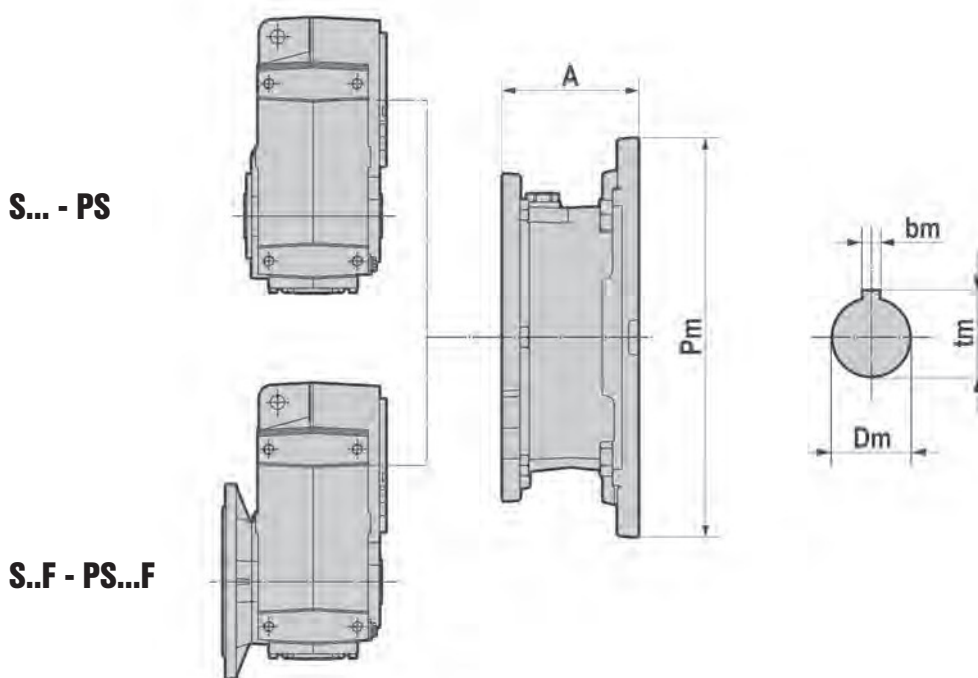

S PS	A		
	050-060	080-100	125
063	57	/	/
071	69	49	/
080-090	90	70	60,5
100-112	105	85	75,5
132	/	110	100,5
160	/	157,5	148
180	/	157,5	148
200	/	/	185

- Per le dimensioni relative alla zona attacco motore (Pm, Dm, bm, tm) fare riferimento alla tabella di pag. 40.
- For the dimensions concerning the motor connection area (Pm, Dm, bm, tm) please refer to the table shown at page 40.
- Pour les dimensions concernant la zone de montage du moteur (Pm, Dm, bm, tm) lire SVP le tableau à la page 40.
- Zu den Abmessungen des Motoranschlußflansches (Pm, Dm, bm, tm) siehe Tabelle auf Seite 40.
- Para las magnitudes correspondientes a la zona del motor (Pm, Dm, bm, tm) consulte la tabla de la página 40.
- 有关电机连接区域的尺寸 (Pm, Dm, bm, tm), 请参阅第 40 页上所示的表格。

- Kg senza olio
- Kg w/o oil
- Kg sans huile
- Kg ohne Öl
- Kg sin aceite
- Kg 无油

### Peso / Weight / Poid / Gewicht / Peso / 重量 - (kg)

S PS	050	060	080	100	125
063	16	/	/	/	/
071	16,4	19,9	32,9	44	/
080-090	17	20,6	35	46	82
100-112	21,2	24,9	37	48	84,2
132	/	/	39,7	50,7	87
160-180	/	/	/	57,4	93
200	/	/	/	/	108

(kg) senza motore e olio / w/o motor and oil / sans moteur et huile / ohne Motor und Öl / sin motor y aceite / 无机油

IS..2/3 - Dimensioni / Dimensions / Encombremets /  
Abmessungen / Dimensiones / 尺寸

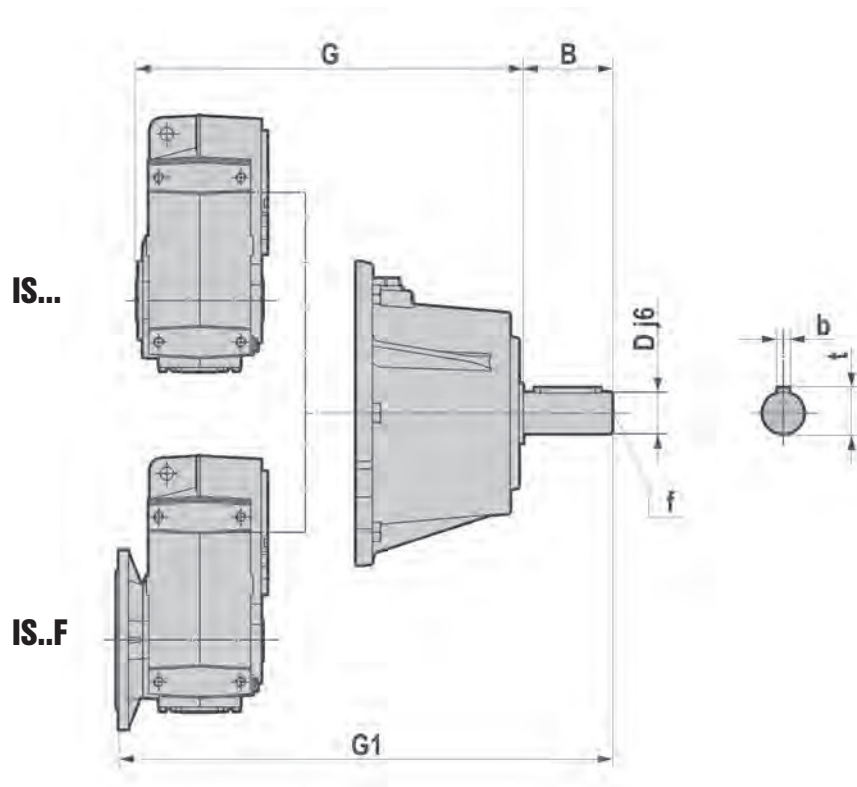

IS	G	G1	B	D	b	t	f
050	227.5	243	50	24 j6	8	27	M8
060	248.5	262.5					
080	320	340	60	28 j6	8	31	M10
100	330.5	360.5					
125	383.5	413.5	80	38 k6	10	41	M12

Peso / Weight / Poid / Gewicht / Peso / 重量 - (kg)

IS	~ Kg
050	19,2
060	22,7
080	39
100	50
125	91,8

- Kg senza olio
- Kg w/o oil
- Kg sans huile
- Kg ohne Öl
- Kg sin aceite
- Kg 无油

## PAM B5 - Dimensioni / Dimensions / Encombremets / Abmessungen / Dimensiones / 尺寸

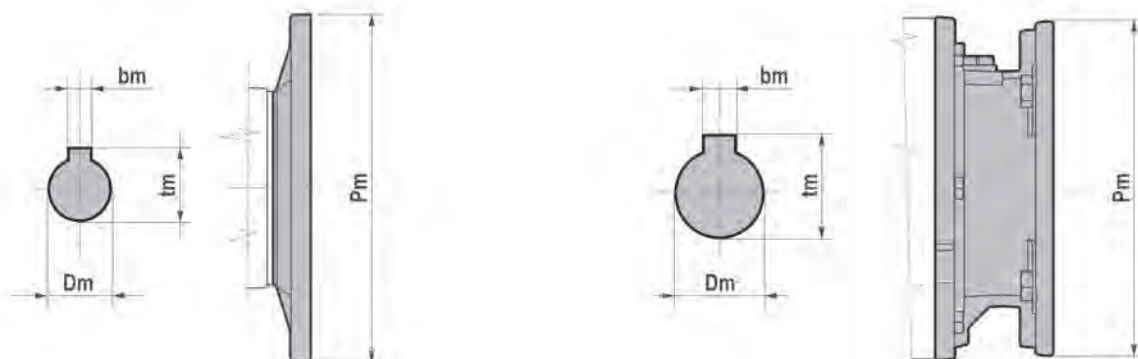

B5	IEC										
	063	071	080	090	100	112	132	160	180	200	225
<b>Pm</b>	140	160	200	200	250	250	300	350	350	400	450
<b>Dm</b>	11	14	19	24	28	28	38	42	48	55	60
<b>bm</b>	4	5	6	8	8	8	10	12	14	16	18
<b>tm</b>	12,8	16,3	21,8	27,3	31,3	31,3	41,3	45,3	51,8	59,3	64,4

## Posizione morsettiera / Position of terminal box / Position du bornier / Klemmenkastenlage / Posición caja de bornes / 接线盒位置

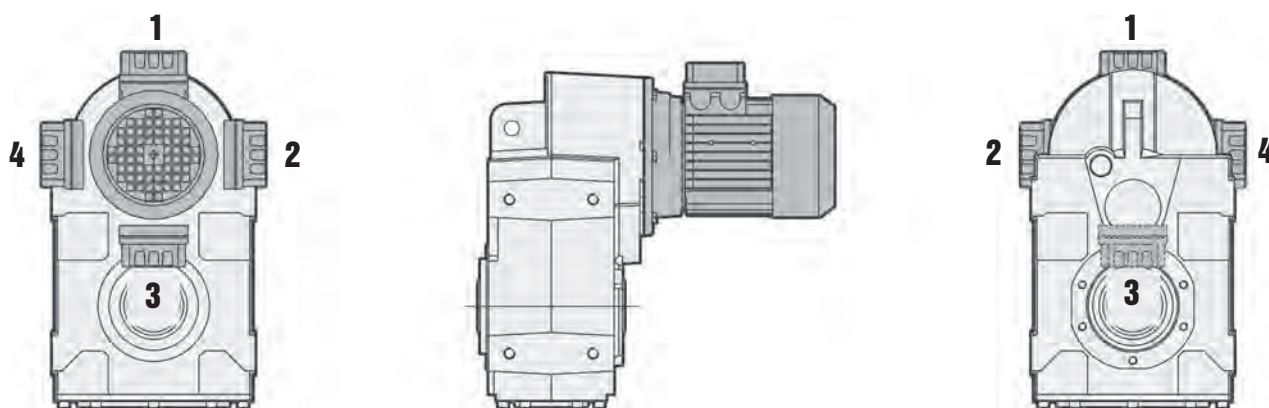

- Se non diversamente specificato in fase d'ordine, il gruppo viene fornito con morsettiera in pos. 1.
- Unless otherwise specified when ordering, the gear reducer is supplied with terminal box in position 1.
- Sauf indications contraires lors de la commande, le réducteur est fourni avec boîte à borne en position 1.
- Sofern in der Bestellung nicht anders spezifiziert, wird der Schneckengetriebemotor mit Klemmkastenlage 1 geliefert.
- De no especificarse lo contrario en el pedido, el motorreductor se monta con caja de bornes en posición 1.
- 除非订货时另有说明，齿轮减速机将在位置 (1) 处配备接线盒

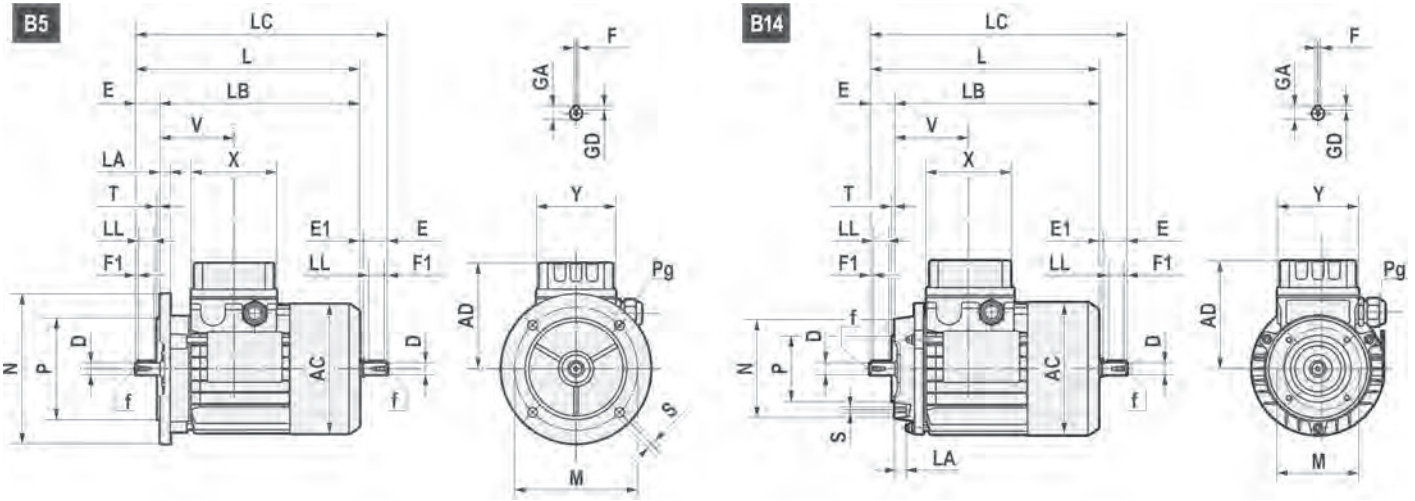
**Motori elettrici / Electric motors / Moteurs électriques / Elektromotoren / Motores eléctricos / 电机**

	AC	AD	L	LB	LC	X	Y	V	D	E	E1	f	F1	GA	F	GD	LL	Pg		
																		ø min	ø max	
<b>63</b>	121	103,5	211	188	235,5	80	74	69	11 j6	23	1,5	M4x10	2,5	12,5	4	4	15	M16x1,5	5	10
<b>71</b>	139	112	238,5	208,5	271	80	74	74,5	14 j6	30	2,5	M5x12,5	3	16	5	5	20	M20x1,5	6	12
<b>80</b>	158	121,5	272,5	232,5	314	80	74	78	19 j6	40	1,5	M6x16	5	21,5	6	6	30	M20x1,5	6	12
<b>90S</b>	173	129,5	298	248	349,5	98	98	89,5	24 j6	50	1,5	M8x19	5	27	8	7	35	M25x1,5	9	17
<b>90L</b>	173	129,5	323	273	374,5	98	98	89,5	24 j6	50	1,5	M8x19	5	27	8	7	35	M25x1,5	9	17
<b>100</b>	191	138,5	368	308	431,5	98	98	97,5	28 j6	60	2,5	M10x22	7,5	31	8	7	45	M25x1,5	9	17
<b>112</b>	210,5	153,5	382,5	322,5	447	98	98	100	28 j6	60	1,5	M10x22	7,5	31	8	7	45	M25x1,5	9	17
<b>132S</b>	248,4	194	452	382	536,5	118	118	115,5	38 k6	80	4	M12x28	10	41	10	8	60	M32x1,5	11	21
<b>132M/L</b>	248,4	194	490	410	574,5	118	118	115,5	38 k6	80	4	M12x28	10	41	10	8	60	M32x1,5	11	21

B5	M	N	P	LA	S	T
<b>63</b>	115	95 j6	140	9,5	9	3
<b>71</b>	130	110 j6	160	10	9,5	3,5
<b>80</b>	165	130 j6	200	12	11	3,5
<b>90</b>	165	130 j6	200	12	11	3,5
<b>100</b>	215	180 j6	250	15	14	4
<b>112</b>	215	180 j6	250	14,5	14	4
<b>132</b>	265	230 j6	300	20	14	3,5

B14	M	N	P	LA	S	T
<b>63</b>	75	60 j6	90	10,5	M5	2,5
<b>71</b>	85	70 j6	105	10,5	M6	2,5
<b>80</b>	100	80 j6	120	10,5	M6	3
<b>90</b>	115	95 j6	140	11,5	M8	3
<b>100</b>	130	110 j6	160	15	M8	3,5
<b>112</b>	130	110 j6	160	11,5	M8	3,5
<b>132</b>	165	130 j6	200	20,5	M10	3,5

**Potenza nominale (kW) / Nominal power (kW) / Puissance nominale (kW) / Nennleistung (kW) / Potencia nominal (kW) / 标称功率 (kW)**

	63A	63B	63C	71A	71B	71C	80A	80B	80C	90S
<b>2(*)</b>	0,18	0,25	0,37	0,37	0,55	0,75	0,75	1,1	1,5	1,5
<b>4(*)</b>	0,12	0,18	0,22	0,25	0,37	0,55	0,55	0,75	0,92	1,1
<b>6(*)</b>	0,09	0,12	0,15	0,18	0,25	0,37	0,37	0,55	0,75	0,75
<b>8(*)</b>			0,07	0,09	0,12	0,18	0,18	0,25	0,37	0,37
	90L	90LL	100LA	100LB	112M	112MS	132SA	132SB	132L	132M
<b>2(*)</b>	2,2		3	4	4	5,5	5,5	7,5	9,2	11
<b>4(*)</b>	1,5	1,84	2,2	3	4	4,8	5,5		7,5	9,2
<b>6(*)</b>	1,1		1,5	1,85	2,2	3	3		4	5,5
<b>8(*)</b>	0,55		0,75	1,1	1,5		2,2		3	

(\*) Poli / Poles / Pôles / Pole / Polos / 极性

**Flangia / Flange / Flasque /  
Flansch / Brida / 法兰**

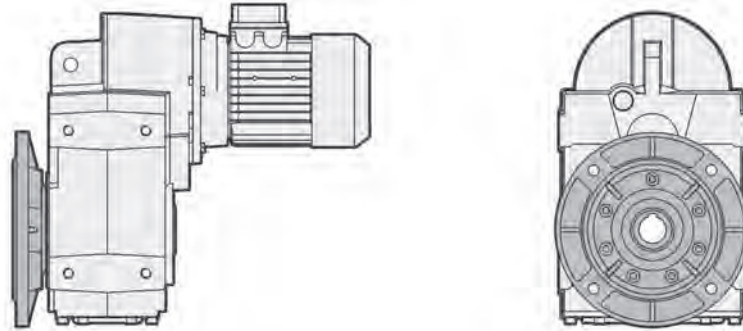

**Braccio di reazione / Torque arm / Bras de réaction /  
Drehmomentstütze / Brazo de reacción / 扭矩臂**

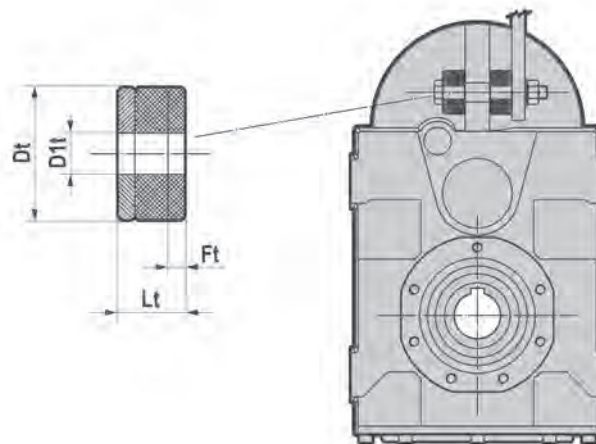

	<b>Dt</b>	<b>D1t</b>	<b>Lt</b>	<b>Ft</b>
<b>050</b>	40	12,5	20	~ 3
<b>060</b>	40	12,5	20	~ 3
<b>080</b>	40	12,5	20	~ 3
<b>100</b>	60	21	30	~ 5
<b>125</b>	60	21	30	~ 5

**Calettatore / Shrink disc / Frette d'accouplement /  
 Schrumpfscheibe / Aro de apriete / 锁紧盘**

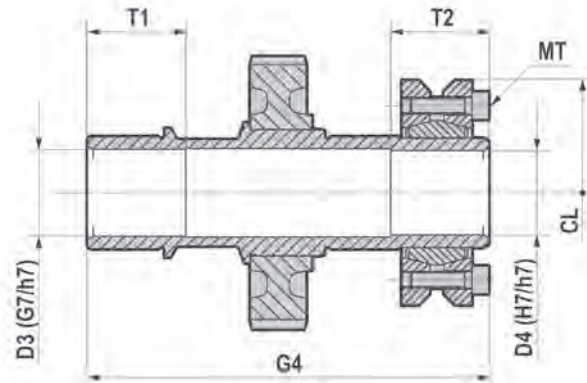
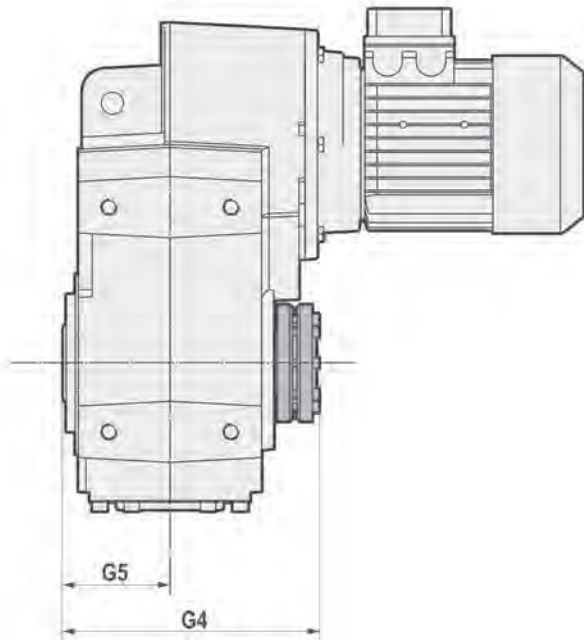

	<b>D3</b>	<b>D4</b>	<b>G4</b>	<b>G5</b>	<b>T1</b>	<b>T2</b>	<b>CL</b>	<b>MT 12.9 (Nm)</b>
<b>050</b>	31	30	152	60	35	35	74	15
<b>060</b>	36	35	173	70	40	35	80	15
<b>080</b>	41	40	217	90	50	40	100	15
<b>100</b>	51	50	248	105	55	40	115	15
<b>125</b>	61	60	282	120	60	50	145	40

- Pulire e sgrassare le zone degli alberi interessati all'accoppiamento. Rispettare la coppia di serraggio viti indicata (MT).
- Clean and degrease the surfaces of the shaft to be fitted to. Comply with the indicated tightening torque of screws (MT).
- Nettoyer et dégraisser les surfaces des arbres intéressés par l'accouplement. Respecter le couple de serrage des vis indiqué (MT).
- Vor Montage der Schrumpfscheibe den Außendurchmesser der Hohlwelle reinigen und entfetten. Die Schrauben (MT) mit dem vorgeschriebenen Drehmoment anziehen.
- Pulir y desengrasar las superficies de fijación. Respetar el par de apriete indicado para los tornillos (MT).
- 清洁待安装的轴并去除其表面油脂。螺杆拉紧转矩 (MT) 应与指定值一致。

