

INDUSTRY PROCESS
AND AUTOMATION SOLUTIONS



BONFIGLIOLI
RIDUTTORI

C



BONFIGLIOLI

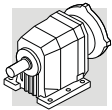

RIDUTTORE / GEAR UNIT
GETRIEBE / REDUCTEUR

C 31 2 F 52.4 S1 B5

OPZIONI / OPTIONS
OPTIONEN / OPTIONS



POSIZIONE DI MONTAGGIO / MOUNTING POSITION
EINBAULAGEN / POSITION DE MONTAGE

C...P: **B3** (Standard), B6, B7, B8, V5, V6

C...F/U/UF: **B5** (Standard), B51, B53, B52, V1, V3



DESIGNAZIONE INGRESSO / INPUT CONFIGURATION
BEZEICHNUNG DER ANTRIEBSSEITE / DESIGNATION ENTREE

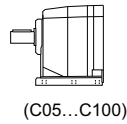

(C05...C100)

S0
S05
S1
S2
S3
S4
S5

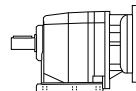
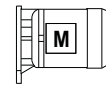

(C11...C100)

P63	P160
P71	P180
P80	P200
P90	P225
P100	P250
P112	P280
P132	

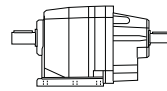
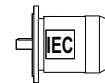

(C11...C100)

HS

RAPPORTO DI RIDUZIONE / GEAR RATIO
ÜBERSETZUNG / RAPPORT DE REDUCTION

FORMA COSTRUTTIVA / VERSION / BAUFORM / FORME DE CONSTRUCTION

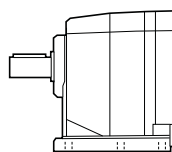

P
(C05...C100)

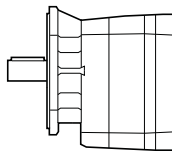

F
(C05...C31)
(C70...C100)

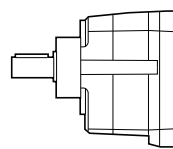

U
(C11...C61)

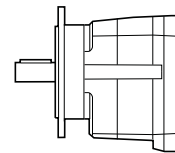

UFA
UFB
UFC
(C11...C61)

STADI DI RIDUZIONE / REDUCTIONS
GETRIEBESTUFEN / ETAGES DE REDUCTION

2, 3, 4

GRANDEZZA RIDUTTORE / GEAR FRAME SIZE / GETRIEBEBAUGRÖSSE / TAILLE REDUCTEUR

05, 11, 21, 31, 35, 41, 51, 61, 70, 80, 90, 100

TIPO RIDUTTORE: **C** = coassiale
GETRIEBETYP: **C** = Stirnradgetriebe

GEARBOX TYPE: **C** = helical in-line
TYPE DU REDUCTEUR: **C** = coaxial

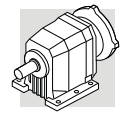

Designazione motore *Motor designation* Motor bezeichnung *Designation moteur*

MOTORE / MOTOR
MOTOR / MOTEUR

FRENO / BRAKE
BREMSE / FREIN

M 1LA 4 230/400-50 IP54 CLF W FD 7.5 R SB 220 SA

OPZIONI
OPTIONS
OPTIONEN
OPTIONS

22

ALIMENTAZ. FRENO
BRAKE SUPPLY
BREMSVERSORGUNG
ALIMENTATION FREIN

162 167 171

TIPO RADDRIZZATORE AC/DC
RECTIFIER TYPE
GLEICHRICHTERTYP
TYPE ALIMENTATEUR
NB, SB, NBR, SBR

163

LEVA DI SBLOCCO FRENO
BRAKE HAND RELEASE
BRESENTHANDLÜFTUNG
LEVIER DE DEBLOCAGE FREIN
R, RM

174

COPPIA FRENANTE / BRAKE TORQUE
BREMSMOMENT/ COUPLE FREIN

164 168 172

TIPO FRENO / BRAKE TYPE
BRESENTYP / TYPE DE FREIN

164 168 172

FD (freno c.c./ d.c. brake / G.S. Bremse / frein c.c.)
FA, BA (freno c.a./ a.c. brake / W.S. Bremse / frein c.a.)

POSIZIONE MORSETTIERA / TERMINAL BOX POSITION
KLEMMENKASTENLAGE / POSITION BOITE A BORNE
W (default), **N, E, S**

25

FORMA COSTRUTTIVA / MOTOR MOUNTING
BAUFORM / FORM DE CONSTRUCTION

— (motore integrato / compact motor
kompaktes Motor / moteur compact)

B5 (motore IEC / IEC - motor / IEC Motor / moteur CEI)

CLASSE ISOLAMENTO / INSULATION CLASS
ISOLIERUNGSKLASSE / CLASSE ISOLATION

CL F standard
CL H option

155

GRADO DI PROTEZIONE / DEGREE OF PROTECTION
SCHUTZART / DEGRE DE PROTECTION

IP55 standard (IP54 - motore autofrenante / brake motor / Bremssmotor / moteur frein)

149

TENSIONE - FREQUENZA / VOLTAGE - FREQUENCY
SPANNUNG - FREQUENZ / TENSION - FREQUENCE

153

NUMERO DI POLI / POLE NUMBER / POLZAHL / N.bre POLES
2, 4, 6, 2/4, 2/6, 2/8, 2/12, 4/6, 4/8

GRANDEZZA MOTORE / MOTOR SIZE / MOTOR-BAUGRÖSSE / TAILLE MOTEUR

0B - 5LA (motore integrato / compact motor / kompaktes Motor / moteur compact)
63A - 280M (motore IEC / IEC motor / IEC - motor / moteur CEI)

TIPO MOTORE/ MOTOR TYPE / MOTORTYP / TYPE MOTEUR

M = trifase integrato / compact 3-phase / kompaktes Dreiphasen / 3 phasé compact
BN = trifase IEC / IEC 3-phase / IEC Dreiphasen / 3 phasé CEI

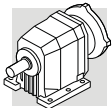

C 11



100 Nm

25 - DATI TECNICI
RIDUTTORI



25 - GEARBOX RATING
CHARTS

25 - GETRIEBE
AUSWAHLTABELLEN

25 - DONNEES TECHNIQUES
REDUCTEURS

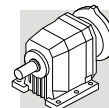
	i	$n_1 = 2800 \text{ min}^{-1}$					$n_1 = 1400 \text{ min}^{-1}$					
		n_2 min^{-1}	M_{n2} Nm	P_{n1} kW	R_{n1} N	R_{n2} N	n_2 min^{-1}	M_{n2} Nm	P_{n1} kW	R_{n1} N	R_{n2} N	
C 11 2_2.8	2.8	1011	30	3.3	750	600	505	37	2.1	990	790	113
C 11 2_3.7	3.7	767	34	2.9	720	610	384	42	1.8	960	800	
C 11 2_4.9	4.9	575	38	2.4	710	640	287	48	1.5	880	800	
C 11 2_6.2	6.2	449	42	2.1	650	660	225	53	1.3	810	830	
C 11 2_6.9	6.9	408	43	1.9	1120	1170	204	54	1.2	1300	1480	
C 11 2_7.6	7.6	367	45	1.8	1140	1220	184	56	1.1	1300	1540	
C 11 2_9.1	9.1	309	48	1.6	1120	1280	155	61	1.0	1300	1610	
C 11 2_10.1	10.1	278	49	1.5	1150	1340	139	63	0.97	1300	1680	
C 11 2_12.1	12.1	232	53	1.4	1120	1410	116	67	0.86	1300	1780	
C 11 2_13.4	13.4	209	55	1.3	1140	1460	104	70	0.81	1300	1840	
C 11 2_15.5	15.5	181	58	1.2	1100	1520	90	74	0.74	1300	1880	
C 11 2_17.2	17.2	163	60	1.1	1130	1590	82	76	0.68	1300	2000	
C 11 2_18.6	18.6	151	63	1.0	1090	1570	75	79	0.66	1300	1990	
C 11 2_20.6	20.6	136	65	0.97	1110	1670	68	82	0.61	1300	2000	
C 11 2_22.8	22.8	123	67	0.90	1080	1700	61	85	0.57	1300	2000	
C 11 2_25.4	25.4	110	69	0.84	1110	1800	55	88	0.54	1300	2000	
C 11 2_29.5	29.5	95	74	0.77	1060	1810	47	93	0.49	1300	2000	
C 11 2_32.8	32.8	85	75	0.71	1090	1970	43	90	0.42	1300	2000	
C 11 2_33.4	33.4	84	77	0.71	1030	1890	42	100	0.46	1286	2000	
C 11 2_37.0	37.0	76	79	0.66	1070	2000	38	90	0.38	1300	2000	
C 11 2_42.9	42.9	65	84	0.60	1010	2000	33	100	0.36	1300	2000	
C 11 2_47.6	47.6	59	85	0.55	1050	2000	29.4	90	0.29	1300	2000	
C 11 2_49.7	49.7	56	88	0.55	990	2000	28.2	100	0.31	1300	2000	
C 11 2_55.2	55.2	51	89	0.50	1030	2000	25.4	90	0.25	1300	2000	
C 11 2_59.6	59.6	47	78	0.40	1060	2000	23.5	82	0.21	1300	2000	
C 11 2_66.2	66.2	42	86	0.40	1060	2000	21.2	90	0.21	1300	2000	



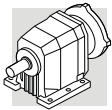

	i	$n_1 = 900 \text{ min}^{-1}$					$n_1 = 500 \text{ min}^{-1}$					
		n_2 min^{-1}	M_{n2} Nm	P_{n1} kW	R_{n1} N	R_{n2} N	n_2 min^{-1}	M_{n2} Nm	P_{n1} kW	R_{n1} N	R_{n2} N	
C 11 2_2.8	2.8	325	43	1.5	1140	910	187	53	1.1	1300	1080	113
C 11 2_3.7	3.7	247	49	1.3	1090	920	137	60	0.91	1300	1100	
C 11 2_4.9	4.9	185	55	1.1	1050	960	103	67	0.76	1280	1160	
C 11 2_6.2	6.2	144	61	0.97	960	980	80	70	0.62	1300	1390	
C 11 2_6.9	6.9	131	62	0.90	1300	1720	73	76	0.61	1300	2000	
C 11 2_7.6	7.6	118	65	0.85	1300	1780	66	79	0.57	1300	2000	
C 11 2_9.1	9.1	99	70	0.77	1300	1870	55	85	0.52	1300	2000	
C 11 2_10.1	10.1	89	72	0.71	1300	1950	50	88	0.48	1300	2000	
C 11 2_12.1	12.1	75	78	0.64	1300	2000	41	95	0.43	1300	2000	
C 11 2_13.4	13.4	67	81	0.60	1300	2000	37	90	0.37	1300	2000	
C 11 2_15.5	15.5	58	86	0.55	1300	2000	32	99	0.35	1300	2000	
C 11 2_17.2	17.2	52	88	0.51	1300	2000	29.1	90	0.29	1300	2000	
C 11 2_18.6	18.6	48	91	0.49	1300	2000	26.9	99	0.29	1300	2000	
C 11 2_20.6	20.6	44	89	0.43	1300	2000	24.2	89	0.24	1300	2000	
C 11 2_22.8	22.8	39	99	0.43	1300	2000	21.9	99	0.24	1300	2000	
C 11 2_25.4	25.4	35	89	0.35	1300	2000	19.7	89	0.19	1300	2000	
C 11 2_29.5	29.5	30	100	0.34	1300	2000	16.9	100	0.19	1300	2000	
C 11 2_32.8	32.8	27.5	90	0.27	1300	2000	15.3	90	0.15	1300	2000	
C 11 2_33.4	33.4	27.0	100	0.30	1300	2000	15.0	100	0.17	1300	2000	
C 11 2_37.0	37.0	24.3	90	0.24	1300	2000	13.5	90	0.13	1300	2000	
C 11 2_42.9	42.9	21.0	100	0.23	1300	2000	11.7	100	0.13	1300	2000	
C 11 2_47.6	47.6	18.9	90	0.19	1300	2000	10.5	90	0.10	1300	2000	
C 11 2_49.7	49.7	18.1	100	0.20	1300	2000	10.1	100	0.11	1300	2000	
C 11 2_55.2	55.2	16.3	90	0.16	1300	2000	9.1	90	0.09	1300	2000	
C 11 2_59.6	59.6	15.1	85	0.14	1300	2000	8.4	88	0.08	1300	2000	
C 11 2_66.2	66.2	13.6	90	0.13	1300	2000	7.6	90	0.07	1300	2000	





C 21

200 Nm

	i	$n_1 = 2800 \text{ min}^{-1}$					$n_1 = 1400 \text{ min}^{-1}$					
		n_2 min^{-1}	M_{n2} Nm	P_{n1} kW	R_{n1} N	R_{n2} N	n_2 min^{-1}	M_{n2} Nm	P_{n1} kW	R_{n1} N	R_{n2} N	
C 21 2_2.7	2.7	1029	65	7.4	—	1150	515	80	4.5	—	1460	116
C 21 2_3.7	3.7	755	70	5.8	—	1290	377	90	3.7	—	1610	
C 21 2_4.8	4.8	587	80	5.2	—	1370	294	100	3.2	—	1730	
C 21 2_6.1	6.1	460	85	4.3	—	1500	230	105	2.7	—	1900	
C 21 2_6.4	6.4	439	100	4.8	960	1510	219	125	3.0	1230	1910	
C 21 2_7.1	7.1	395	105	4.6	1090	1570	198	130	2.8	1420	1990	
C 21 2_8.7	8.7	323	110	3.9	1030	1680	161	140	2.5	1260	2110	
C 21 2_9.6	9.6	290	115	3.7	1160	1750	145	145	2.3	1460	2200	
C 21 2_11.2	11.2	251	125	3.5	930	1790	125	155	2.1	1220	2280	
C 21 2_12.4	12.4	226	125	3.1	1160	1900	113	160	2.0	1420	2380	
C 21 2_14.3	14.3	196	135	2.9	870	1950	98	170	1.8	1100	2460	
C 21 2_15.8	15.8	177	140	2.7	1030	2030	88	175	1.7	1320	2570	
C 21 2_18.0	18.0	155	145	2.5	840	2120	78	185	1.6	1010	2650	
C 21 2_20.0	20.0	140	150	2.3	1000	2210	70	190	1.5	1250	2770	
C 21 2_21.9	21.9	128	155	2.2	800	2250	64	200	1.4	940	2810	
C 21 2_24.3	24.3	115	160	2.0	980	2350	58	200	1.3	1250	2970	
C 21 2_26.7	26.7	105	170	2.0	660	2380	52	200	1.2	1040	3090	
C 21 2_29.6	29.6	95	175	1.8	850	2490	47	200	1.0	1350	3270	
C 21 2_33.1	33.1	85	180	1.7	550	2570	42	200	0.93	1100	3420	
C 21 2_36.8	36.8	76	185	1.6	750	2690	38	200	0.84	1400	3610	
C 21 2_39.0	39.0	72	165	1.3	860	2880	36	170	0.67	1630	3880	
C 21 2_43.3	43.3	65	185	1.3	830	2910	32	190	0.68	1610	3950	
C 21 2_49.3	49.3	57	135	0.85	1320	3410	28.4	140	0.44	1770	4490	
C 21 2_54.7	54.7	51	150	0.85	1320	3470	25.6	155	0.44	1770	4600	
C 21 2_57.0	57.0	49	110	0.60	1410	3780	24.6	115	0.31	1830	4920	
C 21 2_63.3	63.3	44	125	0.61	1400	3860	22.1	130	0.32	1820	5000	
C 21 3_58.8	58.8	48	180	0.96	880	3390	23.8	190	0.24	1240	4510	
C 21 3_65.3	65.3	43	200	0.97	880	3440	21.4	200	0.48	1270	4670	
C 21 3_74.4	74.4	38	200	0.85	960	3630	18.8	200	0.42	1300	4920	
C 21 3_82.6	82.6	34	200	0.76	1010	3820	16.9	200	0.38	1300	5000	
C 21 3_90.2	90.2	31	200	0.70	1050	3960	15.5	200	0.35	1300	5000	
C 21 3_100.2	100.2	28.0	200	0.63	1090	4160	14.0	200	0.31	1300	5000	
C 21 3_110.0	110.0	25.5	200	0.57	1130	4320	12.7	200	0.29	1300	5000	
C 21 3_122.2	122.2	22.9	200	0.52	1160	4540	11.5	200	0.26	1300	5000	
C 21 3_136.5	136.6	20.5	200	0.46	1190	4740	10.3	200	0.23	1300	5000	
C 21 3_151.7	151.7	18.5	200	0.42	1220	4980	9.2	200	0.21	1300	5000	
C 21 3_160.7	160.7	17.4	195	0.38	1240	5000	8.7	200	0.20	1300	5000	
C 21 3_178.5	178.5	15.7	200	0.35	1260	5000	7.8	200	0.18	1300	5000	
C 21 3_203.2	203.2	13.8	160	0.25	1300	5000	6.9	165	0.13	1300	5000	
C 21 3_225.8	225.8	12.4	180	0.25	1300	5000	6.2	185	0.13	1300	5000	
C 21 3_235.0	235.0	11.9	130	0.17	1300	5000	6.0	140	0.09	1300	5000	
C 21 3_261.0	261.0	10.7	145	0.18	1300	5000	5.4	155	0.09	1300	5000	

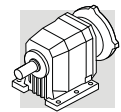

(-) Interpellare il ns. servizio tecnico comunicando i dati relativi al carico radiale (senso di rotazione, orientamento, posizione)
 (-) Contact our technical service department advising radial load data (rotation direction, orientation, position)
 (-) Nehmen Sie bitte Kontakt mit unserem Applikationsdienst und Querkraftsdaten angeben (Drehrichtung, Orientierung, Anordnung)
 (-) Consulter notre service technique en donnant les détails concernant la charge radiale (sens de rotation, indexage, position)



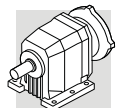

	i	$n_1 = 900 \text{ min}^{-1}$					$n_1 = 500 \text{ min}^{-1}$					
		n_2 min^{-1}	M_{n2} Nm	P_{n1} kW	R_{n1} N	R_{n2} N	n_2 min^{-1}	M_{n2} Nm	P_{n1} kW	R_{n1} N	R_{n2} N	
C 21 2_2.7	2.7	331	95	3.5	—	1670	184	100	2.0	400	2150	116
C 21 2_3.7	3.7	243	105	2.8	—	1850	135	105	1.6	800	2430	
C 21 2_4.8	4.8	189	105	2.2	170	2090	105	105	1.2	1200	2710	
C 21 2_6.1	6.1	148	110	1.8	200	2290	82	116	1.0	980	2930	
C 21 2_6.4	6.4	141	145	2.3	1420	2220	78	175	1.5	1760	2700	
C 21 2_7.1	7.1	127	150	2.1	1650	2310	71	180	1.4	2060	2820	
C 21 2_8.7	8.7	104	165	1.9	1410	2430	58	200	1.3	1730	2960	
C 21 2_9.6	9.6	93	170	1.7	1650	2530	52	200	1.1	2130	3130	
C 21 2_11.2	11.2	81	180	1.6	1400	2640	45	200	0.99	2060	3330	
C 21 2_12.4	12.4	73	185	1.5	1650	2760	40	200	0.89	2200	3520	
C 21 2_14.3	14.3	63	195	1.4	1310	2860	35	200	0.77	2200	3730	
C 21 2_15.8	15.8	57	200	1.3	1580	2990	32	200	0.70	2200	3920	
C 21 2_18.0	18.0	50	200	1.1	1420	3170	27.7	200	0.61	2200	4140	
C 21 2_20.0	20.0	45	200	0.99	1750	3340	25.0	200	0.55	2200	4350	
C 21 2_21.9	21.9	41	200	0.91	1590	3460	22.9	200	0.50	2200	4500	
C 21 2_24.3	24.3	37	200	0.82	1900	3650	20.6	200	0.45	2200	4720	
C 21 2_26.7	26.7	34	200	0.74	1700	3790	18.7	200	0.41	2200	4900	
C 21 2_29.6	29.6	30	200	0.67	1980	3990	16.9	200	0.37	2200	5000	
C 21 2_33.1	33.1	27.2	200	0.60	1750	4170	15.1	200	0.33	2200	5000	
C 21 2_36.8	36.8	24.5	200	0.54	1990	4390	13.6	200	0.30	2200	5000	
C 21 2_39.0	39.0	23.1	170	0.43	2020	4680	12.8	170	0.24	2200	5000	
C 21 2_43.3	43.3	20.8	190	0.44	2020	4770	11.6	190	0.24	2200	5000	
C 21 2_49.3	49.3	18.3	145	0.29	2080	5000	10.1	155	0.17	2200	5000	
C 21 2_54.7	54.7	16.4	160	0.29	2090	5000	9.1	170	0.17	2200	5000	
C 21 2_57.0	57.0	15.8	120	0.21	2140	5000	8.8	125	0.12	2200	5000	
C 21 2_63.3	63.3	14.2	135	0.21	2140	5000	7.9	140	0.12	2200	5000	
C 21 3_58.8	58.8	15.3	200	0.34	1300	5000	8.5	200	0.19	1300	5000	
C 21 3_65.3	65.3	13.8	200	0.31	1300	5000	7.7	200	0.17	1300	5000	
C 21 3_74.4	74.4	12.1	200	0.27	1300	5000	6.7	200	0.15	1300	5000	
C 21 3_82.6	82.6	10.9	200	0.25	1300	5000	6.1	200	0.14	1300	5000	
C 21 3_90.2	90.2	10.0	200	0.22	1300	5000	5.5	200	0.12	1300	5000	
C 21 3_100.2	100.2	9.0	200	0.20	1300	5000	5.0	200	0.11	1300	5000	
C 21 3_110.0	110.0	8.2	200	0.18	1300	5000	4.5	200	0.10	1300	5000	
C 21 3_122.2	122.2	7.4	200	0.17	1300	5000	4.1	200	0.09	1300	5000	
C 21 3_136.5	136.6	6.6	200	0.15	1300	5000	3.7	200	0.08	1300	5000	
C 21 3_151.7	151.7	5.9	200	0.13	1300	5000	3.3	200	0.07	1300	5000	
C 21 3_160.7	160.7	5.6	200	0.13	1300	5000	3.1	200	0.07	1300	5000	
C 21 3_178.5	178.5	5.0	200	0.11	1300	5000	2.8	200	0.06	1300	5000	
C 21 3_203.2	203.2	4.4	170	0.08	1300	5000	2.5	180	0.05	1300	5000	
C 21 3_225.8	225.8	4.0	195	0.09	1300	5000	2.2	200	0.05	1300	5000	
C 21 3_235.0	235.0	3.8	140	0.06	1300	5000	2.1	150	0.04	1300	5000	
C 21 3_261.0	261.0	3.4	160	0.06	1300	5000	1.9	165	0.04	1300	5000	

(-) Interpellare il ns. servizio tecnico comunicando i dati relativi al carico radiale (senso di rotazione, orientamento, posizione)
 (-) Contact our technical service department advising radial load data (rotation direction, orientation, position)
 (-) Nehmen Sie bitte Kontakt mit unserem Applikationsdienst und Querkraftsdaten angeben (Drehrichtung, Orientierung, Anordnung)
 (-) Consulter notre service technique en donnant les détails concernant la charge radiale (sens de rotation, indexage, position)

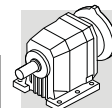

	i	$n_1 = 2800 \text{ min}^{-1}$					$n_1 = 1400 \text{ min}^{-1}$					
		n_2 min^{-1}	M_{n2} Nm	P_{n1} kW	R_{n1} N	R_{n2} N	n_2 min^{-1}	M_{n2} Nm	P_{n1} kW	R_{n1} N	R_{n2} N	
C 31 2_2.9	2.9	972	105	11.3	670	1710	486	130	7.0	940	2170	119
C 31 2_3.7	3.7	749	120	9.9	560	1830	374	150	6.2	750	2310	
C 31 2_5.0	5.0	566	135	8.4	470	1990	283	155	4.8	1100	2600	
C 31 2_6.3	6.3	447	150	7.4	300	2130	224	155	3.8	1450	2890	
C 31 2_6.5	6.5	434	155	7.4	1860	2270	217	195	4.7	2200	2870	
C 31 2_7.2	7.2	391	160	6.9	1890	2370	196	200	4.3	2200	2990	
C 31 2_8.4	8.4	335	170	6.3	1870	2480	167	215	4.0	2200	3110	
C 31 2_9.3	9.3	301	175	5.8	1910	2580	151	220	3.7	2200	3260	
C 31 2_11.1	11.1	252	190	5.3	1880	2700	126	240	3.3	2200	3400	
C 31 2_12.3	12.3	227	195	4.9	1910	2820	114	245	3.1	2200	3560	
C 31 2_14.0	14.0	199	205	4.5	1880	2930	100	260	2.9	2200	3680	
C 31 2_15.6	15.6	180	215	4.3	1900	3030	90	270	2.7	2200	3820	
C 31 2_18.1	18.1	155	225	3.8	1870	3170	77	285	2.4	2200	3990	
C 31 2_20.1	20.1	139	235	3.6	1900	3290	70	295	2.3	2200	4160	
C 31 2_22.6	22.6	124	245	3.3	1850	3410	62	300	2.0	2200	4330	
C 31 2_25.1	25.1	111	250	3.1	1890	3560	56	300	1.8	2200	4570	
C 31 2_26.8	26.8	105	260	3.0	1840	3600	52	300	1.7	2200	4680	
C 31 2_29.8	29.8	94	265	2.7	1880	3770	47	300	1.6	2200	4920	
C 31 2_32.5	32.5	86	275	2.6	1760	3850	43	300	1.4	2200	5090	
C 31 2_36.1	36.1	78	280	2.4	1870	4030	39	300	1.3	2200	5350	
C 31 2_40.7	40.7	69	295	2.2	1620	4160	34	300	1.1	2200	5500	
C 31 2_45.3	45.3	62	300	2.0	1860	4360	31	300	1.0	2200	5500	
C 31 2_47.2	47.2	59	300	2.0	1610	4420	29.7	300	0.98	2200	5500	
C 31 2_52.4	52.4	53	300	1.8	1860	4650	26.7	300	0.88	2200	5500	
C 31 2_60.2	60.2	47	180	0.92	2030	5500	23.3	190	0.49	2200	5500	
C 31 2_66.8	66.8	42	205	0.95	2020	5500	21.0	215	0.50	2200	5500	
C 31 3_74.3	74.3	38	275	1.2	790	5500	18.8	300	0.64	1170	5500	
C 31 3_82.6	82.6	34	300	1.1	820	5500	17.0	300	0.57	1240	5500	
C 31 3_93.0	93.0	30	290	0.98	940	5500	15.1	300	0.51	1300	5500	
C 31 3_103.3	103.3	27.1	300	0.92	980	5500	13.6	300	0.46	1300	5500	
C 31 3_110.2	110.2	25.4	300	0.86	1010	5500	12.7	300	0.43	1300	5500	
C 31 3_122.4	122.4	22.9	300	0.77	1060	5500	11.4	300	0.39	1300	5500	
C 31 3_133.6	133.6	21.0	300	0.71	1090	5500	10.5	300	0.35	1300	5500	
C 31 3_148.4	148.4	18.9	300	0.64	1130	5500	9.4	300	0.32	1300	5500	
C 31 3_167.5	167.5	16.7	300	0.56	1170	5500	8.4	300	0.28	1300	5500	
C 31 3_186.0	186.0	15.1	300	0.51	1200	5500	7.5	300	0.25	1300	5500	
C 31 3_194.1	194.1	14.4	280	0.45	1230	5500	7.2	295	0.24	1300	5500	
C 31 3_215.6	215.6	13.0	300	0.44	1240	5500	6.5	300	0.22	1300	5500	
C 31 3_247.3	247.3	11.3	215	0.27	1300	5500	5.7	225	0.14	1300	5500	
C 31 3_274.7	274.7	10.2	240	0.28	1300	5500	5.1	255	0.15	1300	5500	



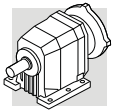

	i	$n_1 = 900 \text{ min}^{-1}$					$n_1 = 500 \text{ min}^{-1}$					
		n_2 min^{-1}	M_{n2} Nm	P_{n1} kW	R_{n1} N	R_{n2} N	n_2 min^{-1}	M_{n2} Nm	P_{n1} kW	R_{n1} N	R_{n2} N	
C 31 2_2.9	2.9	313	150	5.2	1120	2510	174	155	3.0	2200	3220	119
C 31 2_3.7	3.7	241	155	4.1	1570	2790	134	175	2.6	2200	3480	
C 31 2_5.0	5.0	182	162	3.2	1870	3120	101	198	2.2	2200	3790	
C 31 2_6.3	6.3	144	178	2.8	1730	3350	80	200	1.8	2200	4180	
C 31 2_6.5	6.5	140	225	3.5	2200	3330	78	275	2.3	2200	4040	
C 31 2_7.2	7.2	126	235	3.3	2200	3450	70	285	2.2	2200	4200	
C 31 2_8.4	8.4	108	250	3.0	2200	3600	60	300	2.0	2200	4410	
C 31 2_9.3	9.3	97	260	2.8	2200	3750	54	300	1.8	2200	4640	
C 31 2_11.1	11.1	81	280	2.5	2200	3930	45	300	1.5	2200	4990	
C 31 2_12.3	12.3	73	285	2.3	2200	4120	41	300	1.3	2200	5250	
C 31 2_14.0	14.0	64	300	2.1	2200	4270	36	300	1.2	2200	5500	
C 31 2_15.6	15.6	58	300	1.9	2200	4500	32	300	1.1	2200	5500	
C 31 2_18.1	18.1	50	300	1.6	2200	4780	27.7	300	0.91	2200	5500	
C 31 2_20.1	20.1	45	300	1.5	2200	5030	24.9	300	0.82	2200	5500	
C 31 2_22.6	22.6	40	300	1.3	2200	5270	22.1	300	0.73	2200	5500	
C 31 2_25.1	25.1	36	300	1.2	2200	5500	19.9	300	0.66	2200	5500	
C 31 2_26.8	26.8	34	300	1.1	2200	5500	18.7	300	0.62	2200	5500	
C 31 2_29.8	29.8	30	300	1.0	2200	5500	16.8	300	0.56	2200	5500	
C 31 2_32.5	32.5	27.7	300	0.92	2200	5500	15.4	300	0.51	2200	5500	
C 31 2_36.1	36.1	24.9	300	0.82	2200	5500	13.9	300	0.46	2200	5500	
C 31 2_40.7	40.7	22.1	300	0.73	2200	5500	12.3	300	0.41	2200	5500	
C 31 2_45.3	45.3	19.9	300	0.66	2200	5500	11.0	300	0.37	2200	5500	
C 31 2_47.2	47.2	19.1	300	0.63	2200	5500	10.6	300	0.35	2200	5500	
C 31 2_52.4	52.4	17.2	300	0.57	2200	5500	9.5	300	0.32	2200	5500	
C 31 2_60.2	60.2	15.0	200	0.33	2200	5500	8.3	205	0.19	2200	5500	
C 31 2_66.8	66.8	13.5	220	0.33	2200	5500	7.5	230	0.19	2200	5500	
C 31 3_74.3	74.3	12.1	300	0.41	1300	5500	6.7	300	0.23	1300	5500	
C 31 3_82.6	82.6	10.9	300	0.37	1300	5500	6.1	300	0.20	1300	5500	
C 31 3_93.0	93.0	9.7	300	0.33	1300	5500	5.4	300	0.18	1300	5500	
C 31 3_103.3	103.3	8.7	300	0.29	1300	5500	4.8	300	0.16	1300	5500	
C 31 3_110.2	110.2	8.2	300	0.28	1300	5500	4.5	300	0.15	1300	5500	
C 31 3_122.4	122.4	7.4	300	0.25	1300	5500	4.1	300	0.14	1300	5500	
C 31 3_133.6	133.6	6.7	300	0.23	1300	5500	3.7	300	0.13	1300	5500	
C 31 3_148.4	148.4	6.1	300	0.20	1300	5500	3.4	300	0.11	1300	5500	
C 31 3_167.5	167.5	5.4	300	0.18	1300	5500	3.0	300	0.10	1300	5500	
C 31 3_186.0	186.0	4.8	300	0.16	1300	5500	2.7	300	0.09	1300	5500	
C 31 3_194.1	194.1	4.6	300	0.16	1300	5500	2.6	300	0.09	1300	5500	
C 31 3_215.6	215.6	4.2	300	0.14	1300	5500	2.3	300	0.08	1300	5500	
C 31 3_247.3	247.3	3.6	235	0.10	1300	5500	2.0	245	0.06	1300	5500	
C 31 3_274.7	274.7	3.3	260	0.10	1300	5500	1.8	275	0.06	1300	5500	





C 35

450 Nm

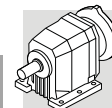
	i	$n_1 = 2800 \text{ min}^{-1}$					$n_1 = 1400 \text{ min}^{-1}$					
		n_2 min^{-1}	M_{n2} Nm	P_{n1} kW	R_{n1} N	R_{n2} N	n_2 min^{-1}	M_{n2} Nm	P_{n1} kW	R_{n1} N	R_{n2} N	
C 35 2_2.7	2.7	1037	140	16.0	670	1750	519	170	9.7	1150	2240	122
C 35 2_3.5	3.5	800	150	13.2	910	1920	400	185	8.2	1320	2440	
C 35 2_4.6	4.6	609	165	11.1	920	2110	304	200	6.7	1470	2700	
C 35 2_5.8	5.8	483	170	9.0	1160	2330	241	200	5.3	1990	3020	
C 35 2_6.1	6.1	459	275	13.9	1580	2040	230	345	8.7	2020	2570	
C 35 2_6.8	6.8	412	285	12.9	1750	2130	206	355	8.1	2220	2710	
C 35 2_7.9	7.9	354	305	11.9	1590	2200	177	380	7.4	2090	2790	
C 35 2_8.8	8.8	318	310	10.9	1780	2330	159	380	6.7	2270	3000	
C 35 2_10.5	10.5	267	335	9.8	1610	2410	133	380	5.6	2270	3250	
C 35 2_11.7	11.7	239	340	9.0	1790	2560	120	380	5.0	2370	3460	
C 35 2_13.3	13.3	211	355	8.2	1660	2650	105	380	4.4	2340	3660	
C 35 2_14.8	14.8	189	360	7.5	1800	2810	95	380	4.0	2440	3890	
C 35 2_17.1	17.1	164	380	6.9	1640	2910	82	380	3.4	2410	4150	
C 35 2_19.0	19.0	147	380	6.2	1820	3110	74	380	3.1	2500	4400	
C 35 3_20.2	20.2	139	315	4.9	2300	3500	69	395	3.1	2900	4420	
C 35 3_22.1	22.1	127	340	4.9	2300	3570	63	430	3.1	2900	4490	
C 35 3_26.2	26.2	107	355	4.3	2300	3760	53	450	2.7	2890	4730	
C 35 3_28.7	28.7	98	385	4.2	2300	3820	49	450	2.5	2930	4980	
C 35 3_34.7	34.7	81	395	3.6	2300	4110	40	450	2.0	2930	5410	
C 35 3_38.1	38.1	73	435	3.6	2300	4140	37	450	1.9	2970	5690	
C 35 3_43.9	43.9	64	430	3.1	2300	4430	32	450	1.6	2960	6030	
C 35 3_48.2	48.2	58	450	2.9	2310	4580	29.0	450	1.5	2990	6330	
C 35 3_56.5	56.5	50	450	2.5	2300	4910	24.8	450	1.3	2990	6500	
C 35 3_62.0	62.0	45	450	2.3	2330	5170	22.6	450	1.1	3000	6500	
C 35 3_70.7	70.7	40	450	2.0	2320	5460	19.8	450	1.0	3000	6500	
C 35 3_77.6	77.6	36	450	1.8	2350	5740	18.0	450	0.91	3000	6500	
C 35 3_83.8	83.8	33	450	1.7	2330	5910	16.7	450	0.85	3000	6500	
C 35 3_91.9	91.9	30	450	1.5	2360	6200	15.2	450	0.77	3000	6500	
C 35 3_101.6	101.6	27.6	450	1.4	2340	6450	13.8	450	0.70	3000	6500	
C 35 3_111.5	111.5	25.1	450	1.3	2360	6500	12.6	450	0.64	3000	6500	
C 35 3_127.3	127.3	22.0	450	1.1	2350	6500	11.0	450	0.56	3000	6500	
C 35 3_139.8	139.8	20.0	450	1.0	2370	6500	10.0	450	0.51	3000	6500	
C 35 3_147.6	147.6	19.0	450	0.96	2350	6500	9.5	450	0.48	3000	6500	
C 35 3_162.0	162.0	17.3	450	0.88	2380	6500	8.6	450	0.44	3000	6500	
C 35 3_188.0	188.0	14.9	450	0.75	2360	6500	7.4	450	0.38	3000	6500	
C 35 3_206.4	206.4	13.6	450	0.69	2380	6500	6.8	450	0.34	3000	6500	
C 35 4_232.3	232.3	12.1	450	0.62	1170	6500	6.0	450	0.31	1300	6500	
C 35 4_255.0	255.0	11.0	450	0.57	1190	6500	5.5	450	0.28	1300	6500	
C 35 4_290.6	290.6	9.6	450	0.50	1220	6500	4.8	450	0.25	1300	6500	
C 35 4_318.9	318.9	8.8	450	0.45	1230	6500	4.4	450	0.23	1300	6500	
C 35 4_344.3	344.3	8.1	450	0.42	1240	6500	4.1	450	0.21	1300	6500	
C 35 4_377.9	377.9	7.4	450	0.38	1260	6500	3.7	450	0.19	1300	6500	
C 35 4_417.6	417.6	6.7	450	0.35	1270	6500	3.4	450	0.17	1300	6500	
C 35 4_458.4	458.4	6.1	450	0.32	1280	6500	3.1	450	0.16	1300	6500	
C 35 4_523.5	523.5	5.3	450	0.28	1290	6500	2.7	450	0.14	1300	6500	
C 35 4_574.7	574.7	4.9	450	0.25	1300	6500	2.4	450	0.13	1300	6500	
C 35 4_606.6	606.6	4.6	450	0.24	1300	6500	2.3	450	0.12	1300	6500	
C 35 4_665.9	665.9	4.2	450	0.22	1300	6500	2.1	450	0.11	1300	6500	
C 35 4_773.0	773.0	3.6	450	0.19	1300	6500	1.8	450	0.09	1300	6500	
C 35 4_848.5	848.5	3.3	450	0.17	1300	6500	1.6	450	0.09	1300	6500	



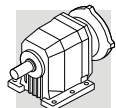

	i	$n_1 = 900 \text{ min}^{-1}$					$n_1 = 500 \text{ min}^{-1}$					
		n_2 min^{-1}	M_{n2} Nm	P_{n1} kW	R_{n1} N	R_{n2} N	n_2 min^{-1}	M_{n2} Nm	P_{n1} kW	R_{n1} N	R_{n2} N	
C 35 2_2.7	2.7	333	190	7.0	1670	2640	185	200	4.1	3000	3390	122
C 35 2_3.5	3.5	257	200	5.7	2160	2920	143	200	3.1	3000	3810	
C 35 2_4.6	4.6	196	200	4.3	2590	3320	109	200	2.4	3000	4300	
C 35 2_5.8	5.8	155	200	3.4	2680	3690	86	200	1.9	3000	4740	
C 35 2_6.1	6.1	148	380	6.2	2530	3080	82	380	3.4	3000	4150	
C 35 2_6.8	6.8	132	380	5.5	2660	3290	74	380	3.1	3000	4400	
C 35 2_7.9	7.9	114	380	4.8	2680	3530	63	380	2.7	3000	4690	
C 35 2_8.8	8.8	102	380	4.3	2790	3750	57	380	2.4	3000	4960	
C 35 2_10.5	10.5	86	380	3.6	2790	4060	48	380	2.0	3000	5340	
C 35 2_11.7	11.7	77	380	3.2	2900	4300	43	380	1.8	3000	5630	
C 35 2_13.3	13.3	68	380	2.8	2870	4540	38	380	1.6	3000	5930	
C 35 2_14.8	14.8	61	380	2.5	2970	4800	34	380	1.4	3000	6240	
C 35 2_17.1	17.1	53	380	2.2	2940	5110	29.2	380	1.2	3000	6500	
C 35 2_19.0	19.0	47	380	2.0	3000	5390	26.3	380	1.1	3000	6500	
C 35 3_20.2	20.2	45	450	2.3	3000	5160	24.8	450	1.3	3000	6500	
C 35 3_22.1	22.1	41	450	2.1	3000	5430	22.6	450	1.1	3000	6500	
C 35 3_26.2	26.2	34	450	1.7	3000	5830	19.1	450	0.97	3000	6500	
C 35 3_28.7	28.7	31	450	1.6	3000	6120	17.4	450	0.88	3000	6500	
C 35 3_34.7	34.7	25.9	450	1.3	3000	6500	14.4	450	0.73	3000	6500	
C 35 3_38.1	38.1	23.6	450	1.2	3000	6500	13.1	450	0.66	3000	6500	
C 35 3_43.9	43.9	20.5	450	1.0	3000	6500	11.4	450	0.58	3000	6500	
C 35 3_48.2	48.2	18.7	450	0.95	3000	6500	10.4	450	0.53	3000	6500	
C 35 3_56.5	56.5	15.9	450	0.81	3000	6500	8.8	450	0.45	3000	6500	
C 35 3_62.0	62.0	14.5	450	0.74	3000	6500	8.1	450	0.41	3000	6500	
C 35 3_70.7	70.7	12.7	450	0.64	3000	6500	7.1	450	0.36	3000	6500	
C 35 3_77.6	77.6	11.6	450	0.59	3000	6500	6.4	450	0.33	3000	6500	
C 35 3_83.8	83.8	10.7	450	0.54	3000	6500	6.0	450	0.30	3000	6500	
C 35 3_91.9	91.9	9.8	450	0.50	3000	6500	5.4	450	0.28	3000	6500	
C 35 3_101.6	101.6	8.9	450	0.45	3000	6500	4.9	450	0.25	3000	6500	
C 35 3_111.5	111.5	8.1	450	0.41	3000	6500	4.5	450	0.23	3000	6500	
C 35 3_127.3	127.3	7.1	450	0.36	3000	6500	3.9	450	0.20	3000	6500	
C 35 3_139.8	139.8	6.4	450	0.33	3000	6500	3.6	450	0.18	3000	6500	
C 35 3_147.6	147.6	6.1	450	0.31	3000	6500	3.4	450	0.17	3000	6500	
C 35 3_162.0	162.0	5.6	450	0.28	3000	6500	3.1	450	0.16	3000	6500	
C 35 3_188.0	188.0	4.8	450	0.24	3000	6500	2.7	450	0.13	3000	6500	
C 35 3_206.4	206.4	4.4	450	0.22	3000	6500	2.4	450	0.12	3000	6500	
C 35 4_232.3	232.3	3.9	450	0.20	1300	6500	2.2	450	0.11	1300	6500	
C 35 4_255.0	255.0	3.5	450	0.18	1300	6500	2.0	450	0.10	1300	6500	
C 35 4_290.6	290.6	3.1	450	0.16	1300	6500	1.7	450	0.09	1300	6500	
C 35 4_318.9	318.9	2.8	450	0.15	1300	6500	1.6	450	0.08	1300	6500	
C 35 4_344.3	344.3	2.6	450	0.14	1300	6500	1.5	450	0.08	1300	6500	
C 35 4_377.9	377.9	2.4	450	0.12	1300	6500	1.3	450	0.07	1300	6500	
C 35 4_417.6	417.6	2.2	450	0.11	1300	6500	1.2	450	0.06	1300	6500	
C 35 4_458.4	458.4	2.0	450	0.10	1300	6500	1.1	450	0.06	1300	6500	
C 35 4_523.5	523.5	1.7	450	0.09	1300	6500	1.0	450	0.05	1300	6500	
C 35 4_574.7	574.7	1.6	450	0.08	1300	6500	0.87	450	0.05	1300	6500	
C 35 4_606.6	606.6	1.5	450	0.08	1300	6500	0.82	450	0.04	1300	6500	
C 35 4_665.9	665.9	1.4	450	0.07	1300	6500	0.75	450	0.04	1300	6500	
C 35 4_773.0	773.0	1.2	450	0.06	1300	6500	0.65	450	0.03	1300	6500	
C 35 4_848.5	848.5	1.1	450	0.05	1300	6500	0.59	450	0.03	1300	6500	



C 41

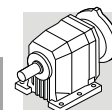

600 Nm

	i	$n_1 = 2800 \text{ min}^{-1}$					$n_1 = 1400 \text{ min}^{-1}$					
		n_2 min^{-1}	M_{n2} Nm	P_{n1} kW	R_{n1} N	R_{n2} N	n_2 min^{-1}	M_{n2} Nm	P_{n1} kW	R_{n1} N	R_{n2} N	
C 41 2_2.7	2.7	1037	245	28	980	1290	519	245	14.0	1390	2060	125
C 41 2_3.6	3.6	778	255	22	1070	1540	389	255	10.9	1650	2390	
C 41 2_4.7	4.7	596	260	17.1	1170	1800	298	260	8.5	2010	2730	
C 41 2_6.0	6.0	467	260	13.4	1290	2100	233	260	6.7	2400	3110	
C 41 2_6.4	6.4	438	275	13.3	2270	2590	219	345	8.3	2860	3260	
C 41 2_7.1	7.1	394	285	12.4	2360	2700	197	355	7.7	2980	3420	
C 41 2_8.6	8.6	326	305	10.9	2300	2860	163	385	6.9	2900	3600	
C 41 2_9.6	9.6	292	310	10.0	2410	3010	146	390	6.3	3030	3800	
C 41 2_11.2	11.2	250	335	9.2	2310	3100	125	420	5.8	2910	3920	
C 41 2_12.4	12.4	226	340	8.5	2440	3270	113	425	5.3	3070	4140	
C 41 2_14.2	14.2	197	355	7.7	2330	3410	99	445	4.8	2980	4300	
C 41 2_15.8	15.8	177	360	7.0	2460	3590	89	450	4.4	3120	4540	
C 41 2_17.8	17.8	157	380	6.6	2330	3680	79	480	4.2	3050	4630	
C 41 2_19.8	19.8	141	385	6.0	2460	3880	71	485	3.8	3180	4890	
C 41 2_22.6	22.6	124	410	5.6	2320	3990	62	500	3.4	3110	5110	
C 41 2_25.0	25.0	112	415	5.1	2460	4210	56	500	3.1	3230	5420	
C 41 2_28.3	28.3	99	445	4.9	2310	4290	49	500	2.7	3180	5710	
C 41 2_31.4	31.4	89	445	4.4	2440	4550	45	500	2.5	3300	6040	
C 41 2_33.4	33.4	84	465	4.3	2390	4560	42	500	2.3	3220	6170	
C 41 2_37.1	37.1	75	470	3.9	2440	4810	38	500	2.1	3320	6520	
C 41 2_44.8	44.8	63	500	3.4	2660	5130	31	500	1.7	3500	7000	
C 41 3_28.5	28.5	98	445	4.9	3060	4300	49	560	3.1	3500	5420	
C 41 3_31.2	31.2	90	450	4.5	3090	4510	45	570	2.9	3500	5670	
C 41 3_36.8	36.8	76	480	4.1	3070	4710	38	600	2.6	3500	5960	
C 41 3_40.3	40.3	69	485	3.8	3100	4940	35	600	2.3	3500	6280	
C 41 3_47.0	47.0	60	515	3.5	3070	5140	29.8	600	2.0	3500	6720	
C 41 3_51.5	51.5	54	525	3.2	3090	5360	27.2	600	1.8	3500	7000	
C 41 3_58.7	58.7	48	550	3.0	3070	5550	23.9	600	1.6	3500	7000	
C 41 3_64.3	64.3	44	560	2.7	3090	5800	21.8	600	1.5	3500	7000	
C 41 3_74.4	74.4	38	590	2.5	3060	6040	18.8	600	1.3	3500	7000	
C 41 3_81.5	81.5	34	600	2.3	3090	6310	17.2	600	1.2	3500	7000	
C 41 3_93.3	93.3	30	600	2.0	3080	6700	15.0	600	1.0	3500	7000	
C 41 3_102.3	102.3	27.4	600	1.8	3110	7000	13.7	600	0.92	3500	7000	
C 41 3_110.1	110.1	25.4	600	1.7	3090	7000	12.7	600	0.86	3500	7000	
C 41 3_120.6	120.6	23.2	600	1.6	3110	7000	11.6	600	0.78	3500	7000	
C 41 3_132.9	132.9	21.1	600	1.4	3090	7000	10.5	600	0.71	3500	7000	
C 41 3_145.6	145.6	19.2	600	1.3	3120	7000	9.6	600	0.65	3500	7000	
C 41 3_164.1	164.1	17.1	600	1.2	3100	7000	8.5	600	0.58	3500	7000	
C 41 3_179.9	179.9	15.6	600	1.1	3120	7000	7.8	600	0.53	3500	7000	
C 41 3_190.8	190.8	14.7	600	0.99	3110	7000	7.3	600	0.50	3500	7000	
C 41 3_209.1	209.1	13.4	600	0.90	3130	7000	6.7	600	0.45	3500	7000	
C 41 4_239.9	239.9	11.7	600	0.81	1480	7000	5.8	600	0.40	1910	7000	
C 41 4_263.0	263.0	10.6	600	0.74	1500	7000	5.3	600	0.37	1920	7000	
C 41 4_304.2	304.2	9.2	600	0.64	1520	7000	4.6	600	0.32	1950	7000	
C 41 4_333.4	333.4	8.4	600	0.58	1530	7000	4.2	600	0.29	1960	7000	
C 41 4_381.8	381.8	7.3	600	0.51	1540	7000	3.7	600	0.25	1970	7000	
C 41 4_418.5	418.5	6.7	600	0.46	1550	7000	3.3	600	0.23	1980	7000	
C 41 4_450.2	450.2	6.2	600	0.43	1560	7000	3.1	600	0.21	1990	7000	
C 41 4_493.5	493.5	5.7	600	0.39	1570	7000	2.8	600	0.20	2000	7000	
C 41 4_543.5	543.5	5.2	600	0.36	1570	7000	2.6	600	0.18	2000	7000	
C 41 4_595.8	595.8	4.7	600	0.32	1580	7000	2.3	600	0.16	2010	7000	
C 41 4_671.3	671.3	4.2	600	0.29	1590	7000	2.1	600	0.14	2020	7000	
C 41 4_735.9	735.9	3.8	600	0.26	1590	7000	1.9	600	0.13	2020	7000	
C 41 4_780.4	780.4	3.6	600	0.25	1600	7000	1.8	600	0.12	2030	7000	
C 41 4_855.5	855.5	3.3	600	0.23	1600	7000	1.6	600	0.11	2030	7000	



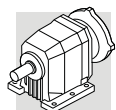

	i	$n_1 = 900 \text{ min}^{-1}$					$n_1 = 500 \text{ min}^{-1}$					
		n_2 min^{-1}	M_{n2} Nm	P_{n1} kW	R_{n1} N	R_{n2} N	n_2 min^{-1}	M_{n2} Nm	P_{n1} kW	R_{n1} N	R_{n2} N	
C 41 2_2.7	2.7	333	245	9.0	2560	2650	185	245	5.0	3500	3590	125
C 41 2_3.6	3.6	250	255	7.0	2710	3050	139	255	3.9	3500	4090	
C 41 2_4.7	4.7	191	260	5.5	2900	3440	106	260	3.0	3500	4570	
C 41 2_6.0	6.0	150	260	4.3	3080	3890	83	260	2.4	3500	5110	
C 41 2_6.4	6.4	141	400	6.2	3310	3780	78	490	4.2	3500	4580	
C 41 2_7.1	7.1	127	415	5.8	3460	3940	70	500	3.9	3500	4820	
C 41 2_8.6	8.6	105	445	5.1	3360	4180	58	500	3.2	3500	5290	
C 41 2_9.6	9.6	94	450	4.7	3500	4410	52	500	2.9	3500	5600	
C 41 2_11.2	11.2	80	490	4.3	3500	4520	45	500	2.5	3500	5980	
C 41 2_12.4	12.4	73	495	4.0	3500	4780	40	500	2.2	3500	6320	
C 41 2_14.2	14.2	63	500	3.5	3500	5060	35	500	1.9	3500	6700	
C 41 2_15.8	15.8	57	500	3.1	3500	5370	32	500	1.7	3500	7000	
C 41 2_17.8	17.8	51	500	2.8	3500	5650	28.1	500	1.5	3500	7000	
C 41 2_19.8	19.8	45	500	2.5	3500	5970	25.3	500	1.4	3500	7000	
C 41 2_22.6	22.6	40	500	2.2	3500	6320	22.1	500	1.2	3500	7000	
C 41 2_25.0	25.0	36	500	2.0	3500	6670	20.0	500	1.1	3500	7000	
C 41 2_28.3	28.3	32	500	1.8	3500	7000	17.7	500	0.97	3500	7000	
C 41 2_31.4	31.4	28.7	500	1.6	3500	7000	15.9	500	0.88	3500	7000	
C 41 2_33.4	33.4	26.9	500	1.5	3500	7000	15.0	500	0.83	3500	7000	
C 41 2_37.1	37.1	24.3	500	1.3	3500	7000	13.5	500	0.74	3500	7000	
C 41 2_44.8	44.8	20.1	500	1.1	3500	7000	11.2	500	0.62	3500	7000	
C 41 3_28.5	28.5	32	600	2.1	3500	6530	17.5	600	1.2	3500	7000	
C 41 3_31.2	31.2	28.8	600	1.9	3500	6870	16.0	600	1.1	3500	7000	
C 41 3_36.8	36.8	24.5	600	1.7	3500	7000	13.6	600	0.92	3500	7000	
C 41 3_40.3	40.3	22.3	600	1.5	3500	7000	12.4	600	0.84	3500	7000	
C 41 3_47.0	47.0	19.1	600	1.3	3500	7000	10.6	600	0.72	3500	7000	
C 41 3_51.5	51.5	17.5	600	1.2	3500	7000	9.7	600	0.66	3500	7000	
C 41 3_58.7	58.7	15.3	600	1.0	3500	7000	8.5	600	0.58	3500	7000	
C 41 3_64.3	64.3	14.0	600	0.95	3500	7000	7.8	600	0.53	3500	7000	
C 41 3_74.4	74.4	12.1	600	0.82	3500	7000	6.7	600	0.45	3500	7000	
C 41 3_81.5	81.5	11.0	600	0.75	3500	7000	6.1	600	0.41	3500	7000	
C 41 3_93.3	93.3	9.6	600	0.65	3500	7000	5.4	600	0.36	3500	7000	
C 41 3_102.3	102.3	8.8	600	0.59	3500	7000	4.9	600	0.33	3500	7000	
C 41 3_110.1	110.1	8.2	600	0.55	3500	7000	4.5	600	0.31	3500	7000	
C 41 3_120.6	120.6	7.5	600	0.50	3500	7000	4.1	600	0.28	3500	7000	
C 41 3_132.9	132.9	6.8	600	0.46	3500	7000	3.8	600	0.25	3500	7000	
C 41 3_145.6	145.6	6.2	600	0.42	3500	7000	3.4	600	0.23	3500	7000	
C 41 3_164.1	164.1	5.5	600	0.37	3500	7000	3.0	600	0.21	3500	7000	
C 41 3_179.9	179.9	5.0	600	0.34	3500	7000	2.8	600	0.19	3500	7000	
C 41 3_190.8	190.8	4.7	600	0.32	3500	7000	2.6	600	0.18	3500	7000	
C 41 3_209.1	209.1	4.3	600	0.29	3500	7000	2.4	600	0.16	3500	7000	
C 41 4_239.9	239.9	3.8	600	0.26	2200	7000	2.1	600	0.14	2200	7000	
C 41 4_263.0	263.0	3.4	600	0.24	2200	7000	1.9	600	0.13	2200	7000	
C 41 4_304.2	304.2	3.0	600	0.20	2200	7000	1.6	600	0.11	2200	7000	
C 41 4_333.4	333.4	2.7	600	0.19	2200	7000	1.5	600	0.10	2200	7000	
C 41 4_381.8	381.8	2.4	600	0.16	2200	7000	1.3	600	0.09	2200	7000	
C 41 4_418.5	418.5	2.2	600	0.15	2200	7000	1.2	600	0.08	2200	7000	
C 41 4_450.2	450.2	2.0	600	0.14	2200	7000	1.1	600	0.08	2200	7000	
C 41 4_493.5	493.5	1.8	600	0.13	2200	7000	1.0	600	0.07	2200	7000	
C 41 4_543.5	543.5	1.7	600	0.11	2200	7000	0.92	600	0.06	2200	7000	
C 41 4_595.8	595.8	1.5	600	0.10	2200	7000	0.84	600	0.06	2200	7000	
C 41 4_671.3	671.3	1.3	600	0.09	2200	7000	0.74	600	0.05	2200	7000	
C 41 4_735.9	735.9	1.2	600	0.08	2200	7000	0.68	600	0.05	2200	7000	
C 41 4_780.4	780.4	1.2	600	0.08	2200	7000	0.64	600	0.04	2200	7000	
C 41 4_855.5	855.5	1.1	600	0.07	2200	7000	0.58	600	0.04	2200	7000	

**C 51****1000 Nm**

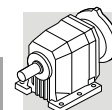
	i	$n_1 = 2800 \text{ min}^{-1}$					$n_1 = 1400 \text{ min}^{-1}$					
		n_2 min^{-1}	M_{n2} Nm	P_{n1} kW	R_{n1} N	R_{n2} N	n_2 min^{-1}	M_{n2} Nm	P_{n1} kW	R_{n1} N	R_{n2} N	
C 51 2_2.6	2.6	1077	315	37	980	3340	538	400	24	1390	4200	128
C 51 2_3.3	3.3	848	340	32	1070	3610	424	420	19.6	1650	4580	
C 51 2_4.5	4.5	622	370	25	1170	4010	311	435	14.9	2010	5180	
C 51 2_5.6	5.6	500	390	21	1290	4380	250	435	12.0	2400	5760	
C 51 2_7.0	7.0	400	500	22	2270	4760	200	630	13.9	2860	6000	
C 51 2_7.8	7.8	359	510	20	2360	4940	179	640	12.7	2980	6230	
C 51 2_8.8	8.8	318	545	19.1	2300	5120	159	685	12.0	2900	6450	
C 51 2_9.8	9.8	286	545	17.2	2410	5350	143	685	10.8	3030	6750	
C 51 2_11.8	11.8	237	610	16.0	2310	5620	119	770	10.1	2910	7080	
C 51 2_13.1	13.1	214	595	14.0	2440	5930	107	750	8.8	3070	7470	
C 51 2_15.0	15.0	187	660	13.6	2330	6080	93	800	8.2	2980	7770	
C 51 2_16.6	16.6	169	640	11.9	2460	6420	84	795	7.4	3120	8130	
C 51 2_18.9	18.9	148	695	11.3	2330	6630	74	800	6.5	3050	8620	
C 51 2_21.0	21.0	133	675	9.9	2460	7000	67	795	5.8	3180	9020	
C 51 2_23.4	23.4	120	735	9.7	2320	7160	60	800	5.3	3110	9460	
C 51 2_25.9	25.9	108	715	8.5	2460	7550	54	795	4.7	3230	9890	
C 51 2_29.8	29.8	94	795	8.2	2310	7770	47	800	4.1	3180	10000	
C 51 2_33.0	33.0	85	775	7.2	2440	8190	42	795	3.7	3300	10000	
C 51 2_36.4	36.4	77	750	6.4	2390	8660	38	790	3.3	3220	10000	
C 51 2_40.4	40.4	69	795	6.1	2440	8870	35	795	3.0	3320	10000	
C 51 2_43.1	43.1	65	730	5.2	2450	9380	32	770	2.8	3280	10000	
C 51 2_47.8	47.8	59	800	5.2	2460	9530	29.3	800	2.6	3350	10000	
C 51 2_51.4	51.4	54	665	4.0	2550	10000	27.2	700	2.1	3390	10000	
C 51 2_57.0	57.0	49	745	4.0	2540	10000	24.6	785	2.1	3380	10000	
C 51 3_21.8	21.8	128	720	10.4	2870	6940	64	905	6.5	3500	8750	
C 51 3_23.9	23.9	117	730	9.6	2910	7230	59	920	6.1	3500	9110	
C 51 3_27.4	27.4	102	770	8.9	2890	7510	51	970	5.6	3500	9470	
C 51 3_30.1	30.1	93	780	8.2	2930	7830	47	1000	5.2	3500	9810	
C 51 3_37.0	37.0	76	840	7.2	2910	8330	38	1000	4.3	3500	10000	
C 51 3_40.5	40.5	69	855	6.7	2940	8670	35	1000	3.9	3500	10000	
C 51 3_46.7	46.7	60	905	6.1	2920	9020	30	1000	3.4	3500	10000	
C 51 3_51.2	51.2	55	920	5.7	2950	9390	27.3	1000	3.1	3500	10000	
C 51 3_59.0	59.0	47	970	5.2	2910	9780	23.7	1000	2.7	3500	10000	
C 51 3_64.6	64.6	43	1000	4.9	2940	10000	21.7	1000	2.4	3500	10000	
C 51 3_72.9	72.9	38	1000	4.3	2920	10000	19.2	1000	2.2	3500	10000	
C 51 3_79.9	79.9	35	1000	3.9	2960	10000	17.5	1000	2.0	3500	10000	
C 51 3_93.0	93.0	30	1000	3.4	2950	10000	15.1	1000	1.7	3500	10000	
C 51 3_101.8	101.8	27.5	1000	3.1	2990	10000	13.8	1000	1.5	3500	10000	
C 51 3_113.6	113.6	24.6	1000	2.8	2960	10000	12.3	1000	1.4	3500	10000	
C 51 3_124.4	124.4	22.5	1000	2.5	3000	10000	11.3	1000	1.3	3500	10000	
C 51 3_134.6	134.6	20.8	1000	2.3	2970	10000	10.4	1000	1.2	3500	10000	
C 51 3_147.4	147.4	19.0	1000	2.1	3010	10000	9.5	1000	1.1	3500	10000	
C 51 3_160.5	160.5	17.4	1000	2.0	2980	10000	8.7	1000	0.98	3500	10000	
C 51 3_175.8	175.8	15.9	1000	1.8	3020	10000	8.0	1000	0.90	3500	10000	
C 51 3_197.9	197.9	14.1	1000	1.6	2980	10000	7.1	1000	0.80	3500	10000	
C 51 3_216.7	216.7	12.9	1000	1.5	3020	10000	6.5	1000	0.73	3500	10000	
C 51 4_240.9	240.9	11.6	1000	1.3	2100	10000	5.8	1000	0.67	2200	10000	
C 51 4_263.8	263.8	10.6	1000	1.2	2120	10000	5.3	1000	0.61	2200	10000	
C 51 4_297.8	297.8	9.4	1000	1.1	2140	10000	4.7	1000	0.54	2200	10000	
C 51 4_326.1	326.1	8.6	1000	0.99	2160	10000	4.3	1000	0.49	2200	10000	
C 51 4_379.6	379.6	7.4	1000	0.85	2190	10000	3.7	1000	0.42	2200	10000	
C 51 4_415.7	415.7	6.7	1000	0.78	2200	10000	3.4	1000	0.39	2200	10000	
C 51 4_463.9	463.9	6.0	1000	0.69	2200	10000	3.0	1000	0.35	2200	10000	
C 51 4_508.0	508.0	5.5	1000	0.63	2200	10000	2.8	1000	0.32	2200	10000	
C 51 4_549.7	549.7	5.1	1000	0.59	2200	10000	2.5	1000	0.29	2200	10000	
C 51 4_602.0	602.0	4.7	1000	0.54	2200	10000	2.3	1000	0.27	2200	10000	
C 51 4_655.4	655.4	4.3	1000	0.49	2200	10000	2.1	1000	0.25	2200	10000	
C 51 4_717.7	717.7	3.9	1000	0.45	2200	10000	2.0	1000	0.22	2200	10000	
C 51 4_808.0	808.0	3.5	1000	0.40	2200	10000	1.7	1000	0.20	2200	10000	
C 51 4_884.9	884.9	3.2	1000	0.36	2200	10000	1.6	1000	0.18	2200	10000	



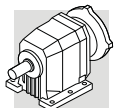

	i	$n_1 = 900 \text{ min}^{-1}$					$n_1 = 500 \text{ min}^{-1}$					
		n_2 min ⁻¹	M_{n2} Nm	P_{n1} kW	R_{n1} N	R_{n2} N	n_2 min ⁻¹	M_{n2} Nm	P_{n1} kW	R_{n1} N	R_{n2} N	
C 51 2_2.6	2.6	346	400	15.3	2560	5130	192	400	8.5	3500	6620	128
C 51 2_3.3	3.3	273	420	12.6	2710	5590	152	420	7.0	3500	7200	
C 51 2_4.5	4.5	200	435	9.6	2900	6300	111	435	5.3	3500	8070	
C 51 2_5.6	5.6	161	435	7.7	3080	6970	89	435	4.3	3500	8880	
C 51 2_7.0	7.0	129	730	10.3	3310	6950	71	800	6.3	3500	8760	
C 51 2_7.8	7.8	115	740	9.4	3460	7220	64	800	5.7	3500	9140	
C 51 2_8.8	8.8	102	795	9.0	3360	7470	57	800	5.0	3500	9680	
C 51 2_9.8	9.8	92	800	8.1	3500	7790	51	800	4.5	3500	10000	
C 51 2_11.8	11.8	76	800	6.7	3500	8530	42	800	3.7	3500	10000	
C 51 2_13.1	13.1	69	800	6.1	3500	8900	38	800	3.4	3500	10000	
C 51 2_15.0	15.0	60	800	5.3	3500	9450	33	800	2.9	3500	10000	
C 51 2_16.6	16.6	54	800	4.8	3500	9850	30	800	2.7	3500	10000	
C 51 2_18.9	18.9	48	800	4.2	3500	10000	26.5	800	2.3	3500	10000	
C 51 2_21.0	21.0	43	800	3.8	3500	10000	23.8	800	2.1	3500	10000	
C 51 2_23.4	23.4	38	800	3.4	3500	10000	21.4	800	1.9	3500	10000	
C 51 2_25.9	25.9	35	800	3.1	3500	10000	19.3	800	1.7	3500	10000	
C 51 2_29.8	29.8	30	800	2.7	3500	10000	16.8	800	1.5	3500	10000	
C 51 2_33.0	33.0	27.3	800	2.4	3500	10000	15.2	800	1.3	3500	10000	
C 51 2_36.4	36.4	24.7	800	2.2	3500	10000	13.7	800	1.2	3500	10000	
C 51 2_40.4	40.4	22.3	800	2.0	3500	10000	12.4	800	1.1	3500	10000	
C 51 2_43.1	43.1	20.9	800	1.8	3500	10000	11.6	800	1.0	3500	10000	
C 51 2_47.8	47.8	18.8	800	1.7	3500	10000	10.5	800	0.92	3500	10000	
C 51 2_51.4	51.4	17.5	725	1.4	3500	10000	9.7	755	0.81	3500	10000	
C 51 2_57.0	57.0	15.8	795	1.4	3500	10000	8.8	795	0.77	3500	10000	
C 51 3_21.8	21.8	41	1000	4.6	3500	10000	22.9	1000	2.6	3500	10000	
C 51 3_23.9	23.9	38	1000	4.2	3500	10000	20.9	1000	2.4	3500	10000	
C 51 3_27.4	27.4	33	1000	3.7	3500	10000	18.2	1000	2.1	3500	10000	
C 51 3_30.1	30.1	29.9	1000	3.4	3500	10000	16.6	1000	1.9	3500	10000	
C 51 3_37.0	37.0	24.3	1000	2.7	3500	10000	13.5	1000	1.5	3500	10000	
C 51 3_40.5	40.5	22.2	1000	2.5	3500	10000	12.3	1000	1.4	3500	10000	
C 51 3_46.7	46.7	19.3	1000	2.2	3500	10000	10.7	1000	1.2	3500	10000	
C 51 3_51.2	51.2	17.6	1000	2.0	3500	10000	9.8	1000	1.1	3500	10000	
C 51 3_59.0	59.0	15.3	1000	1.7	3500	10000	8.5	1000	0.95	3500	10000	
C 51 3_64.6	64.6	13.9	1000	1.6	3500	10000	7.7	1000	0.87	3500	10000	
C 51 3_72.9	72.9	12.3	1000	1.4	3500	10000	6.9	1000	0.77	3500	10000	
C 51 3_79.9	79.9	11.3	1000	1.3	3500	10000	6.3	1000	0.70	3500	10000	
C 51 3_93.0	93.0	9.7	1000	1.1	3500	10000	5.4	1000	0.61	3500	10000	
C 51 3_101.8	101.8	8.8	1000	1.0	3500	10000	4.9	1000	0.55	3500	10000	
C 51 3_113.6	113.6	7.9	1000	0.89	3500	10000	4.4	1000	0.50	3500	10000	
C 51 3_124.4	124.4	7.2	1000	0.81	3500	10000	4.0	1000	0.45	3500	10000	
C 51 3_134.6	134.6	6.7	1000	0.75	3500	10000	3.7	1000	0.42	3500	10000	
C 51 3_147.4	147.4	6.1	1000	0.69	3500	10000	3.4	1000	0.38	3500	10000	
C 51 3_160.5	160.5	5.6	1000	0.63	3500	10000	3.1	1000	0.35	3500	10000	
C 51 3_175.8	175.8	5.1	1000	0.58	3500	10000	2.8	1000	0.32	3500	10000	
C 51 3_197.9	197.9	4.5	1000	0.51	3500	10000	2.5	1000	0.28	3500	10000	
C 51 3_216.7	216.7	4.2	1000	0.47	3500	10000	2.3	1000	0.26	3500	10000	
C 51 4_240.9	240.9	3.7	1000	0.43	2200	10000	2.1	1000	0.24	2200	10000	
C 51 4_263.8	263.8	3.4	1000	0.39	2200	10000	1.9	1000	0.22	2200	10000	
C 51 4_297.8	297.8	3.0	1000	0.35	2200	10000	1.7	1000	0.19	2200	10000	
C 51 4_326.1	326.1	2.8	1000	0.32	2200	10000	1.5	1000	0.18	2200	10000	
C 51 4_379.6	379.6	2.4	1000	0.27	2200	10000	1.3	1000	0.15	2200	10000	
C 51 4_415.7	415.7	2.2	1000	0.25	2200	10000	1.2	1000	0.14	2200	10000	
C 51 4_463.9	463.9	1.9	1000	0.22	2200	10000	1.1	1000	0.12	2200	10000	
C 51 4_508.0	508.0	1.8	1000	0.20	2200	10000	1.0	1000	0.11	2200	10000	
C 51 4_549.7	549.7	1.6	1000	0.19	2200	10000	0.91	1000	0.10	2200	10000	
C 51 4_602.0	602.0	1.5	1000	0.17	2200	10000	0.83	1000	0.10	2200	10000	
C 51 4_655.4	655.4	1.4	1000	0.16	2200	10000	0.76	1000	0.09	2200	10000	
C 51 4_717.7	717.7	1.3	1000	0.14	2200	10000	0.70	1000	0.08	2200	10000	
C 51 4_808.0	808.0	1.1	1000	0.13	2200	10000	0.62	1000	0.07	2200	10000	
C 51 4_884.9	884.9	1.0	1000	0.12	2200	10000	0.57	1000	0.07	2200	10000	





C 61

1600 Nm

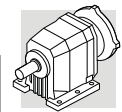

	i	$n_1 = 2800 \text{ min}^{-1}$					$n_1 = 1400 \text{ min}^{-1}$					
		n_2 min^{-1}	M_{n2} Nm	P_{n1} kW	R_{n1} N	R_{n2} N	n_2 min^{-1}	M_{n2} Nm	P_{n1} kW	R_{n1} N	R_{n2} N	
C 61 2_2.8	2.8	1000	445	49	—	4670	500	550	30	770	5930	131
C 61 2_3.7	3.7	757	530	44	—	4950	378	575	24	1730	6600	
C 61 2_4.6	4.6	609	575	39	—	5280	304	600	20	2150	7130	
C 61 2_6.0	6.0	467	575	30	—	6000	233	625	16.1	2700	7950	
C 61 2_6.7	6.7	418	900	41	2230	5600	209	1130	26	2850	7060	
C 61 2_7.5	7.5	373	1000	41	2220	5620	187	1250	26	2900	7110	
C 61 2_8.8	8.8	318	1000	35	2290	6080	159	1250	22	2980	7690	
C 61 2_9.8	9.8	286	1100	35	2380	6140	143	1350	21	3330	7850	
C 61 2_10.9	10.9	257	1050	30	2530	6590	128	1350	19.1	2940	8210	
C 61 2_12.1	12.1	231	1150	29	2670	6670	116	1350	17.2	3600	8730	
C 61 2_14.3	14.3	196	1150	25	2450	7220	98	1350	14.6	3590	9430	
C 61 2_15.9	15.9	176	1250	24	2660	7350	88	1350	13.1	3780	9990	
C 61 2_17.7	17.7	158	1200	21	2540	7850	79	1350	11.8	3700	10400	
C 61 2_19.6	19.6	143	1300	20	2780	8000	71	1350	10.6	3890	11000	
C 61 2_22.4	22.4	125	1250	17.2	2630	8650	63	1350	9.3	3810	11600	
C 61 2_24.8	24.8	113	1350	16.8	2840	8840	56	1350	8.4	3980	12300	
C 61 2_27.4	27.4	102	1300	14.6	2600	9390	51	1350	7.6	3880	12800	
C 61 2_30.4	30.4	92	1350	13.7	2900	9770	46	1350	6.9	4050	13500	
C 61 2_34.2	34.2	82	1165	10.5	3020	10900	41	1225	5.5	4090	14500	
C 61 2_38.0	38.0	74	1280	10.4	3030	11100	37	1350	5.5	4100	14800	
C 61 3_26.8	26.8	104	1140	13.4	3740	9810	52	1435	8.4	4700	12400	
C 61 3_29.4	29.4	95	1160	12.4	3780	10200	48	1465	7.9	4700	12900	
C 61 3_33.0	33.0	85	1210	11.6	3750	10600	42	1525	7.3	4700	13300	
C 61 3_36.1	36.1	78	1235	10.8	3800	11000	39	1555	6.8	4700	13800	
C 61 3_43.4	43.4	65	1315	9.6	3760	11600	32	1600	5.8	4700	14800	
C 61 3_47.6	47.6	59	1340	8.9	3810	12100	29.4	1600	5.3	4700	15500	
C 61 3_53.5	53.5	52	1400	8.2	3760	12500	26.2	1600	4.7	4700	16000	
C 61 3_58.6	58.6	48	1430	7.7	3810	13000	23.9	1600	4.3	4700	16000	
C 61 3_67.7	67.7	41	1505	7.0	3750	13500	20.7	1600	3.7	4700	16000	
C 61 3_74.2	74.2	38	1535	6.5	3800	14100	18.9	1600	3.4	4700	16000	
C 61 3_83.0	83.0	34	1600	6.1	3740	14500	16.9	1600	3.0	4700	16000	
C 61 3_91.0	91.0	31	1600	5.5	3800	15200	15.4	1600	2.8	4700	16000	
C 61 3_103.6	103.6	27.0	1600	4.9	3760	16000	13.5	1600	2.4	4700	16000	
C 61 3_113.6	113.6	24.6	1600	4.4	3820	16000	12.3	1600	2.2	4700	16000	
C 61 3_128.1	128.1	21.9	1600	3.9	3790	16000	10.9	1600	2.0	4700	16000	
C 61 3_140.5	140.5	19.9	1600	3.6	3840	16000	10.0	1600	1.8	4700	16000	
C 61 3_150	150.0	18.7	1600	3.4	3800	16000	9.3	1600	1.7	4700	16000	
C 61 3_164.5	164.5	17.0	1600	3.1	3850	16000	8.5	1600	1.5	4700	16000	
C 61 3_178.6	178.6	15.7	1600	2.8	3800	16000	7.8	1600	1.4	4700	16000	
C 61 3_195.8	195.8	14.3	1600	2.6	3860	16000	7.2	1600	1.3	4700	16000	
C 61 4_217.4	217.4	12.9	1600	2.4	3020	16000	6.4	1600	1.2	3500	16000	
C 61 4_238.3	238.3	11.7	1600	2.2	3060	16000	5.9	1600	1.1	3500	16000	
C 61 4_275.3	275.3	10.2	1600	1.9	3100	16000	5.1	1600	0.94	3500	16000	
C 61 4_301.7	301.7	9.3	1600	1.7	3130	16000	4.6	1600	0.85	3500	16000	
C 61 4_337.7	337.7	8.3	1600	1.5	3160	16000	4.1	1600	0.76	3500	16000	
C 61 4_370.1	370.1	7.6	1600	1.4	3180	16000	3.8	1600	0.70	3500	16000	
C 61 4_421.5	421.5	6.6	1600	1.2	3200	16000	3.3	1600	0.61	3500	16000	
C 61 4_462.0	462.0	6.1	1600	1.1	3220	16000	3.0	1600	0.56	3500	16000	
C 61 4_521.1	521.1	5.4	1600	0.99	3240	16000	2.7	1600	0.49	3500	16000	
C 61 4_571.2	571.2	4.9	1600	0.90	3250	16000	2.5	1600	0.45	3500	16000	
C 61 4_610.1	610.1	4.6	1600	0.84	3260	16000	2.3	1600	0.42	3500	16000	
C 61 4_668.8	668.8	4.2	1600	0.77	3280	16000	2.1	1600	0.39	3500	16000	
C 61 4_726.3	726.3	3.9	1600	0.71	3290	16000	1.9	1600	0.35	3500	16000	
C 61 4_796.1	796.1	3.5	1600	0.65	3300	16000	1.8	1600	0.32	3500	16000	

(-) Interpellare il ns. servizio tecnico comunicando i dati relativi al carico radiale (senso di rotazione, orientamento, posizione)
 (-) Contact our technical service department advising radial load data (rotation direction, orientation, position)
 (-) Nehmen Sie bitte Kontakt mit unserem Applikationsdienst und Querkraftsdaten angeben (Drehrichtung, Orientierung, Anordnung)
 (-) Consulter notre service technique en donnant les détails concernant la charge radiale (sens de rotation, indexage, position)



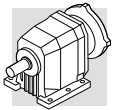

	i	$n_1 = 900 \text{ min}^{-1}$					$n_1 = 500 \text{ min}^{-1}$					
		n_2 min^{-1}	M_{n2} Nm	P_{n1} kW	R_{n1} N	R_{n2} N	n_2 min^{-1}	M_{n2} Nm	P_{n1} kW	R_{n1} N	R_{n2} N	
C 61 2_2.8	2.8	321	565	20	2840	7150	179	665	13.1	4050	8790	131
C 61 2_3.7	3.7	243	625	16.8	3000	7800	135	665	9.9	4700	9860	
C 61 2_4.6	4.6	196	665	14.3	3170	8380	109	665	8.0	4700	10760	
C 61 2_6.0	6.0	150	665	11.0	4120	9440	83	665	6.1	4700	12000	
C 61 2_6.7	6.7	134	1350	20	2850	8050	75	1350	11.1	4700	10800	
C 61 2_7.5	7.5	120	1350	17.9	4010	8560	67	1350	9.9	4700	11400	
C 61 2_8.8	8.8	102	1350	15.2	4070	9240	57	1350	8.5	4700	12200	
C 61 2_9.8	9.8	92	1350	13.7	4310	9790	51	1350	7.6	4700	12900	
C 61 2_10.9	10.9	83	1350	12.3	4270	10200	46	1350	6.8	4700	13400	
C 61 2_12.1	12.1	74	1350	11.1	4480	10800	41	1350	6.1	4700	14100	
C 61 2_14.3	14.3	63	1350	9.4	4470	11600	35	1350	5.2	4700	15100	
C 61 2_15.9	15.9	57	1350	8.4	4660	12300	31	1350	4.7	4700	15900	
C 61 2_17.7	17.7	51	1350	7.6	4580	12800	28.2	1350	4.2	4700	16000	
C 61 2_19.6	19.6	46	1350	6.8	4700	13500	25.5	1350	3.8	4700	16000	
C 61 2_22.4	22.4	40	1350	6.0	4690	14200	22.3	1350	3.3	4700	16000	
C 61 2_24.8	24.8	36	1350	5.4	4700	14900	20.2	1350	3.0	4700	16000	
C 61 2_27.4	27.4	33	1350	4.9	4700	15500	18.2	1350	2.7	4700	16000	
C 61 2_30.4	30.4	29.6	1350	4.4	4700	16000	16.4	1350	2.4	4700	16000	
C 61 2_34.2	34.2	26.3	1265	3.7	4700	16000	14.6	1325	2.1	4700	16000	
C 61 2_38.0	38.0	23.7	1350	3.5	4700	16000	13.2	1350	2.0	4700	16000	
C 61 3_26.8	26.8	34	1600	6.0	4700	14500	18.7	1600	3.4	4700	16000	
C 61 3_29.4	29.4	31	1600	5.5	4700	15200	17.0	1600	3.1	4700	16000	
C 61 3_33.0	33.0	27.3	1600	4.9	4700	15900	15.2	1600	2.7	4700	16000	
C 61 3_36.1	36.1	24.9	1600	4.5	4700	16000	13.9	1600	2.5	4700	16000	
C 61 3_43.4	43.4	20.7	1600	3.7	4700	16000	11.5	1600	2.1	4700	16000	
C 61 3_47.6	47.6	18.9	1600	3.4	4700	16000	10.5	1600	1.9	4700	16000	
C 61 3_53.5	53.5	16.8	1600	3.0	4700	16000	9.3	1600	1.7	4700	16000	
C 61 3_58.6	58.6	15.4	1600	2.8	4700	16000	8.5	1600	1.5	4700	16000	
C 61 3_67.7	67.7	13.3	1600	2.4	4700	16000	7.4	1600	1.3	4700	16000	
C 61 3_74.2	74.2	12.1	1600	2.2	4700	16000	6.7	1600	1.2	4700	16000	
C 61 3_83.0	83.0	10.8	1600	2.0	4700	16000	6.0	1600	1.1	4700	16000	
C 61 3_91.0	91.0	9.9	1600	1.8	4700	16000	5.5	1600	0.99	4700	16000	
C 61 3_103.6	103.6	8.7	1600	1.6	4700	16000	4.8	1600	0.87	4700	16000	
C 61 3_113.6	113.6	7.9	1600	1.4	4700	16000	4.4	1600	0.79	4700	16000	
C 61 3_128.1	128.1	7.0	1600	1.3	4700	16000	3.9	1600	0.70	4700	16000	
C 61 3_140.5	140.5	6.4	1600	1.2	4700	16000	3.6	1600	0.64	4700	16000	
C 61 3_150	150.0	6.0	1600	1.1	4700	16000	3.3	1600	0.60	4700	16000	
C 61 3_164.5	164.5	5.5	1600	0.99	4700	16000	3.0	1600	0.55	4700	16000	
C 61 3_178.6	178.6	5.0	1600	0.91	4700	16000	2.8	1600	0.50	4700	16000	
C 61 3_195.8	195.8	4.6	1600	0.83	4700	16000	2.6	1600	0.46	4700	16000	
C 61 4_217.4	217.4	4.1	1600	0.76	3500	16000	2.3	1600	0.42	3500	16000	
C 61 4_238.3	238.3	3.8	1600	0.70	3500	16000	2.1	1600	0.39	3500	16000	
C 61 4_275.3	275.3	3.3	1600	0.60	3500	16000	1.8	1600	0.33	3500	16000	
C 61 4_301.7	301.7	3.0	1600	0.55	3500	16000	1.7	1600	0.31	3500	16000	
C 61 4_337.7	337.7	2.7	1600	0.49	3500	16000	1.5	1600	0.27	3500	16000	
C 61 4_370.1	370.1	2.4	1600	0.45	3500	16000	1.4	1600	0.25	3500	16000	
C 61 4_421.5	421.5	2.1	1600	0.39	3500	16000	1.2	1600	0.22	3500	16000	
C 61 4_462.0	462.0	1.9	1600	0.36	3500	16000	1.1	1600	0.20	3500	16000	
C 61 4_521.1	521.1	1.7	1600	0.32	3500	16000	1.0	1600	0.18	3500	16000	
C 61 4_571.2	571.2	1.6	1600	0.29	3500	16000	0.88	1600	0.16	3500	16000	
C 61 4_610.1	610.1	1.5	1600	0.27	3500	16000	0.82	1600	0.15	3500	16000	
C 61 4_668.8	668.8	1.3	1600	0.25	3500	16000	0.75	1600	0.14	3500	16000	
C 61 4_726.3	726.3	1.2	1600	0.23	3500	16000	0.69	1600	0.13	3500	16000	
C 61 4_796.1	796.1	1.1	1600	0.21	3500	16000	0.63	1600	0.12	3500	16000	



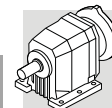

	i	$n_1 = 2800 \text{ min}^{-1}$					$n_1 = 1400 \text{ min}^{-1}$					
		n_2 min ⁻¹	M_{n2} Nm	P_{n1} kW	R_{n1} N	R_{n2} N	n_2 min ⁻¹	M_{n2} Nm	P_{n1} kW	R_{n1} N	R_{n2} N	
C 70 2_4.6	4.6	613	1400	95	—	5590	306	1700	57	—	7100	134
C 70 2_5.9	5.9	479	1550	82	—	5610	239	1900	50	—	6990	
C 70 2_6.3	6.3	448	1600	79	1980	6570	224	1950	48	2630	8250	
C 70 2_7.5	7.5	375	1550	64	—	7130	188	1950	40	—	8400	
C 70 2_8.0	8.0	350	1750	68	1760	6840	175	2100	41	2670	8880	
C 70 2_9.5	9.5	294	1600	52	770	8260	147	2000	32	620	9910	
C 70 2_10.2	10.2	274	1900	57	2000	7200	137	2100	32	4470	10800	
C 70 2_11.2	11.2	250	1600	44	1130	9350	125	2000	28	1070	11300	
C 70 2_13.0	13.0	215	2050	49	1860	7700	107	2100	25	5600	12900	
C 70 2_14.1	14.1	199	1700	37	1100	10120	99	2100	23	1280	12400	
C 70 2_15.3	15.3	183	2100	42	1810	8540	91	2100	21	5860	14300	
C 70 2_16.7	16.7	168	1700	31	1570	11400	84	2050	18.9	2350	14300	
C 70 2_19.3	19.3	145	2100	34	2730	10370	73	2100	16.8	6000	16300	
C 70 2_22.9	22.9	123	2100	28	3160	11760	61	2100	14.2	6060	18000	
C 70 2_27.7	27.7	101	2100	23	3570	13390	51	2100	11.7	6120	19900	
C 70 2_34.7	34.7	81	2100	18.7	3960	15390	40	2100	9.3	6180	22200	
C 70 3_41.3	41.3	68	1900	14.5	5670	18400	34	2300	8.8	7000	22800	
C 70 3_44.7	44.7	63	1900	13.4	5700	19100	31	2300	8.1	7000	23800	
C 70 3_52.2	52.2	54	2050	12.4	5680	19600	26.8	2300	7.0	7000	25000	
C 70 3_56.5	56.5	50	2050	11.4	5710	20400	24.8	2300	6.4	7000	25000	
C 70 3_65.9	65.9	43	2200	10.5	5670	21000	21.3	2300	5.5	7000	25000	
C 70 3_71.3	71.3	39	2200	9.7	5710	21900	19.6	2300	5.1	7000	25000	
C 70 3_81.4	81.4	34	2300	8.9	5680	22700	17.2	2300	4.5	7000	25000	
C 70 3_88.2	88.2	32	2300	8.2	5710	23600	15.9	2300	4.1	7000	25000	
C 70 3_103.8	103.8	27.0	2300	7.0	5700	25000	13.5	2300	3.5	7000	25000	
C 70 3_112.4	112.4	24.9	2300	6.4	5740	25000	12.5	2300	3.2	7000	25000	
C 70 3_126.8	126.8	22.1	2300	5.7	5720	25000	11.0	2300	2.9	7000	25000	
C 70 3_137.4	137.4	20.4	2300	5.3	5750	25000	10.2	2300	2.6	7000	25000	
C 70 3_150.3	150.3	18.6	2300	4.8	5730	25000	9.3	2300	2.4	7000	25000	
C 70 3_162.8	162.8	17.2	2300	4.5	5760	25000	8.6	2300	2.2	7000	25000	
C 70 3_179.2	179.2	15.6	2300	4.0	5740	25000	7.8	2300	2.0	7000	25000	
C 70 3_194.1	194.1	14.4	2300	3.7	5770	25000	7.2	2300	1.9	7000	25000	
C 70 3_220.9	220.9	12.7	2250	3.2	5750	25000	6.3	2250	1.6	7000	25000	
C 70 3_239.3	239.3	11.7	2300	3.0	5770	25000	5.8	2300	1.5	7000	25000	
C 70 4_251.3	251.3	11.1	2300	2.9	2000	25000	5.6	2300	1.5	2620	25000	
C 70 4_272.2	272.2	10.3	2300	2.7	2030	25000	5.1	2300	1.4	2650	25000	
C 70 4_317.9	317.9	8.8	2300	2.3	2030	25000	4.4	2300	1.2	2650	25000	
C 70 4_344.3	344.3	8.1	2300	2.2	2050	25000	4.1	2300	1.1	2670	25000	
C 70 4_409.4	409.4	6.8	2300	1.8	2050	25000	3.4	2300	0.90	2670	25000	
C 70 4_443.5	443.5	6.3	2300	1.7	2070	25000	3.2	2300	0.80	2700	25000	
C 70 4_512.0	512.0	5.5	2300	1.4	2070	25000	2.7	2300	0.70	2680	25000	
C 70 4_554.7	554.7	5.0	2300	1.3	2090	25000	2.5	2300	0.70	2710	25000	
C 70 4_606.8	606.8	4.6	2300	1.2	2080	25000	2.3	2300	0.60	2700	25000	
C 70 4_657.3	657.3	4.3	2300	1.1	2100	25000	2.1	2300	0.60	2720	25000	
C 70 4_736.0	736.0	3.8	2300	1.0	2090	25000	1.9	2300	0.50	2700	25000	
C 70 4_797.3	797.3	3.5	2300	0.90	2110	25000	1.8	2300	0.50	2720	25000	
C 70 4_922.6	922.6	3.0	2300	0.80	2100	25000	1.5	2300	0.40	2710	25000	
C 70 4_999.5	999.5	2.8	2300	0.70	2110	25000	1.4	2300	0.40	2730	25000	
C 70 4_1069	1069	2.6	2300	0.70	2100	25000	1.3	2300	0.30	2720	25000	
C 70 4_1158	1158	2.4	2300	0.60	2100	25000	1.2	2300	0.30	2800	25000	
C 70 4_1362	1362	2.1	2300	0.50	2100	25000	1.0	2300	0.30	2800	25000	
C 70 4_1476	1476	1.9	2300	0.50	2100	25000	0.90	2300	0.30	2800	25000	

(-) Interpellare il ns. servizio tecnico comunicando i dati relativi al carico radiale (senso di rotazione, orientamento, posizione)
 (-) Contact our technical service department advising radial load data (rotation direction, load angle, offset)
 (-) Nehmen Sie bitte Kontakt mit unserem Applikationsdienst und Querkraftsdaten angeben (Drehrichtung, Orientierung, Anordnung)
 (-) Consulter notre service technique en donnant les détails concernant la charge radiale (sens de rotation, indexage, position)



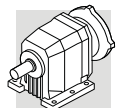

	i	$n_1 = 900 \text{ min}^{-1}$					$n_1 = 500 \text{ min}^{-1}$					
		n_2 min^{-1}	M_{n2} Nm	P_{n1} kW	R_{n1} N	R_{n2} N	n_2 min^{-1}	M_{n2} Nm	P_{n1} kW	R_{n1} N	R_{n2} N	
C 70 2_4.6	4.6	197	1800	39	650	9360	109	1800	22	5500	13900	
C 70 2_5.9	5.9	154	1950	33	560	9980	85	2150	20.0	2890	13400	
C 70 2_6.3	6.3	144	2100	33	4260	10400	80	2100	18.5	7000	15500	
C 70 2_7.5	7.5	121	2100	28	1120	10800	67	2150	15.9	5400	15600	
C 70 2_8.0	8.0	113	2100	26	5800	12500	63	2100	14.5	7000	17800	
C 70 2_9.5	9.5	95	2150	22	2140	12400	53	2150	12.4	6990	18100	
C 70 2_10.2	10.2	88	2100	20.0	6870	14600	49	2100	11.3	7000	20200	
C 70 2_11.2	11.2	80	2150	19.0	2620	14000	45	2150	10.6	7000	19800	
C 70 2_13.0	13.0	69	2100	16.0	7000	16900	38	2100	8.9	7000	22800	
C 70 2_14.1	14.1	64	2150	15.1	3900	16000	35	2150	8.4	7000	22300	
C 70 2_15.3	15.3	59	2100	13.6	7000	18400	33	2100	7.5	7000	24600	
C 70 2_16.7	16.7	54	2050	12.2	5470	18500	29.9	2050	6.8	7000	25000	
C 70 2_19.3	19.3	47	2100	10.8	7000	20700	25.9	2100	6.0	7000	25000	
C 70 2_22.9	22.9	39	2100	9.1	7000	22500	21.9	2100	5.1	7000	25000	
C 70 2_27.7	27.7	32	2100	7.5	7000	24600	18.0	2100	4.2	7000	25000	
C 70 2_34.7	34.7	25.9	2100	6.0	7000	25000	14.4	2100	3.3	7000	25000	
C 70 3_41.3	41.3	21.8	2300	5.6	7000	25000	12.1	2300	3.1	7000	25000	
C 70 3_44.7	44.7	20.1	2300	5.2	7000	25000	11.2	2300	2.9	7000	25000	
C 70 3_52.2	52.2	17.3	2300	4.5	7000	25000	9.6	2300	2.5	7000	25000	
C 70 3_56.5	56.5	15.9	2300	4.1	7000	25000	8.8	2300	2.3	7000	25000	
C 70 3_65.9	65.9	13.7	2300	3.5	7000	25000	7.6	2300	2.0	7000	25000	
C 70 3_71.3	71.3	12.6	2300	3.3	7000	25000	7.0	2300	1.8	7000	25000	
C 70 3_81.4	81.4	11.1	2300	2.9	7000	25000	6.1	2300	1.6	7000	25000	
C 70 3_88.2	88.2	10.2	2300	2.6	7000	25000	5.7	2300	1.5	7000	25000	
C 70 3_103.8	103.8	8.7	2300	2.2	7000	25000	4.8	2300	1.2	7000	25000	
C 70 3_112.4	112.4	8.0	2300	2.1	7000	25000	4.4	2300	1.2	7000	25000	
C 70 3_126.8	126.8	7.1	2300	1.8	7000	25000	3.9	2300	1.0	7000	25000	
C 70 3_137.4	137.4	6.6	2300	1.7	7000	25000	3.6	2300	0.90	7000	25000	
C 70 3_150.3	150.3	6.0	2300	1.6	7000	25000	3.3	2300	0.90	7000	25000	
C 70 3_162.8	162.8	5.5	2300	1.4	7000	25000	3.1	2300	0.80	7000	25000	
C 70 3_179.2	179.2	5.0	2300	1.3	7000	25000	2.8	2300	0.70	7000	25000	
C 70 3_194.1	194.1	4.6	2300	1.2	7000	25000	2.6	2300	0.70	7000	25000	
C 70 3_220.9	220.9	4.1	2250	1.0	7000	25000	2.3	2250	0.60	7000	25000	
C 70 3_239.3	239.3	3.8	2300	1.0	7000	25000	2.1	2300	0.50	7000	25000	
C 70 4_251.3	251.3	3.6	2300	0.90	2000	25000	2.0	2300	0.50	2620	25000	
C 70 4_272.2	272.2	3.3	2300	0.90	2030	25000	1.8	2300	0.50	2650	25000	
C 70 4_317.9	317.9	2.8	2300	0.70	2030	25000	1.6	2300	0.40	2650	25000	
C 70 4_344.3	344.3	2.6	2300	0.70	2050	25000	1.5	2300	0.40	2670	25000	
C 70 4_409.4	409.4	2.2	2300	0.60	2050	25000	1.2	2300	0.30	2670	25000	
C 70 4_443.5	443.5	2.0	2300	0.50	2070	25000	1.1	2300	0.30	2700	25000	
C 70 4_512.0	512.0	1.8	2300	0.50	2070	25000	1.0	2300	0.30	2680	25000	
C 70 4_554.7	554.7	1.6	2300	0.40	2090	25000	0.90	2300	0.20	2710	25000	
C 70 4_606.8	606.8	1.5	2300	0.40	2080	25000	0.80	2300	0.20	2700	25000	
C 70 4_657.3	657.3	1.4	2300	0.40	2100	25000	0.80	2300	0.20	2720	25000	
C 70 4_736.0	736.0	1.2	2300	0.30	2090	25000	0.70	2300	0.20	2700	25000	
C 70 4_797.3	797.3	1.1	2300	0.30	2110	25000	0.60	2300	0.20	2720	25000	
C 70 4_922.6	922.6	1.0	2300	0.30	2100	25000	0.50	2300	0.10	2710	25000	
C 70 4_999.5	999.5	0.90	2300	0.20	2110	25000	0.50	2300	0.10	2730	25000	
C 70 4_1069	1069	0.80	2300	0.20	2100	25000	0.50	2300	0.10	2720	25000	
C 70 4_1158	1158	0.80	2300	0.20	2100	25000	0.40	2300	0.10	2800	25000	
C 70 4_1362	1362	0.70	2300	0.20	2100	25000	0.40	2300	0.10	2800	25000	
C 70 4_1476	1476	0.60	2300	0.20	2100	25000	0.30	2300	0.10	2800	25000	

**C 80****4000 Nm**

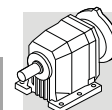
	i	$n_1 = 2800 \text{ min}^{-1}$					$n_1 = 1400 \text{ min}^{-1}$					
		n_2 min^{-1}	M_{n2} Nm	P_{n1} kW	R_{n1} N	R_{n2} N	n_2 min^{-1}	M_{n2} Nm	P_{n1} kW	R_{n1} N	R_{n2} N	
C 80 2_5.6	5.6	496	2400	131	370	10900	248	3100	85	690	12300	137
C 80 2_6.1	6.1	458	2450	124	890	11000	229	3150	80	1380	12700	
C 80 2_7.0	7.0	398	2650	116	350	11000	199	3350	73	910	12900	
C 80 2_7.6	7.6	367	2700	109	890	11300	183	3400	69	1600	13300	
C 80 2_8.9	8.9	316	2800	98	420	12100	158	3500	61	1120	14500	
C 80 2_9.6	9.6	292	3000	96	520	11300	146	3700	59	1380	13900	
C 80 2_11.1	11.1	252	2800	78	1110	14200	126	3500	49	1950	17100	
C 80 2_12.0	12.0	233	3000	77	1200	13500	116	3700	48	2190	16600	
C 80 2_13.8	13.8	203	2800	63	1420	16400	102	3500	39	2330	19800	
C 80 2_14.9	14.9	188	3000	62	1510	15800	94	3700	38	2560	19300	
C 80 2_16.7	16.7	168	2800	52	1840	18500	84	3500	32	2840	22300	
C 80 2_18.1	18.1	155	3000	50	1930	17900	78	3700	32	3060	22000	
C 80 2_20.5	20.5	136	2850	43	2000	20500	68	3550	27	3060	24800	
C 80 2_22.2	22.2	126	3000	42	2210	20300	63	3700	26	3400	24900	
C 80 2_24.0	24.0	117	2850	37	2090	22400	58	3550	23	3180	27000	
C 80 2_25.9	25.9	108	3000	36	2300	22300	54	3700	22	3510	27200	
C 80 2_31.3	31.3	89	3000	30	2480	24700	45	3700	18.2	3730	30000	
C 80 2_39.1	39.1	72	2500	19.7	3820	31000	36	3200	12.6	5060	35000	
C 80 3_43.5	43.5	64	3100	22.5	5610	28700	32	3800	13.8	7000	34800	
C 80 3_47.4	47.4	59	3100	20.6	5660	30000	29.5	3800	12.6	7000	35000	
C 80 3_57.3	57.3	49	3400	18.7	5620	30500	24.4	4000	11.0	7000	35000	
C 80 3_62.5	62.5	45	3400	17.1	5670	31800	22.4	4000	10.1	7000	35000	
C 80 3_70.5	70.5	40	3650	16.3	5620	32200	19.9	4000	8.9	7000	35000	
C 80 3_76.9	76.9	36	3600	14.8	5670	33900	18.2	4000	8.2	7000	35000	
C 80 3_89.3	89.3	31	3900	13.8	5620	34700	15.7	4000	7.1	7000	35000	
C 80 3_97.4	97.4	28.7	3900	12.6	5670	35000	14.4	4000	6.5	7000	35000	
C 80 3_109.5	109.5	25.5	4000	11.5	5630	35000	12.8	4000	5.8	7000	35000	
C 80 3_119.5	119.5	23.4	4000	10.6	5680	35000	11.7	4000	5.3	7000	35000	
C 80 3_136.7	136.7	20.5	4000	9.2	5660	35000	10.2	4000	4.6	7000	35000	
C 80 3_149.1	149.1	18.8	4000	8.5	5700	35000	9.4	4000	4.2	7000	35000	
C 80 3_169.0	169.0	16.6	4000	7.5	5680	35000	8.3	4000	3.7	7000	35000	
C 80 3_184.4	184.4	15.2	4000	6.8	5720	35000	7.6	4000	3.4	7000	35000	
C 80 3_197.9	197.9	14.2	3800	6.1	5710	35000	7.1	3800	3.0	7000	35000	
C 80 3_215.9	215.9	13.0	4000	5.8	5730	35000	6.5	4000	2.9	7000	35000	
C 80 4_261.9	261.9	10.7	4000	4.9	1850	35000	5.3	4000	2.5	2470	35000	
C 80 4_285.7	285.7	9.8	4000	4.5	1890	35000	4.9	4000	2.3	2510	35000	
C 80 4_334.3	334.3	8.4	4000	3.9	1880	35000	4.2	4000	1.9	2500	35000	
C 80 4_364.7	364.7	7.7	4000	3.5	1920	35000	3.8	4000	1.8	2540	35000	
C 80 4_417.5	417.5	6.7	4000	3.1	1910	35000	3.4	4000	1.5	2530	35000	
C 80 4_455.4	455.4	6.1	4000	2.8	1950	35000	3.1	4000	1.4	2570	35000	
C 80 4_529.3	529.3	5.3	4000	2.4	1940	35000	2.6	4000	1.2	2550	35000	
C 80 4_577.4	577.4	4.8	4000	2.2	1970	35000	2.4	4000	1.1	2590	35000	
C 80 4_664.3	664.3	4.2	4000	1.9	1960	35000	2.1	4000	1.0	2570	35000	
C 80 4_724.7	724.7	3.9	4000	1.8	1990	35000	1.9	4000	0.90	2610	35000	
C 80 4_783.4	783.4	3.6	4000	1.6	1970	35000	1.8	4000	0.80	2590	35000	
C 80 4_854.6	854.6	3.3	4000	1.5	2000	35000	1.6	4000	0.80	2620	35000	
C 80 4_945.7	945.7	3.0	4000	1.4	1980	35000	1.5	4000	0.70	2600	35000	
C 80 4_1032	1032	2.7	4000	1.2	2010	35000	1.4	4000	0.60	2630	35000	
C 80 4_1168	1168	2.4	4000	1.1	1980	35000	1.2	4000	0.60	2600	35000	
C 80 4_1274	1274	2.2	4000	1.0	2020	35000	1.1	4000	0.50	2640	35000	
C 80 4_1358	1358	2.1	4000	0.90	1990	35000	1.0	4000	0.50	2610	35000	
C 80 4_1481	1481	1.9	4000	0.90	2030	35000	0.90	4000	0.40	2640	35000	



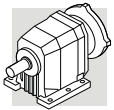

	i	$n_1 = 900 \text{ min}^{-1}$					$n_1 = 500 \text{ min}^{-1}$					
		n_2 min^{-1}	M_{n2} Nm	P_{n1} kW	R_{n1} N	R_{n2} N	n_2 min^{-1}	M_{n2} Nm	P_{n1} kW	R_{n1} N	R_{n2} N	
C 80 2_5.6	5.6	160	3500	62	1480	14400	89	3500	34	4970	21600	137
C 80 2_6.1	6.1	147	3600	58	2100	14400	82	3700	33	5270	21200	
C 80 2_7.0	7.0	128	3500	49	2630	17000	71	3500	27	6130	24600	
C 80 2_7.6	7.6	118	3650	47	3060	16800	66	3650	26	6550	24600	
C 80 2_8.9	8.9	102	3500	39	3330	19900	56	3500	22	6800	27800	
C 80 2_9.6	9.6	94	3700	38	3590	19400	52	3700	21	7000	27700	
C 80 2_11.1	11.1	81	3500	31	4160	22800	45	3500	17.4	7000	31200	
C 80 2_12.0	12.0	75	3700	31	4400	22500	42	3700	17.0	7000	31200	
C 80 2_13.8	13.8	65	3500	25	4540	25700	36	3500	14.0	7000	34700	
C 80 2_14.9	14.9	60	3700	25	4770	25500	34	3700	13.7	7000	34700	
C 80 2_16.7	16.7	54	3500	21	5050	28500	30	3500	11.6	7000	35000	
C 80 2_18.1	18.1	50	3700	20	5280	28400	27.7	3700	11.3	7000	35000	
C 80 2_20.5	20.5	44	3550	17.2	5270	31400	24.4	3550	9.5	7000	35000	
C 80 2_22.2	22.2	40	3700	16.5	5610	31600	22.5	3700	9.2	7000	35000	
C 80 2_24.0	24.0	38	3550	14.7	5390	33800	20.9	3550	8.2	7000	35000	
C 80 2_25.9	25.9	35	3700	14.1	5730	34200	19.3	3700	7.9	7000	35000	
C 80 2_31.3	31.3	28.7	3700	11.7	5940	35000	16.0	3700	6.5	7000	35000	
C 80 2_39.1	39.1	23.0	3200	8.1	7000	35000	12.8	3200	4.5	7000	35000	
C 80 3_43.5	43.5	20.7	4000	9.3	7000	35000	11.5	4000	5.2	7000	35000	
C 80 3_47.4	47.4	19.0	4000	8.5	7000	35000	10.5	4000	4.7	7000	35000	
C 80 3_57.3	57.3	15.7	4000	7.1	7000	35000	8.7	4000	3.9	7000	35000	
C 80 3_62.5	62.5	14.4	4000	6.5	7000	35000	8.0	4000	3.6	7000	35000	
C 80 3_70.5	70.5	12.8	4000	5.7	7000	35000	7.1	4000	3.2	7000	35000	
C 80 3_76.9	76.9	11.7	4000	5.3	7000	35000	6.5	4000	2.9	7000	35000	
C 80 3_89.3	89.3	10.1	4000	4.5	7000	35000	5.6	4000	2.5	7000	35000	
C 80 3_97.4	97.4	9.2	4000	4.2	7000	35000	5.1	4000	2.3	7000	35000	
C 80 3_109.5	109.5	8.2	4000	3.7	7000	35000	4.6	4000	2.1	7000	35000	
C 80 3_119.5	119.5	7.5	4000	3.4	7000	35000	4.2	4000	1.9	7000	35000	
C 80 3_136.7	136.7	6.6	4000	3.0	7000	35000	3.7	4000	1.6	7000	35000	
C 80 3_149.1	149.1	6.0	4000	2.7	7000	35000	3.4	4000	1.5	7000	35000	
C 80 3_169.0	169.0	5.3	4000	2.4	7000	35000	3.0	4000	1.3	7000	35000	
C 80 3_184.4	184.4	4.9	4000	2.2	7000	35000	2.7	4000	1.2	7000	35000	
C 80 3_197.9	197.9	4.5	3800	1.9	7000	35000	2.5	3800	1.1	7000	35000	
C 80 3_215.9	215.9	4.2	4000	1.9	7000	35000	2.3	4000	1.0	7000	35000	
C 80 4_261.9	261.9	3.4	4000	1.6	2950	35000	1.9	4000	0.90	3500	35000	
C 80 4_285.7	285.7	3.2	4000	1.4	2990	35000	1.8	4000	0.80	3500	35000	
C 80 4_334.3	334.3	2.7	4000	1.2	2980	35000	1.5	4000	0.70	3500	35000	
C 80 4_364.7	364.7	2.5	4000	1.1	3020	35000	1.4	4000	0.60	3500	35000	
C 80 4_417.5	417.5	2.2	4000	1.0	3000	35000	1.2	4000	0.60	3500	35000	
C 80 4_455.4	455.4	2.0	4000	0.90	3050	35000	1.1	4000	0.50	3500	35000	
C 80 4_529.3	529.3	1.7	4000	0.80	3030	35000	0.90	4000	0.40	3500	35000	
C 80 4_577.4	577.4	1.6	4000	0.70	3070	35000	0.90	4000	0.40	3500	35000	
C 80 4_664.3	664.3	1.4	4000	0.60	3050	35000	0.80	4000	0.30	3500	35000	
C 80 4_724.7	724.7	1.2	4000	0.60	3090	35000	0.70	4000	0.30	3500	35000	
C 80 4_783.4	783.4	1.1	4000	0.50	3060	35000	0.60	4000	0.30	3500	35000	
C 80 4_854.6	854.6	1.1	4000	0.50	3100	35000	0.60	4000	0.30	3500	35000	
C 80 4_945.7	945.7	1.0	4000	0.40	3070	35000	0.50	4000	0.20	3500	35000	
C 80 4_1032	1032	0.90	4000	0.40	3110	35000	0.50	4000	0.20	3500	35000	
C 80 4_1168	1168	0.80	4000	0.40	3080	35000	0.40	4000	0.20	3500	35000	
C 80 4_1274	1274	0.70	4000	0.30	3110	35000	0.40	4000	0.20	3500	35000	
C 80 4_1358	1358	0.70	4000	0.30	3090	35000	0.40	4000	0.20	3500	35000	
C 80 4_1481	1481	0.60	4000	0.30	3120	35000	0.30	4000	0.20	3500	35000	





C 90

7200 Nm

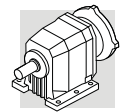

	i	$n_1 = 2800 \text{ min}^{-1}$					$n_1 = 1400 \text{ min}^{-1}$					
		n_2 min^{-1}	M_{n2} Nm	P_{n1} kW	R_{n1} N	R_{n2} N	n_2 min^{-1}	M_{n2} Nm	P_{n1} kW	R_{n1} N	R_{n2} N	
C 90 2_5.2	5.2	542	3500	209	1700	12800	271	4300	128	2170	15800	140
C 90 2_5.6	5.6	500	3600	198	3240	12800	250	4400	121	4250	16000	
C 90 2_6.8	6.8	414	3850	176	1860	13390	207	4750	108	2210	16400	
C 90 2_7.3	7.3	383	3950	167	3470	13460	191	4850	102	4360	16700	
C 90 2_8.3	8.3	336	4150	154	2010	13830	168	5100	94	2540	17100	
C 90 2_9.0	9.0	310	4250	145	3660	13960	155	5200	89	4720	17500	
C 90 2_10.4	10.4	270	4500	134	990	14210	135	5550	83	1150	17400	
C 90 2_11.2	11.2	249	4600	126	2750	14390	125	5650	78	3460	17800	
C 90 2_12.8	12.8	219	4850	117	580	14670	109	5950	72	840	18200	
C 90 2_13.9	13.9	202	4900	109	2700	15330	101	6050	67	3220	18700	
C 90 2_16.0	16.0	175	5050	98	690	16790	88	6200	60	950	20800	
C 90 2_17.3	17.3	162	5300	94	1670	15880	81	6500	58	2200	19800	
C 90 2_18.7	18.7	150	5050	83	1140	19600	75	6200	51	1500	24300	
C 90 2_20.2	20.2	138	5400	82	1540	17920	69	6600	50	2160	22500	
C 90 2_22.9	22.9	122	5050	68	2110	22350	61	6200	42	2700	27600	
C 90 2_24.8	24.8	113	5400	67	2500	21890	56	6600	41	3340	27300	
C 90 2_27.2	27.2	103	4500	51	6160	26030	52	5500	31	7820	32200	
C 90 2_29.4	29.4	95	4800	50	6560	25960	48	5900	31	8130	32000	
C 90 2_35.1	35.1	80	4400	39	8090	29420	40	5400	24	11100	36300	
C 90 3_39.4	39.4	71	6350	51	10800	23900	36	7100	28	13700	32900	
C 90 3_43.0	43.0	65	6500	48	10800	24700	33	7200	26	13800	34000	
C 90 3_50.3	50.3	56	6800	43	10800	26000	27.8	7100	22	13800	37000	
C 90 3_54.9	54.9	51	7000	40	10900	26500	25.5	7200	21	13900	38300	
C 90 3_59.2	59.2	47	7100	38	10800	27700	23.6	7100	18.9	13900	40000	
C 90 3_64.6	64.6	43	7200	35	10900	29100	21.7	7200	17.6	14000	41300	
C 90 3_74.4	74.4	38	7100	30	10900	31900	18.8	7100	15.0	14000	44400	
C 90 3_81.2	81.2	34	7200	28	10900	33000	17.2	7200	14.0	14100	45900	
C 90 3_88.2	88.2	32	7100	25	11000	34800	15.9	7100	12.7	14000	47900	
C 90 3_96.2	96.2	29.1	7200	24	11000	35900	14.5	7200	11.8	14100	49400	
C 90 3_107.0	107.0	26.2	7100	21	11000	38100	13.1	7100	10.5	14100	52100	
C 90 3_116.7	116.7	24.0	7200	19.4	11000	39400	12.0	7200	9.7	14100	53700	
C 90 3_134.1	134.1	20.9	7100	16.7	11000	42400	10.4	7100	8.3	14100	57300	
C 90 3_146.3	146.3	19.1	7200	15.5	11000	43800	9.6	7200	7.8	14200	59000	
C 90 3_157.8	157.8	17.7	7100	14.2	11000	45600	8.9	7100	7.1	14100	60000	
C 90 3_172.1	172.1	16.3	7200	13.2	11000	47100	8.1	7200	6.6	14200	60000	
C 90 4_212.4	212.4	13.2	7200	10.9	—	60000	6.6	7200	5.5	1180	60000	
C 90 4_231.7	231.7	12.1	7200	10.0	—	60000	6.0	7200	5.0	1560	60000	
C 90 4_268.5	268.5	10.4	7200	8.6	—	60000	5.2	7200	4.3	1540	60000	
C 90 4_292.9	292.9	9.6	7200	7.9	—	60000	4.8	7200	4.0	1880	60000	
C 90 4_339.0	339.0	8.3	7200	6.8	—	60000	4.1	7200	3.4	1720	60000	
C 90 4_369.8	369.8	7.6	7200	6.3	—	60000	3.8	7200	3.1	2050	60000	
C 90 4_419.0	419.0	6.7	7200	5.5	—	60000	3.3	7200	2.8	1890	60000	
C 90 4_457.1	457.1	6.1	7200	5.1	—	60000	3.1	7200	2.5	2210	60000	
C 90 4_534.2	534.2	5.2	7200	4.3	—	60000	2.6	7200	2.2	2090	60000	
C 90 4_582.8	582.8	4.8	7200	4.0	—	60000	2.4	7200	2.0	2270	60000	
C 90 4_652.8	652.8	4.3	7200	3.6	—	60000	2.1	7200	1.8	2160	60000	
C 90 4_712.2	712.2	3.9	7200	3.3	—	60000	2.0	7200	1.6	2290	60000	
C 90 4_773.6	773.6	3.3	7200	3.0	—	60000	1.8	7200	1.5	2250	60000	
C 90 4_844.0	844.0	3.0	7200	2.7	—	60000	1.7	7200	1.4	2310	60000	
C 90 4_922.3	922.3	2.8	7200	2.5	—	60000	1.5	7200	1.3	2260	60000	
C 90 4_1006	1006	2.5	7200	2.3	—	60000	1.4	7200	1.2	2320	60000	
C 90 4_1137	1137	2.3	7200	2.0	—	60000	1.2	7200	1.0	2270	60000	
C 90 4_1240	1240	2.2	7200	1.9	—	60000	1.1	7200	0.90	2230	60000	

(-) Interpellare il ns. servizio tecnico comunicando i dati relativi al carico radiale (senso di rotazione, orientamento, posizione)
 (-) Contact our technical service department advising radial load data (rotation direction, load angle, offset)
 (-) Nehmen Sie bitte Kontakt mit unserem Applikationsdienst und Querkraftsdaten angeben (Drehrichtung, Orientierung, Anordnung)
 (-) Consulter notre service technique en donnant les détails concernant la charge radiale (sens de rotation, indexage, position)



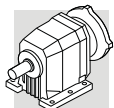

	i	$n_1 = 900 \text{ min}^{-1}$					$n_1 = 500 \text{ min}^{-1}$					
		n_2 min^{-1}	M_{n2} Nm	P_{n1} kW	R_{n1} N	R_{n2} N	n_2 min^{-1}	M_{n2} Nm	P_{n1} kW	R_{n1} N	R_{n2} N	
C 90 2_5.2	5.2	174	4900	94	2560	18200	97	5850	62	3010	21600	140
C 90 2_5.6	5.6	161	5050	89	4640	18100	89	6000	59	5720	21800	
C 90 2_6.8	6.8	133	5450	80	2310	18500	74	6200	51	5130	24600	
C 90 2_7.3	7.3	123	5550	75	4890	18900	68	6550	49	6340	23200	
C 90 2_8.3	8.3	108	5850	70	2700	19300	60	6200	41	8870	27800	
C 90 2_9.0	9.0	100	5950	65	5300	19800	55	6600	40	9660	27600	
C 90 2_10.4	10.4	87	6200	59	2250	21000	48	6200	33	11000	31000	
C 90 2_11.2	11.2	80	6450	57	3960	20400	45	6600	32	11700	30800	
C 90 2_12.8	12.8	70	6250	48	4500	25300	39	6250	27	13200	34100	
C 90 2_13.9	13.9	65	6550	47	5830	24400	36	6550	26	14600	34300	
C 90 2_16.0	16.0	56	6200	38	6570	28700	31	6200	21	15000	38000	
C 90 2_17.3	17.3	52	6550	38	7530	28600	28.9	6550	21	15000	38100	
C 90 2_18.7	18.7	48	6200	33	7120	31000	26.7	6200	18.3	15000	40700	
C 90 2_20.2	20.2	44	6600	32	7780	30800	24.8	6600	18.0	15000	40700	
C 90 2_22.9	22.9	39	6200	27	8310	34200	21.8	6200	14.9	15000	44500	
C 90 2_24.8	24.8	36	6600	26	8950	34100	20.2	6600	14.6	15000	44600	
C 90 2_27.2	27.2	33	5500	20	13400	39200	18.4	5500	11.2	15000	50000	
C 90 2_29.4	29.4	31	5900	19.9	13700	39100	17.0	5900	11.0	15000	50200	
C 90 2_35.1	35.1	25.6	5400	15.3	14100	43800	14.2	5400	8.5	15000	55500	
C 90 3_39.4	39.4	22.8	7100	18.3	15000	40600	12.7	7100	10.1	15000	40600	
C 90 3_43.0	43.0	20.9	7200	17.0	15000	42000	11.6	7200	9.4	15000	42000	
C 90 3_50.3	50.3	17.9	7100	14.3	15000	45400	9.9	7100	7.9	15000	45400	
C 90 3_54.9	54.9	16.4	7200	13.3	15000	46900	9.1	7200	7.4	15000	46900	
C 90 3_59.2	59.2	15.2	7100	12.2	15000	48800	8.4	7100	6.8	15000	48800	
C 90 3_64.6	64.6	13.9	7200	11.3	15000	50400	7.7	7200	6.3	15000	50400	
C 90 3_74.4	74.4	12.1	7100	9.7	15000	53800	6.7	7100	5.4	15000	53800	
C 90 3_81.2	81.2	11.1	7200	9.0	15000	55500	6.2	7200	5.0	15000	55500	
C 90 3_88.2	88.2	10.2	7100	8.2	15000	57800	5.7	7100	4.5	15000	57800	
C 90 3_96.2	96.2	9.4	7200	7.6	15000	59600	5.2	7200	4.2	15000	59600	
C 90 3_107.0	107.0	8.4	7100	6.7	15000	60000	4.7	7100	3.7	15000	60000	
C 90 3_116.7	116.7	7.7	7200	6.3	15000	60000	4.3	7200	3.5	15000	60000	
C 90 3_134.1	134.1	6.7	7100	5.4	15000	60000	3.7	7100	3.0	15000	60000	
C 90 3_146.3	146.3	6.2	7200	5.0	15000	60000	3.4	7200	2.8	15000	60000	
C 90 3_157.8	157.8	5.7	7100	4.6	15000	60000	3.2	7100	2.5	15000	60000	
C 90 3_172.1	172.1	5.2	7200	4.2	15000	60000	2.9	7200	2.4	15000	60000	
C 90 4_212.4	212.4	4.2	7200	3.5	2090	60000	2.4	7200	2.0	3210	60000	
C 90 4_231.7	231.7	3.9	7200	3.2	2460	60000	2.2	7200	1.8	3290	60000	
C 90 4_268.5	268.5	3.4	7200	2.8	2440	60000	1.9	7200	1.5	3300	60000	
C 90 4_292.9	292.9	3.1	7200	2.5	2620	60000	1.7	7200	1.4	3370	60000	
C 90 4_339.0	339.0	2.7	7200	2.2	2590	60000	1.5	7200	1.2	3340	60000	
C 90 4_369.8	369.8	2.4	7200	2.0	2660	60000	1.4	7200	1.1	3420	60000	
C 90 4_419.0	419.0	2.1	7200	1.8	2630	60000	1.2	7200	1.0	3390	60000	
C 90 4_457.1	457.1	2.0	7200	1.6	2700	60000	1.1	7200	0.90	3460	60000	
C 90 4_534.2	534.2	1.7	7200	1.4	2680	60000	0.90	7200	0.80	3380	60000	
C 90 4_582.8	582.8	1.5	7200	1.3	2750	60000	0.90	7200	0.70	3500	60000	
C 90 4_652.8	652.8	1.4	7200	1.1	2700	60000	0.80	7200	0.60	3450	60000	
C 90 4_712.2	712.2	1.3	7200	1.0	2760	60000	0.70	7200	0.60	3500	60000	
C 90 4_773.6	773.6	1.2	7200	1.0	2720	60000	0.60	7200	0.50	3480	60000	
C 90 4_844.0	844.0	1.1	7200	0.90	2790	60000	0.60	7200	0.50	3500	60000	
C 90 4_922.3	922.3	1.0	7200	0.80	2730	60000	0.50	7200	0.40	3490	60000	
C 90 4_1006	1006	0.90	7200	0.70	2800	60000	0.50	7200	0.40	3500	60000	
C 90 4_1137	1137	0.80	7200	0.70	2740	60000	0.40	7200	0.40	3500	60000	
C 90 4_1240	1240	0.70	7200	0.60	2800	60000	0.40	7200	0.30	3500	60000	

**C 100****12000 Nm**

	i	$n_1 = 2800 \text{ min}^{-1}$					$n_1 = 1400 \text{ min}^{-1}$					
		n_2 min^{-1}	M_{n2} Nm	P_{n1} kW	R_{n1} N	R_{n2} N	n_2 min^{-1}	M_{n2} Nm	P_{n1} kW	R_{n1} N	R_{n2} N	
C 100 2_4.9	4.9	569	5500	345	1900	20600	285	6800	213	3790	25300	143
C 100 2_5.3	5.3	525	5650	327	2790	21000	263	6950	201	4940	25800	
C 100 2_6.5	6.5	429	6150	291	1920	21800	215	7550	179	3950	27000	
C 100 2_7.1	7.1	396	6200	271	3100	22700	198	7650	167	5270	27900	
C 100 2_8.4	8.4	335	6700	248	1870	22800	168	8200	152	3970	28500	
C 100 2_9.0	9.0	309	6800	232	2950	23500	155	8350	142	5190	29200	
C 100 2_10.1	10.1	278	7100	217	1930	24100	139	8750	134	3900	29500	
C 100 2_10.9	10.9	256	7100	200	3240	25700	128	8750	124	5460	31600	
C 100 2_12.5	12.5	225	7650	190	1360	24900	112	9400	117	3260	30800	
C 100 2_13.5	13.5	208	7700	176	2600	26300	104	9500	109	4680	32100	
C 100 2_15.2	15.2	184	8100	164	1270	26600	92	10000	101	2680	32500	
C 100 2_16.5	16.5	170	8250	154	2320	27200	85	10150	95	4420	33600	
C 100 2_18.7	18.7	150	8200	136	1500	30800	75	10000	83	3600	38000	
C 100 2_20.2	20.2	138	8100	124	3047	32200	69	10000	76	5210	39600	
C 100 2_22.2	22.2	126	7500	104	3570	35800	63	9200	64	5960	44100	
C 100 2_24.1	24.1	116	8100	104	3620	35200	58	10000	64	5900	43300	
C 100 2_29.6	29.6	95	6900	72	6380	42400	47	8500	44	9220	52200	
C 100 3_34.3	34.3	82	10350	95	9790	33300	41	11700	54	13000	46400	
C 100 3_36.9	36.9	76	10650	91	10200	34500	38	11800	50	13100	48000	
C 100 3_42.9	42.9	65	11350	83	9640	33200	33	12000	44	13100	51200	
C 100 3_46.2	46.2	61	11700	80	10100	33100	30	12000	41	13300	53100	
C 100 3_53.3	53.3	53	12000	71	9450	36400	26.3	12000	36	13200	56900	
C 100 3_57.4	57.4	49	12000	66	10200	39500	24.4	12000	33	13400	59000	
C 100 3_64.5	64.5	43	12000	59	9950	44100	21.7	12000	29	13400	62300	
C 100 3_69.4	69.4	40	12000	54	10400	45900	20.2	12000	27	13500	64500	
C 100 3_79.4	79.4	35	12000	48	10300	49200	17.6	12000	24	13500	68600	
C 100 3_85.6	85.6	33	12000	44	10400	51100	16.4	12000	22	13600	70900	
C 100 3_92.7	92.7	30	12000	41	10400	53200	15.1	12000	20	13500	73500	
C 100 3_99.8	99.8	28.1	12000	38	10500	55200	14.0	12000	19.0	13600	75900	
C 100 3_111.9	111.9	25.0	12000	34	10400	58300	12.5	12000	16.9	13500	79800	
C 100 3_120.5	120.5	23.2	12000	31	10500	60400	11.6	12000	15.7	13700	82400	
C 100 3_139.7	139.7	20.0	11050	25	10600	67400	10.0	11050	12.5	13700	85000	
C 100 3_150.4	150.4	18.6	12000	25	10600	66900	9.3	12000	12.6	13700	85000	
C 100 4_162.1	162.1	17.3	12000	24	—	85000	8.6	12000	11.9	—	85000	
C 100 4_185.4	185.4	15.1	12000	21	—	85000	7.6	12000	10.4	—	85000	
C 100 4_199.6	199.6	14.0	12000	19.4	—	85000	7.0	12000	9.7	—	85000	
C 100 4_244.2	244.2	11.5	12000	15.8	—	85000	5.7	12000	7.9	—	85000	
C 100 4_263.0	263.0	10.6	12000	14.7	—	85000	5.3	12000	7.4	—	85000	
C 100 4_300.5	300.5	9.3	12000	12.9	—	85000	4.7	12000	6.4	—	85000	
C 100 4_323.6	323.6	8.7	12000	11.9	—	85000	4.3	12000	6.0	—	85000	
C 100 4_380.5	380.5	7.4	12000	10.2	—	85000	3.7	12000	5.1	—	85000	
C 100 4_409.8	409.8	6.8	12000	9.4	—	85000	3.4	12000	4.7	—	85000	
C 100 4_466.7	466.7	6.0	12000	8.3	—	85000	3.0	12000	4.1	—	85000	
C 100 4_502.6	502.6	5.6	12000	7.7	—	85000	2.8	12000	3.8	—	85000	
C 100 4_582.6	582.6	4.8	12000	6.6	—	85000	2.4	12000	3.3	—	85000	
C 100 4_627.4	627.4	4.5	12000	6.2	—	85000	2.2	12000	3.1	—	85000	
C 100 4_720.3	720.3	3.9	12000	5.4	—	85000	1.9	12000	2.7	—	85000	
C 100 4_775.7	775.7	3.6	12000	5.0	—	85000	1.8	12000	2.5	—	85000	
C 100 4_843.3	843.3	3.3	12000	4.6	—	85000	1.7	12000	2.3	—	85000	
C 100 4_908.2	908.2	3.1	12000	4.3	—	85000	1.5	12000	2.1	830	85000	
C 100 4_1004	1004	2.8	12000	3.9	—	85000	1.4	12000	1.9	—	85000	
C 100 4_1081	1081	2.6	12000	3.6	—	85000	1.3	12000	1.8	870	85000	

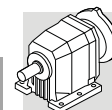
(-) Interpellare il ns. servizio tecnico comunicando i dati relativi al carico radiale (senso di rotazione, orientamento, posizione)
 (-) Contact our technical service department advising radial load data (rotation direction, load angle, offset)
 (-) Nehmen Sie bitte Kontakt mit unserem Applikationsdienst und Querkraftsdaten angeben (Drehrichtung, Orientierung, Anordnung)
 (-) Consulter notre service technique en donnant les détails concernant la charge radiale (sens de rotation, indexage, position)



	i	$n_1 = 900 \text{ min}^{-1}$					$n_1 = 500 \text{ min}^{-1}$					
		n_2 min^{-1}	M_{n2} Nm	P_{n1} kW	R_{n1} N	R_{n2} N	n_2 min^{-1}	M_{n2} Nm	P_{n1} kW	R_{n1} N	R_{n2} N	
C 100 2_4.9	4.9	183	7800	157	5310	28800	102	9300	104	6720	34400	143
C 100 2_5.3	5.3	169	7950	148	6680	29500	94	9450	98	9740	35200	
C 100 2_6.5	6.5	138	8600	131	5670	31000	77	10250	87	7540	37000	
C 100 2_7.1	7.1	127	8750	123	7050	31800	71	10450	81	10100	37800	
C 100 2_8.4	8.4	108	9350	111	5670	32600	60	10950	72	8530	40100	
C 100 2_9.0	9.0	99	9500	104	7080	33600	55	11350	69	10100	39900	
C 100 2_10.1	10.1	89	10000	98	5540	33600	50	10900	60	10600	44500	
C 100 2_10.9	10.9	82	10150	92	6980	34700	46	11500	58	11300	44300	
C 100 2_12.5	12.5	72	10700	85	3910	35400	40	10850	48	11700	49600	
C 100 2_13.5	13.5	67	10850	80	6440	36700	37	11450	47	12300	49500	
C 100 2_15.2	15.2	59	10800	70	5940	40800	33	10800	39	13000	54700	
C 100 2_16.5	16.5	55	11500	69	6320	39100	30	11500	38	13400	54500	
C 100 2_18.7	18.7	48	10900	58	6310	45100	26.8	10900	32	13400	59800	
C 100 2_20.2	20.2	45	11500	56	6890	45000	24.7	11500	31	14000	60100	
C 100 2_22.2	22.2	40	9850	44	9170	52200	22.5	9850	24	15000	67800	
C 100 2_24.1	24.1	37	10800	44	8930	51200	20.7	10800	25	15000	67200	
C 100 2_29.6	29.6	30	9100	31	12600	61400	16.9	9100	17.0	15000	78300	
C 100 3_34.3	34.3	26.2	11700	35	15000	57800	14.6	11700	19.2	15000	75500	
C 100 3_36.9	36.9	24.4	11800	32	15000	59600	13.5	11800	18.0	15000	77700	
C 100 3_42.9	42.9	21.0	12000	28	15000	63400	11.6	12000	15.7	15000	82300	
C 100 3_46.2	46.2	19.5	12000	26	15000	65600	10.8	12000	14.6	15000	84900	
C 100 3_53.3	53.3	16.9	12000	23	15000	69900	9.4	12000	12.7	15000	85000	
C 100 3_57.4	57.4	15.7	12000	21	15000	72300	8.7	12000	11.8	15000	85000	
C 100 3_64.5	64.5	14.0	12000	18.6	15000	76100	7.8	12000	10.5	15000	85000	
C 100 3_69.4	69.4	13.0	12000	17.5	15000	78600	7.2	12000	9.7	15000	85000	
C 100 3_79.4	79.4	11.3	12000	15.3	15000	83300	6.3	12000	8.5	15000	85000	
C 100 3_85.6	85.6	10.5	12000	14.2	15000	85000	5.8	12000	7.9	15000	85000	
C 100 3_92.7	92.7	9.7	12000	13.1	15000	85000	5.4	12000	7.3	15000	85000	
C 100 3_99.8	99.8	9.0	12000	12.2	15000	85000	5.0	12000	6.8	15000	85000	
C 100 3_111.9	111.9	8.0	12000	10.9	15000	85000	4.5	12000	6.0	15000	85000	
C 100 3_120.5	120.5	7.5	12000	10.1	15000	85000	4.1	12000	5.6	15000	85000	
C 100 3_139.7	139.7	6.4	11500	8.0	15000	85000	3.6	11050	4.5	15000	85000	
C 100 3_150.4	150.4	6.0	12000	8.1	15000	85000	3.3	12000	4.5	15000	85000	
C 100 4_162.1	162.1	5.6	12000	7.7	—	85000	3.1	12000	4.3	—	85000	
C 100 4_185.4	185.4	4.9	12000	6.7	—	85000	2.7	12000	3.7	920	85000	
C 100 4_199.6	199.6	4.5	12000	6.2	—	85000	2.5	12000	3.5	1430	85000	
C 100 4_244.2	244.2	3.7	12000	5.1	—	85000	2.0	12000	2.8	1490	85000	
C 100 4_263.0	263.0	3.4	12000	4.7	—	85000	1.9	12000	2.6	1950	85000	
C 100 4_300.5	300.5	3.0	12000	4.1	—	85000	1.7	12000	2.3	1840	85000	
C 100 4_323.6	323.6	2.8	12000	3.8	850	85000	1.5	12000	2.1	2280	85000	
C 100 4_380.5	380.5	2.4	12000	3.3	700	85000	1.3	12000	1.8	2130	85000	
C 100 4_409.8	409.8	2.2	12000	3.0	1120	85000	1.2	12000	1.7	2550	85000	
C 100 4_466.7	466.7	1.9	12000	2.7	910	85000	1.1	12000	1.5	2340	85000	
C 100 4_502.6	502.6	1.8	12000	2.5	1320	85000	1.0	12000	1.4	2740	85000	
C 100 4_582.6	582.6	1.5	12000	2.1	1100	85000	0.90	12000	1.2	2520	85000	
C 100 4_627.4	627.4	1.4	12000	2.0	1490	85000	0.80	12000	1.1	2910	85000	
C 100 4_720.3	720.3	1.2	12000	1.7	1270	85000	0.70	12000	1.0	2700	85000	
C 100 4_775.7	775.7	1.2	12000	1.6	1650	85000	0.60	12000	0.90	3070	85000	
C 100 4_843.3	843.3	1.1	12000	1.5	1360	85000	0.60	12000	0.80	2790	85000	
C 100 4_908.2	908.2	1.0	12000	1.4	1730	85000	0.60	12000	0.80	3160	85000	
C 100 4_1004	1004	0.90	12000	1.2	1400	85000	0.50	12000	0.70	2830	85000	
C 100 4_1081	1081	0.90	12000	1.1	1770	85000	0.50	12000	0.60	3170	85000	

(-) Interpellare il ns. servizio tecnico comunicando i dati relativi al carico radiale (senso di rotazione, orientamento, posizione)
 (-) Contact our technical service department advising radial load data (rotation direction, load angle, offset)
 (-) Nehmen Sie bitte Kontakt mit unserem Applikationsdienst und Querkraftsdaten angeben (Drehrichtung, Orientierung, Anordnung)
 (-) Consulter notre service technique en donnant les détails concernant la charge radiale (sens de rotation, indexage, position)

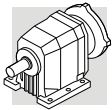

C 05...M

28 - DIMENSIONI

28 - DIMENSIONS

28 - ABMESSUNGEN

28 - DIMENSIONS

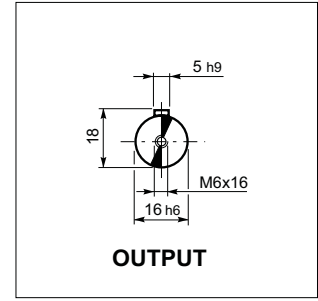
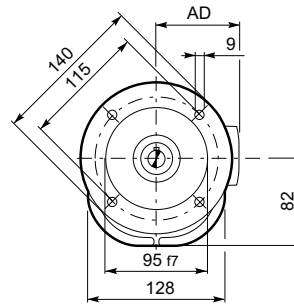
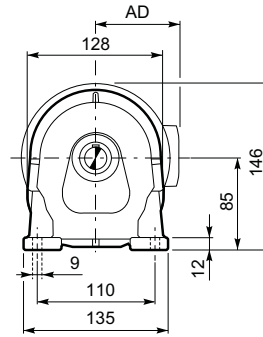
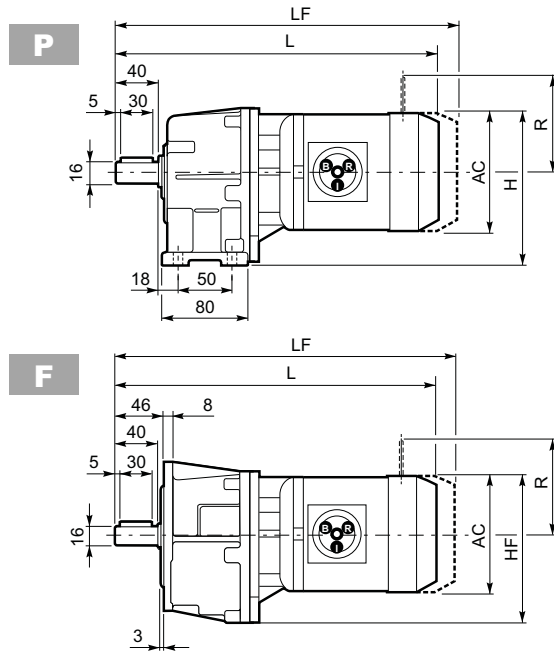

C 05														
			M...FD M...FA							M...FD		M...FA		
			AC	H	HF	L	AD		LF		R	AD	R	AD
C 05 2	S0	M0	110	140	137	287	91	7	—	—	—	—	—	—
C 05 2	S05	M05	121	145.5	142.5	332	95	8	398	10	96	119	116	95
C 05 2	S1	M1S	138	154	151	337	108	9	400	12	103	132	124	108
C 05 2	S1	M1L	138	154	151	360.5	108	11	423	13	103	132	124	108

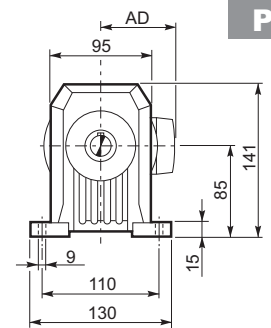
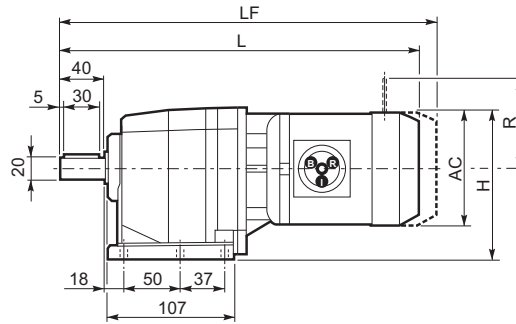
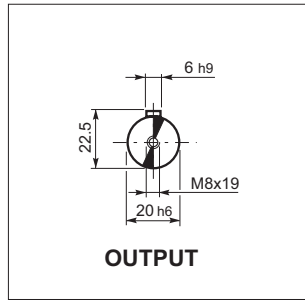
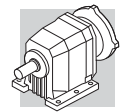

P

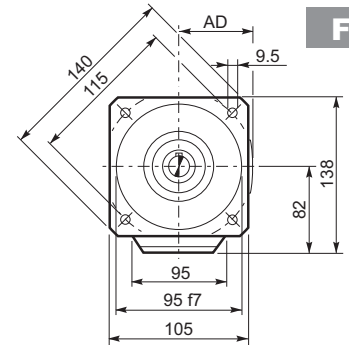
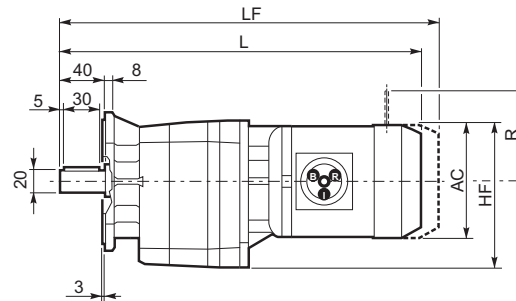

F

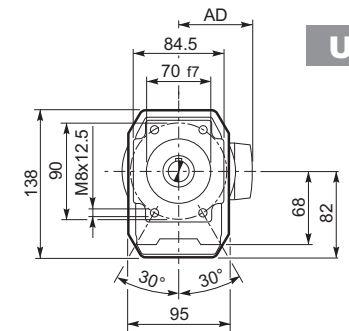
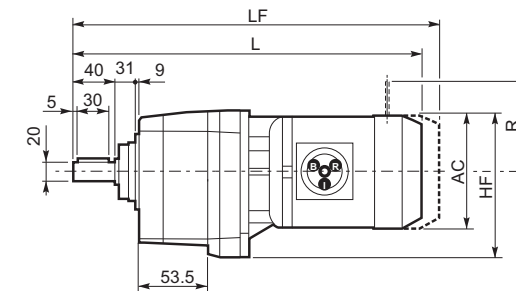

U

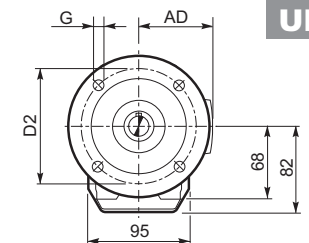
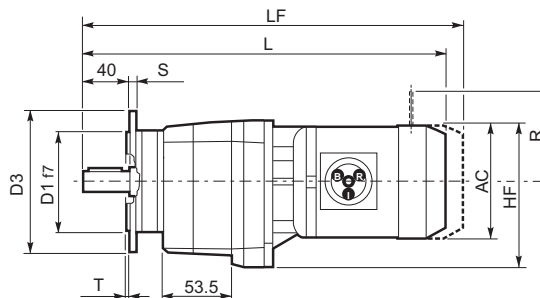

UF

C 11 2 U						
	D1	D2	D3	G	T	S
FA	80	100	120	7	3	8
FB	95	115	140	9	3	10
FC	110	130	160	9	3	10

C 11														
			M...FD							M...FD		M...FA		
			AC	H	HF	L	AD	Kg	LF	Kg	R	AD	R	AD
C 11 2	S05	M05	121	145.5	142.5	370.5	95	9	436.5	10	96	119	116	95
C 11 2	S1	M1S	138	154	151	375.5	108	10	438.5	12	103	132	124	108
C 11 2	S1	M1L	138	154	151	404.5	108	11	460.5	13	103	132	124	108
C 11 2	S2	M2S	156	163	160	422.5	119	15	498.5	18	129	143	134	119
C 11 2	S3	M3S	195	182.5	179.5	471.5	142	20	567.5	25	160	155	160	142
C 11 2	S3	M3L	195	182.5	179.5	503.5	142	22	594.5	27	160	155	160	142

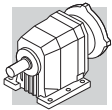

C 11...P(IEC)

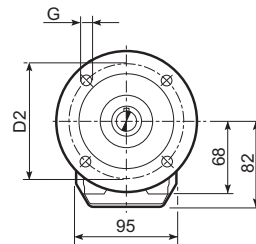
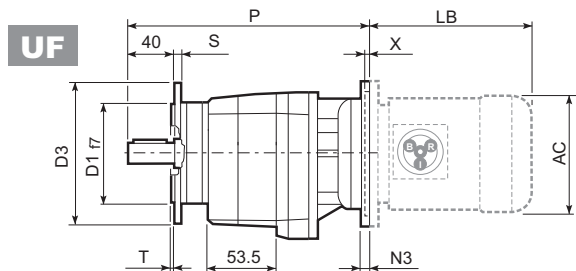
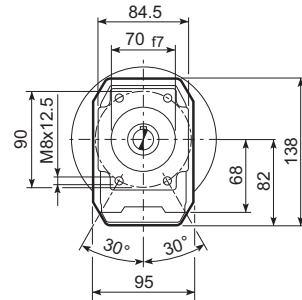
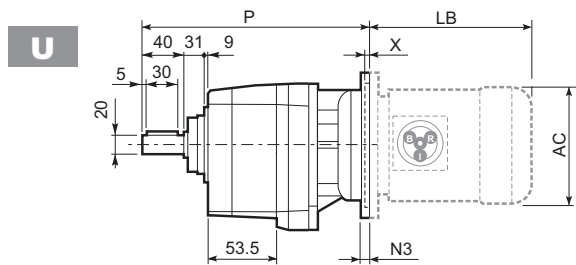
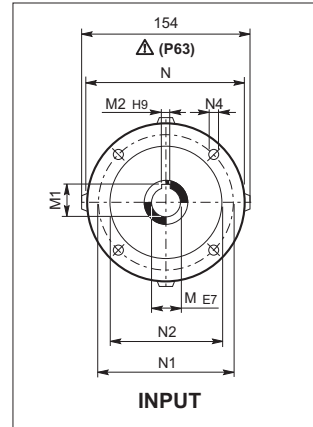
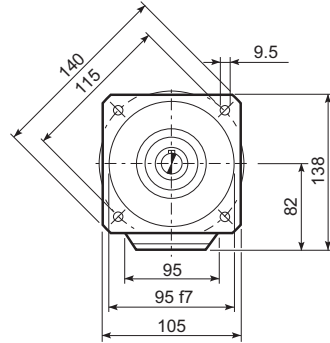
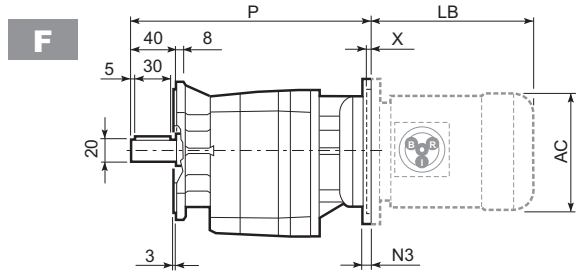
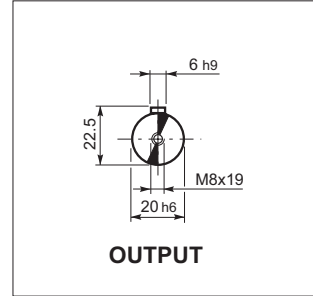
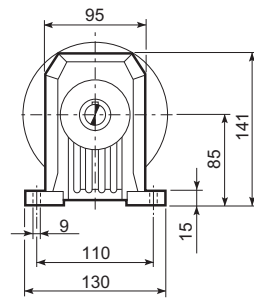
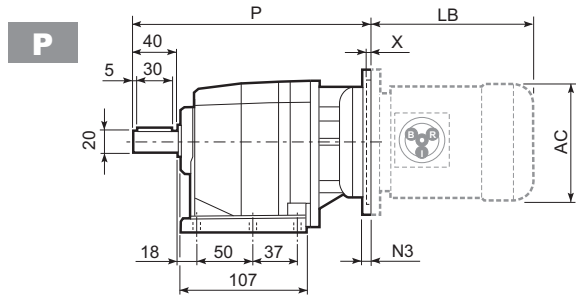

C 11 2 U						
	D1	D2	D3	G	T	S
FA	80	100	120	7	3	8
FB	95	115	140	9	3	10
FC	110	130	160	9	3	10

C 11														BN...		BN...FD BN...FA	
		M	M1	M2	N	N1	N2	N3	N4	X	P			LB	AC	LB	AC
C 11 2	P63	11	12.8	4	140	115	95	—	M8x19	4	244.5	6	BN 63	184	121	249	121
C 11 2	P71	14	16.3	5	160	130	110	—	M8x16	4.5	244.5	6	BN 71	219	138	280	138
C 11 2	P80	19	21.8	6	200	165	130	—	M10x12	4	264	7	BN 80	234	156	306	156
C 11 2	P90	24	27.3	8	200	165	130	—	M10x12	4	264	7	BN 90	276	176	359	176
C 11 2	P100	28	31.3	8	250	215	180	—	M12x16	4.5	274	11	BN 100	307	195	398	195
C 11 2	P112	28	31.3	8	250	215	180	—	M12x16	4.5	274	11	BN 112	325	219	424	219

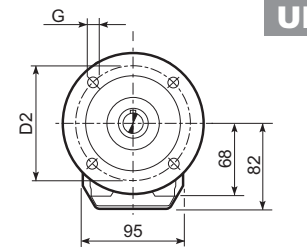
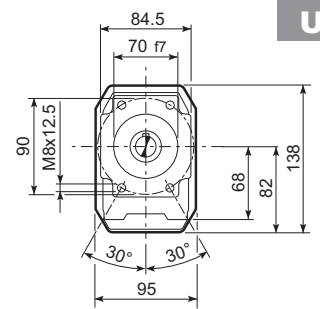
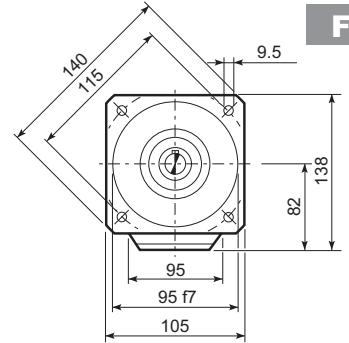
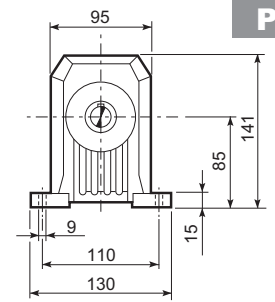
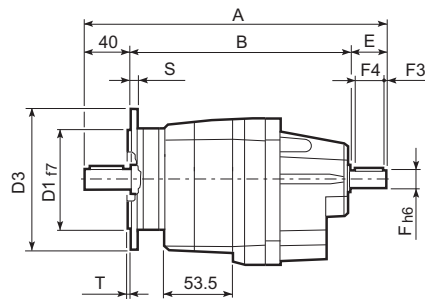
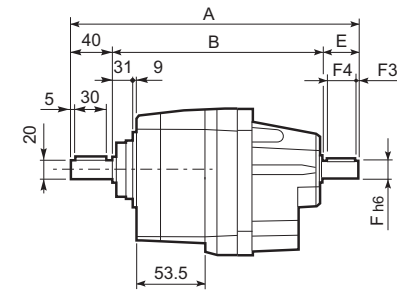
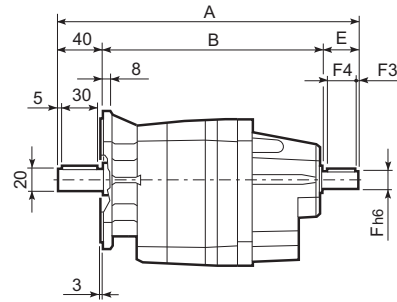
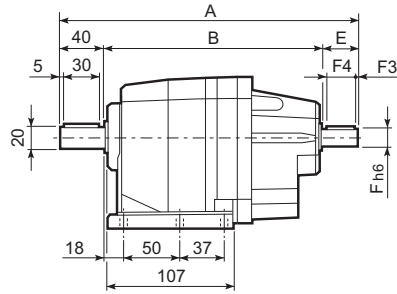
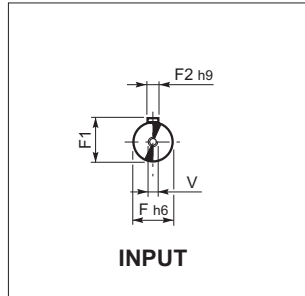
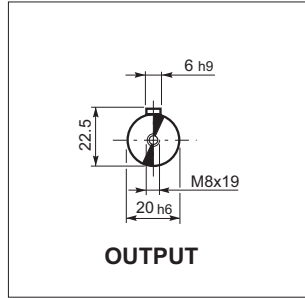
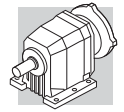

C 11 2 U						
	D1	D2	D3	G	T	S
FA	80	100	120	7	3	8
FB	95	115	140	9	3	10
FC	110	130	160	9	3	10

C 11											
		A	B	E	F	F1	F2	F3	F4	V	Kg
		251.5	171.5	40	16	18	5	2.5	35	M6x16	7.8

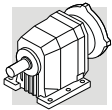

C 21...M

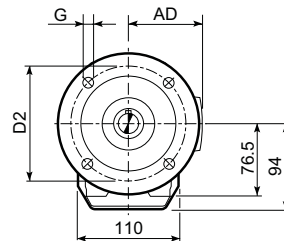
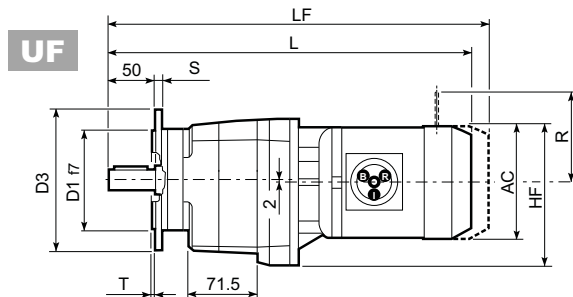
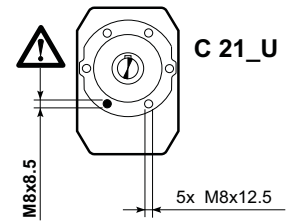
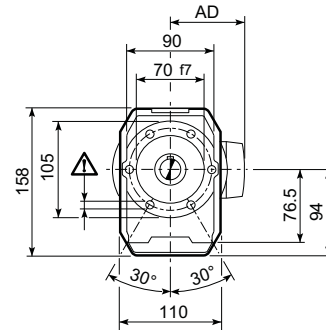
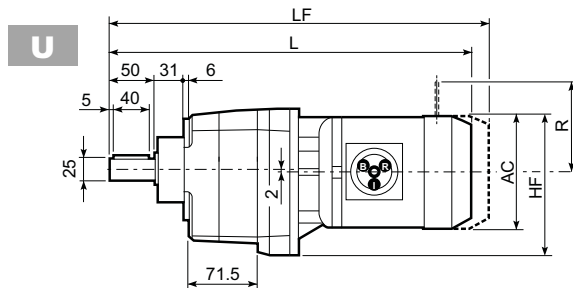
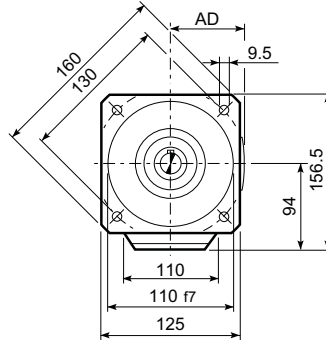
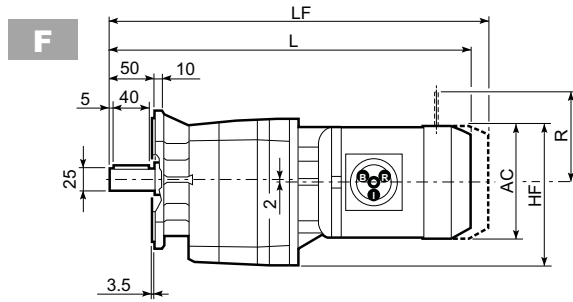
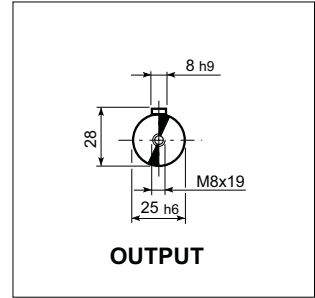
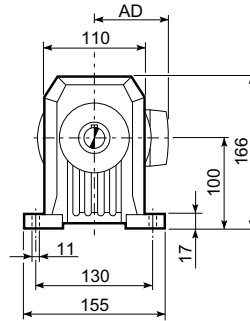
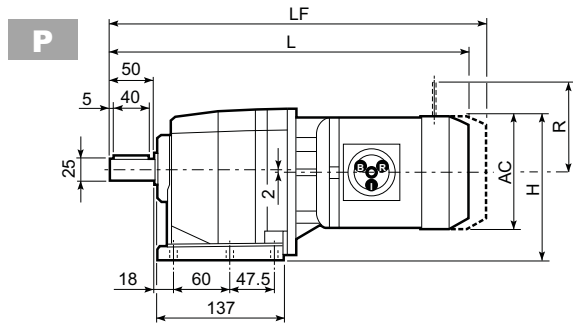

C 21_U

	D1	D2	D3	G	T	S
FA	95	115	140	9	3	10
FB	110	130	160	9	3	10
FC	130	165	200	11	3.5	11

C 21															
Motor Icon	Type	Series	M...FD							M...FD		M...FA			
			AC	H	HF	L	AD	Kg	LF	Kg	R	AD	R	AD	
	C 21 2	S1	M1S	138	169	163	404	108	10	467	13	103	132	124	108
	C 21 2	S1	M1L	138	169	163	428	108	11	489	14	103	132	124	108
	C 21 2	S2	M2S	156	178	170	456	119	16	527	19	129	143	134	119
	C 21 2	S3	M3S	195	197.5	191.5	500	142	21	596	26	160	155	160	142
	C 21 2	S3	M3L	195	197.5	191.5	532	142	27	623	32	160	155	160	142
	C 21 3	S05	M05	121	160.5	154.5	454.5	95	11	520.5	12	96	119	116	95
	C 21 3	S1	M1S	138	169	163	459.5	108	12	522.5	14	103	132	124	108
	C 21 3	S1	M1L	138	169	163	483.5	108	13	544.5	15	103	132	124	108

C 21...P(IEC)

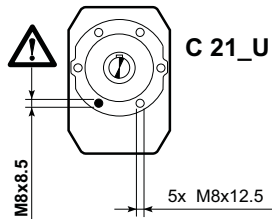
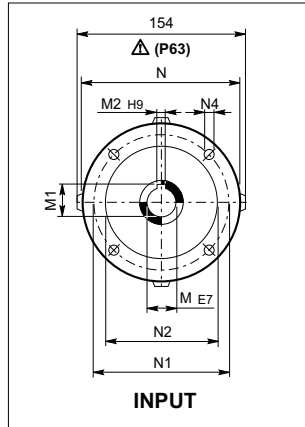
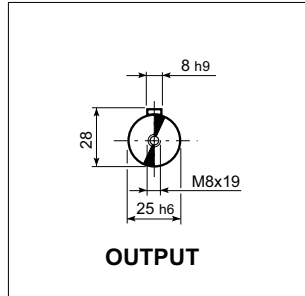
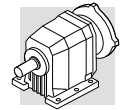

C 21_U						
	D1	D2	D3	G	T	S
FA	95	115	140	9	3	10
FB	110	130	160	9	3	10
FC	130	165	200	11	3.5	11

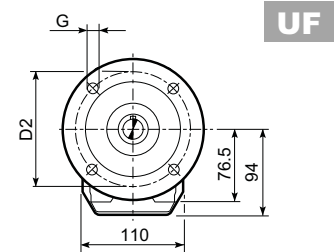
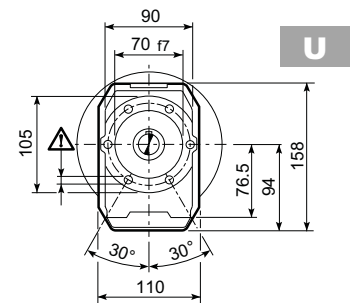
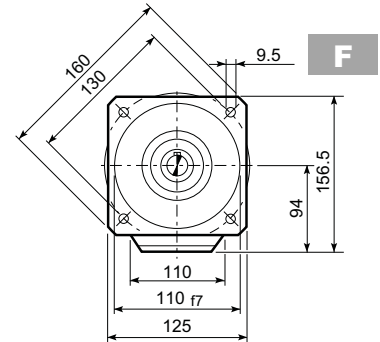
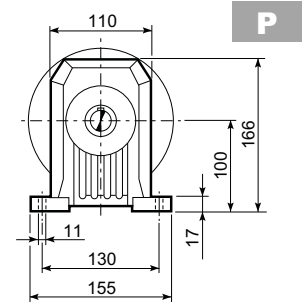
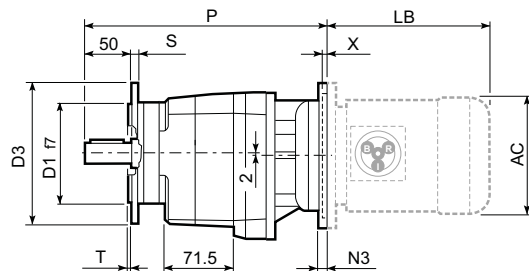
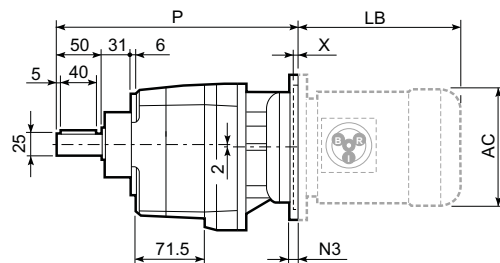
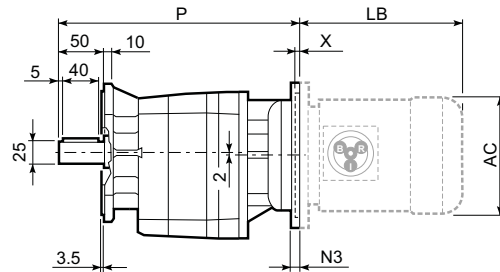
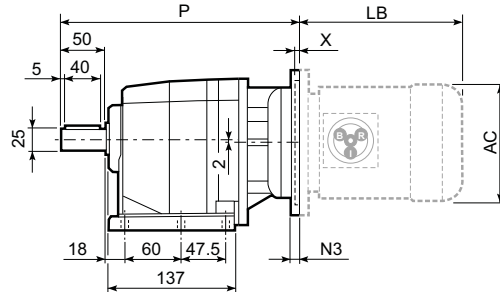

C 21													BN...		BN...FD BN...FA		
		M	M1	M2	N	N1	N2	N3	N4	X	P	Kg		LB	AC	LB	AC
C 21 2	P63	11	12.8	4	140	115	95	—	M8x19	4	273	7		184	121	249	121
C 21 2	P71	14	16.3	5	160	130	110	—	M8x16	4.5	273	7		219	138	280	138
C 21 2	P80	19	21.8	6	200	165	130	—	M10x12	4	292.5	8		234	156	306	156
C 21 2	P90	24	27.3	8	200	165	130	—	M10x12	4	292.5	8		276	176	359	176
C 21 2	P100	28	31.3	8	250	215	180	—	M12x16	4.5	302.5	12		307	195	398	195
C 21 2	P112	28	31.3	8	250	215	180	—	M12x16	4.5	302.5	12		325	219	424	219
C 21 3	P63	11	12.8	4	140	115	95	—	M8x19	4	328.5	8		184	121	249	121
C 21 3	P71	14	16.3	5	160	130	110	—	M8x16	4.5	328.5	8		219	138	280	138
C 21 3	P80	19	21.8	6	200	165	130	—	M10x12	4	348	9		234	156	306	156
C 21 3	P90	24	27.3	8	200	165	130	—	M10x12	4	348	9		276	176	359	176
C 21 3	P100	28	31.3	8	250	215	180	—	M12x16	4.5	358	13		307	195	398	195
C 21 3	P112	28	31.3	8	250	215	180	—	M12x16	4.5	358	13		325	219	424	219

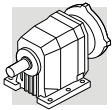

C 21...HS

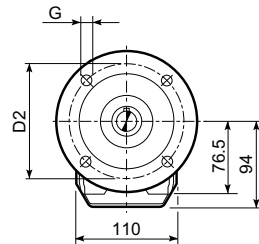
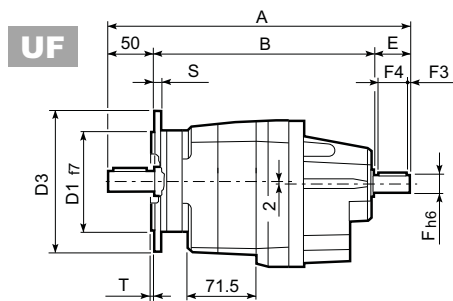
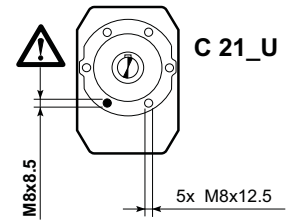
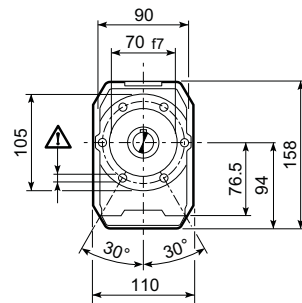
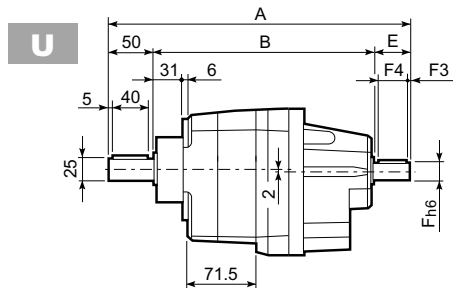
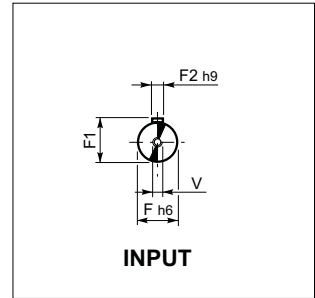
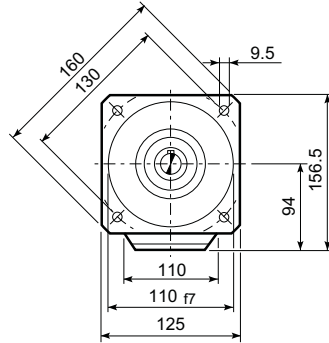
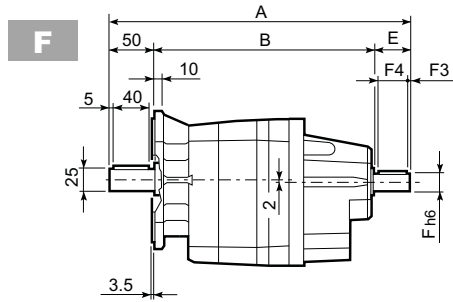
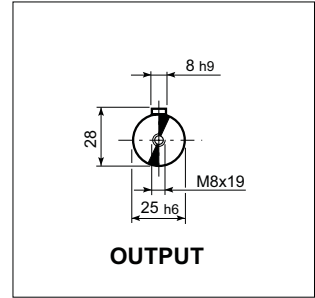
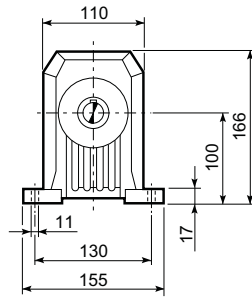
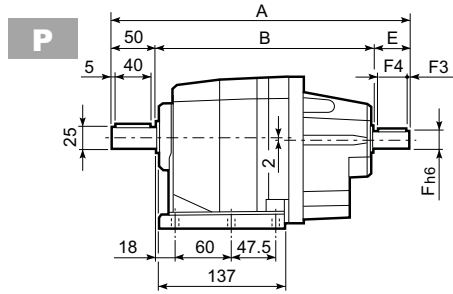

C 21_U

	D1	D2	D3	G	T	S
FA	95	115	140	9	3	10
FB	110	130	160	9	3	10
FC	130	165	200	11	3.5	11

C 21											
		A	B	E	F	F1	F2	F3	F4	V	Kg
C 21 2	HS	323	233	40	19	21.5	6	2.5	35	M6x16	7.2
C 21 3		335.5	245.5	40	16	18	6	2.5	36	M6x16	7.5

C 31...M

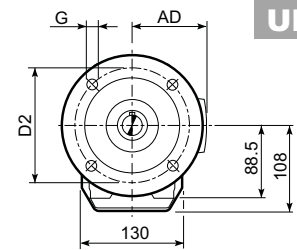
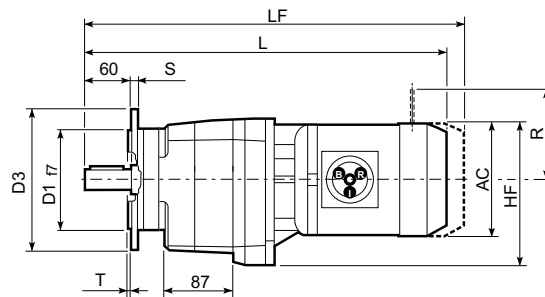
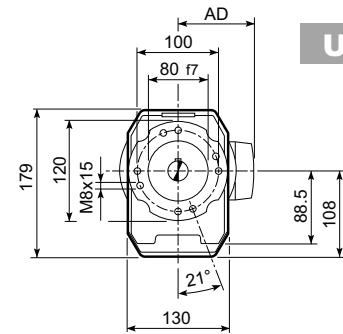
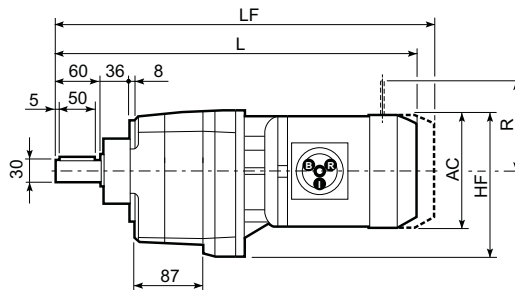
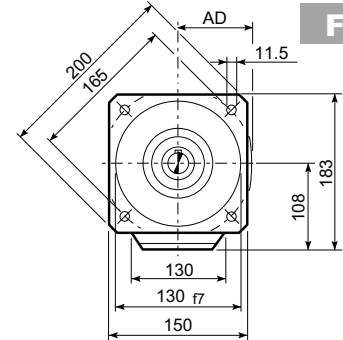
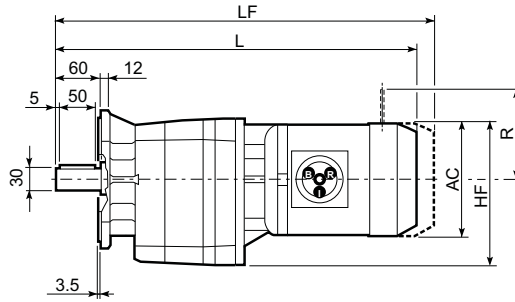
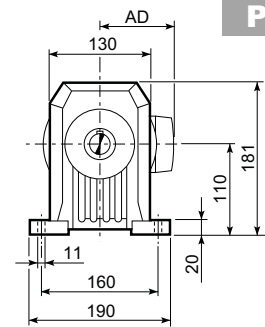
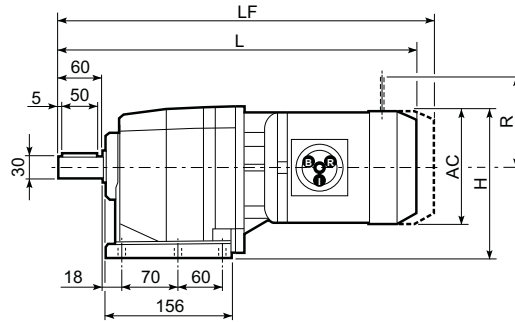
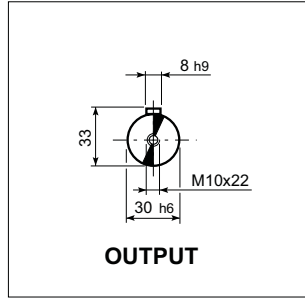
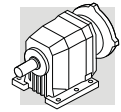

C 31_U						
	D1	D2	D3	G	T	S
FA	110	130	160	9	3	10
FB	130	165	200	11	3.5	11
FC	180	215	250	14	4	13

C 31														
			AC	H	HF	L	AD	Kg	M...FD M...FA		M...FD		M...FA	
									LF	Kg	R	AD	R	AD
C 31 2	S1	M1S	138	179	177	438.5	108	13	501.5	15	103	132	124	108
C 31 2	S1	M1L	138	179	177	462.5	108	14	523.5	16	103	132	124	108
C 31 2	S2	M2S	156	188	186	490.5	119	18	561.5	21	129	143	134	119
C 31 2	S3	M3S	195	207.5	205.5	534.5	142	23	630.5	28	160	155	160	142
C 31 2	S3	M3L	195	207.5	205.5	566.5	142	32	657.5	37	160	155	160	142
C 31 3	S05	M05	121	170.5	168.5	491	95	13	557	15	96	119	116	95
C 31 3	S1	M1S	138	179	177	496	108	14	559	16	103	132	124	108
C 31 3	S1	M1L	138	179	177	520	108	15	581	17	103	132	124	108
C 31 3	S2	M2S	156	188	186	548	119	18	619	21	129	143	134	119

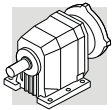

C 31...P(IEC)

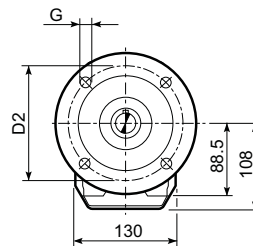
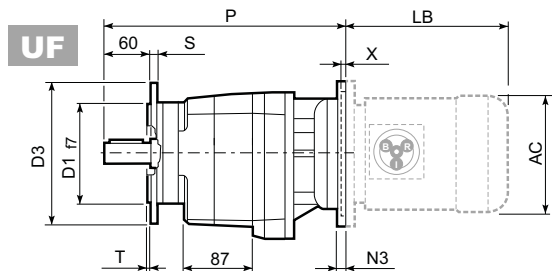
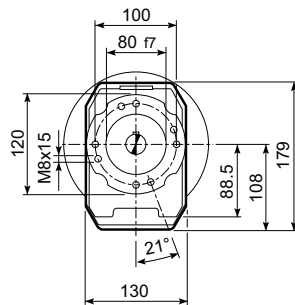
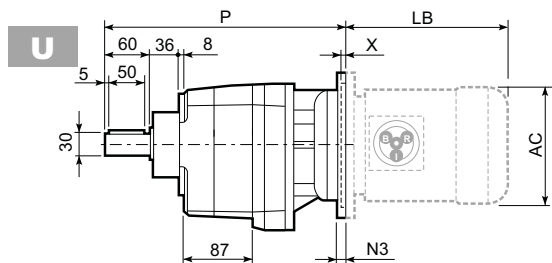
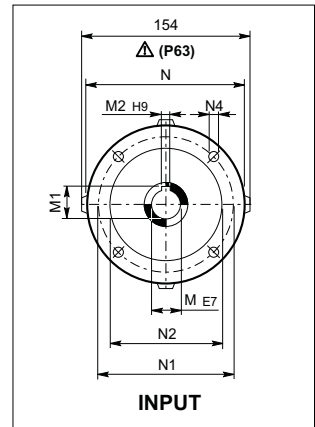
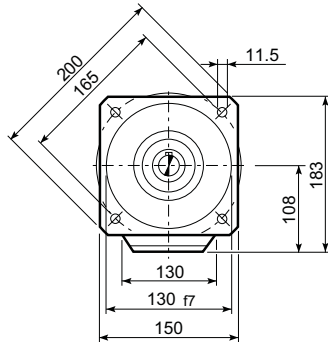
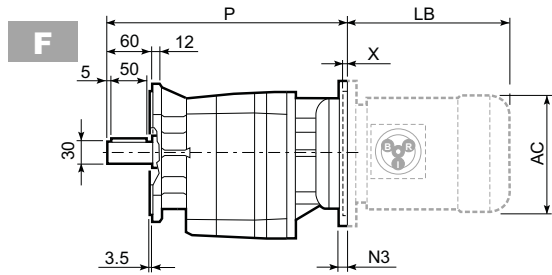
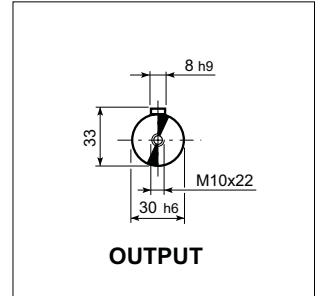
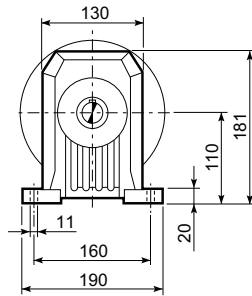
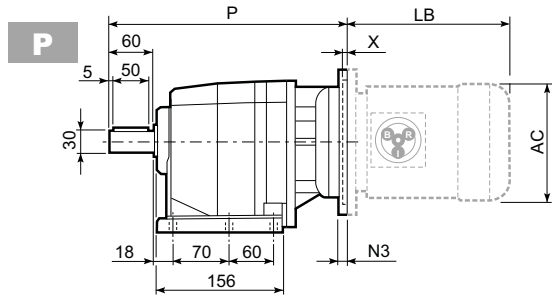

C 31_U						
	D1	D2	D3	G	T	S
FA	110	130	160	9	3	10
FB	130	165	200	11	3.5	11
FC	180	215	250	14	4	13

C 31													BN...		BN...FD BN...FA			
		M	M1	M2	N	N1	N2	N3	N4	X	P			LB	AC	LB	AC	
C 31 2	P63	11	12.8	4	140	115	95	—	M8x19	4	307.5	9		BN 63	184	121	249	121
C 31 2	P71	14	16.3	5	160	130	110	—	M8x16	4.5	307.5	9		BN 71	219	138	280	138
C 31 2	P80	19	21.8	6	200	165	130	—	M10x12	4	327	10		BN 80	234	156	306	156
C 31 2	P90	24	27.3	8	200	165	130	—	M10x12	4	327	10		BN 90	276	176	359	176
C 31 2	P100	28	31.3	8	250	215	180	—	M12x16	4.5	337	14		BN 100	307	195	398	195
C 31 2	P112	28	31.3	8	250	215	180	—	M12x16	4.5	337	14		BN 112	325	219	424	219
C 31 3	P63	11	12.8	4	140	115	95	—	M8x19	4	365	10		BN 63	184	121	249	121
C 31 3	P71	14	16.3	5	160	130	110	—	M8x16	4.5	365	10		BN 71	219	138	280	138
C 31 3	P80	19	21.8	6	200	165	130	—	M10x12	4	384.5	11		BN 80	234	156	306	156
C 31 3	P90	24	27.3	8	200	165	130	—	M10x12	4	384.5	11		BN 90	276	176	359	176
C 31 3	P100	28	31.3	8	250	215	180	—	M12x16	4.5	394.5	15		BN 100	307	195	398	195
C 31 3	P112	28	31.3	8	250	215	180	—	M12x16	4.5	394.5	15		BN 112	325	219	424	219

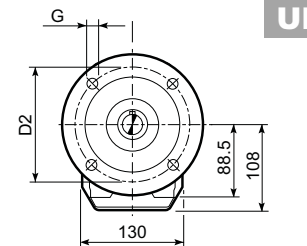
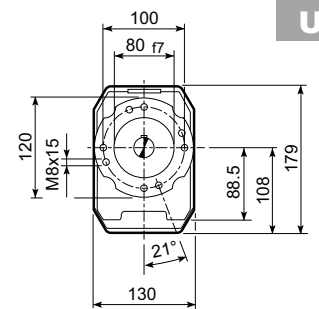
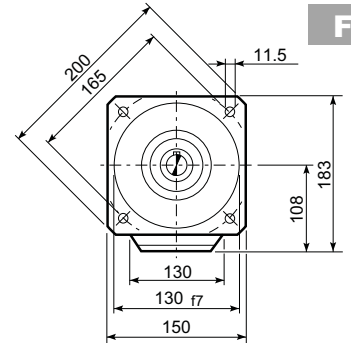
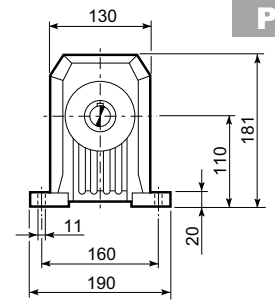
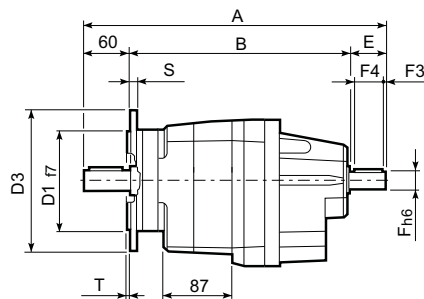
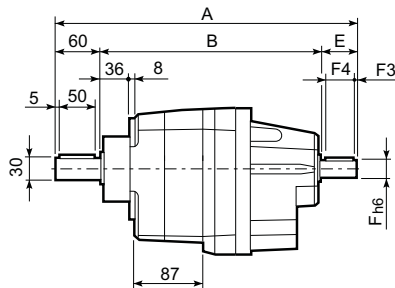
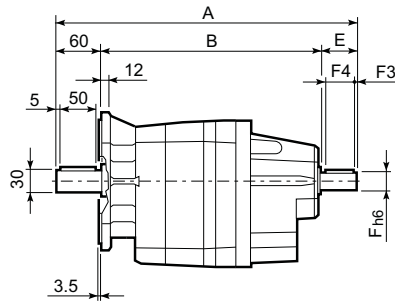
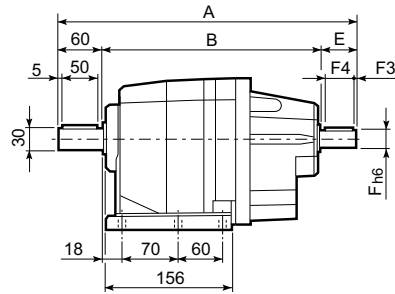
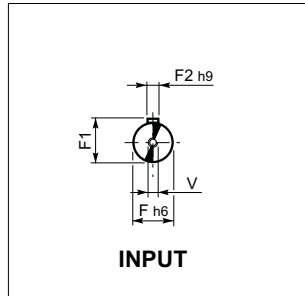
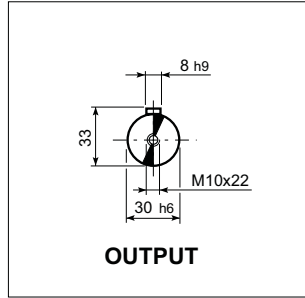
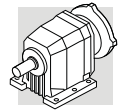

C 31_U						
	D1	D2	D3	G	T	S
FA	110	130	160	9	3	10
FB	130	165	200	11	3.5	11
FC	180	215	250	14	4	13

C 31											
		A	B	E	F	F1	F2	F3	F4	V	Kg
C 31 2	HS	357.5	257.5	40	19	21.5	6	2.5	35	M6x16	11.1
C 31 3		372	272	40	16	18	5	2.5	36	M6x16	10.6

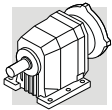

C 35...M

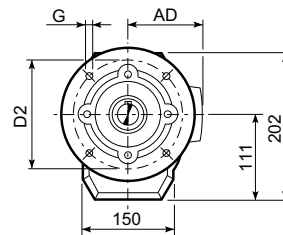
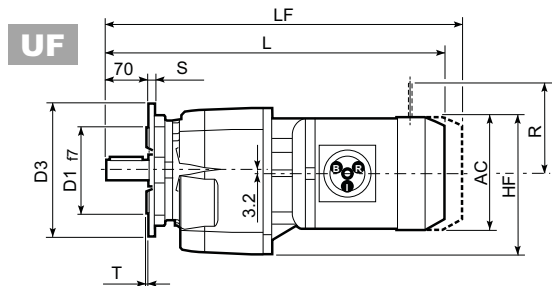
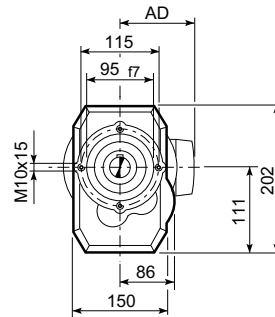
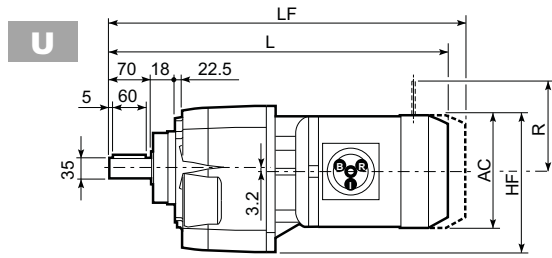
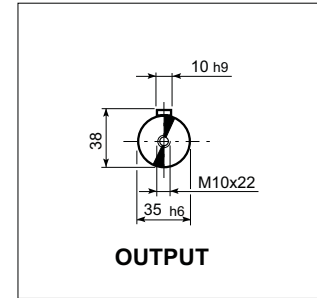
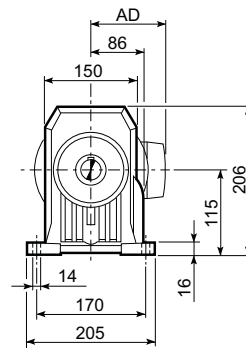
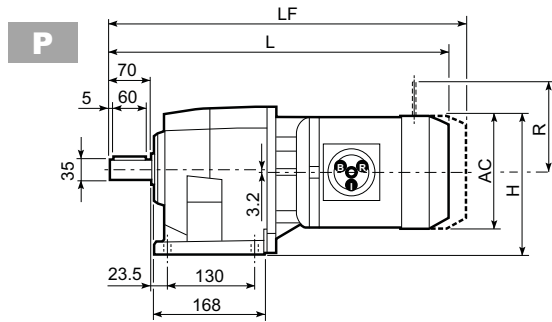

C 35 U						
	D1	D2	D3	G	T	S
FA	130	165	200	11	3.5	11
FB	180	215	250	14	4	14

C 35														
			AC	H	HF	L	AD	Kg	M...FD		M...FD		M...FA	
									LF	Kg	R	AD	R	AD
C 35 2/3	S1	M1S	138	184	177	457	108	20	520	20	103	132	124	108
C 35 2/3	S1	M1L	138	184	177	481	108	20	542	21	103	132	124	108
C 35 2/3	S2	M2S	156	193	186	509	119	23	580	27	129	143	134	119
C 35 2/3	S3	M3S	195	212.5	205.5	553	142	28	649	33	160	155	160	142
C 35 2/3	S3	M3L	195	212.5	205.5	585	142	37	676	42	160	155	160	142
C 35 4	S05	M05	121	175.5	168.5	509.5	95	19	575.5	20	96	119	116	95
C 35 4	S1	M1S	138	184	177	514.5	108	21	577.5	21	103	132	124	108
C 35 4	S1	M1L	138	184	177	538.5	108	21	599.5	22	103	132	124	108
C 35 4	S2	M2S	156	193	186	566.5	119	24	637.5	28	129	143	134	119
C 35 4	S3	M3S	195	212.5	205.5	610.5	142	29	706.5	34	160	155	160	142
C 35 4	S3	M3L	195	212.5	205.5	642.5	142	38	733.5	43	160	155	160	142

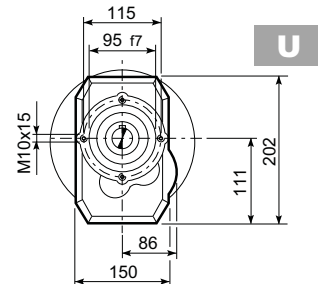
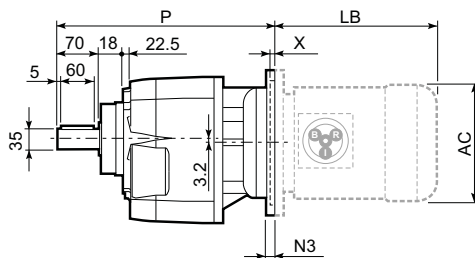
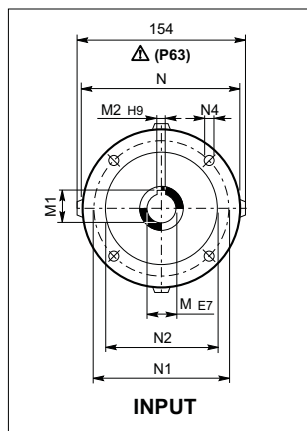
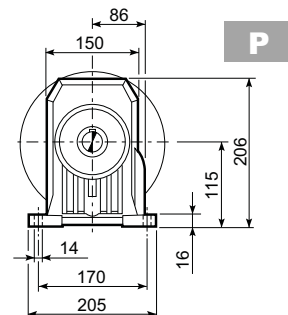
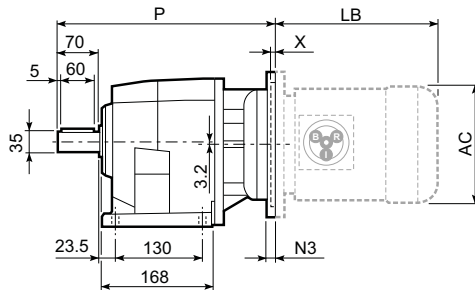
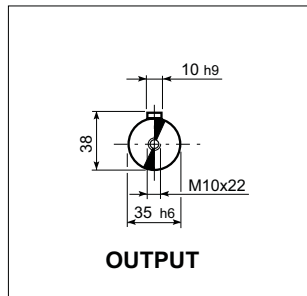
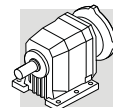

C 35 U						
	D1	D2	D3	G	T	S
FA	130	165	200	11	3.5	11
FB	180	215	250	14	4	14

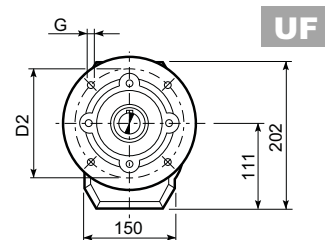
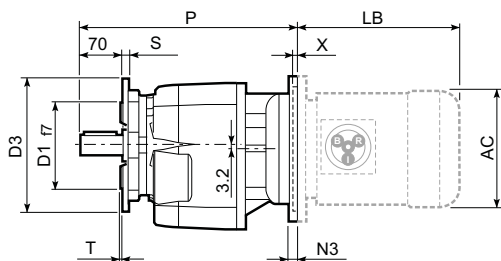

C 35													BN...		BN...FD BN...FA		
		M	M1	M2	N	N1	N2	N3	N4	X	P	kg		LB	AC	LB	AC
C 35 2/3	P63	11	12.8	4	140	115	95	—	M8x19	4	326	17	BN 63	184	121	249	121
C 35 2/3	P71	14	16.3	5	160	130	110	—	M8x16	4.5	326	17	BN 71	219	138	280	138
C 35 2/3	P80	19	21.8	6	200	165	130	—	M10x12	4	345.5	18	BN 80	234	156	306	156
C 35 2/3	P90	24	27.3	8	200	165	130	—	M10x12	4	345.5	18	BN 90	276	176	359	176
C 35 2/3	P100	28	31.3	8	250	215	180	—	M12x16	4.5	355.5	22	BN 100	307	195	398	195
C 35 2/3	P112	28	31.3	8	250	215	180	—	M12x16	4.5	355.5	22	BN 112	325	219	424	219
C 35 4	P63	11	12.8	4	140	115	95	—	M8x19	4	383.5	20	BN 63	184	121	249	121
C 35 4	P71	14	16.3	5	160	130	110	—	M8x16	4.5	383.5	20	BN 71	219	138	280	138
C 35 4	P80	19	21.8	6	200	165	130	—	M10x12	4	403	21	BN 80	234	156	306	156
C 35 4	P90	24	27.3	8	200	165	130	—	M10x12	4	403	21	BN 90	276	176	359	176
C 35 4	P100	28	31.3	8	250	215	180	—	M12x16	4.5	413	25	BN 100	307	195	398	195
C 35 4	P112	28	31.3	8	250	215	180	—	M12x16	4.5	413	25	BN 112	325	219	424	219

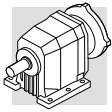

C 35...HS

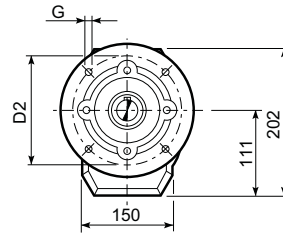
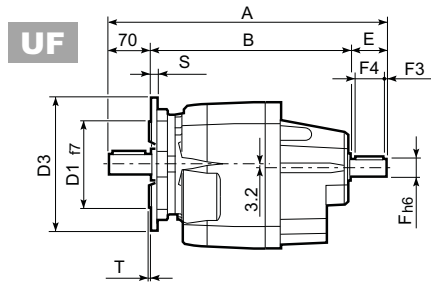
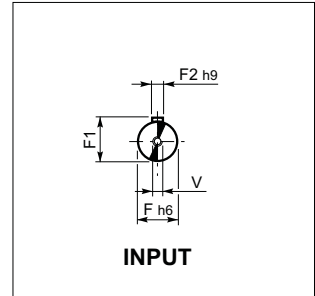
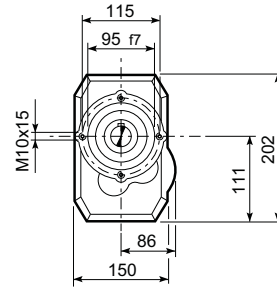
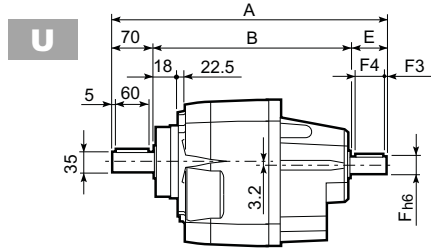
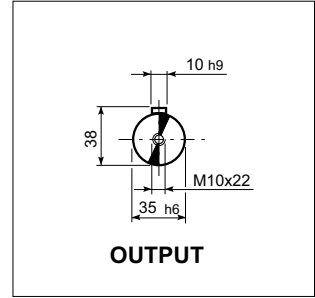
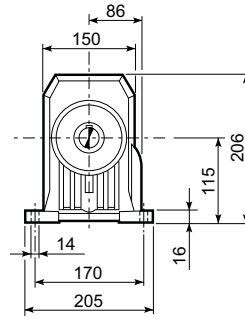
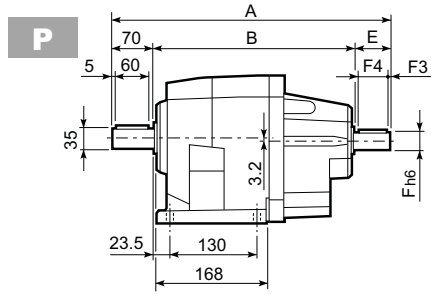

C 35 U						
	D1	D2	D3	G	T	S
FA	130	165	200	11	3.5	11
FB	180	215	250	14	4	14

C 35											
		A	B	E	F	F1	F2	F3	F4	V	Kg
C 35 2	HS	415.5	295.5	50	24	27	8	2.5	45	M8x19	25.5
C 35 3		415.5	295.5	50	24	27	8	2.5	45	M8x19	25.5
C 35 4		390.5	280.5	40	16	18	5	2.5	36	M6x16	26.5

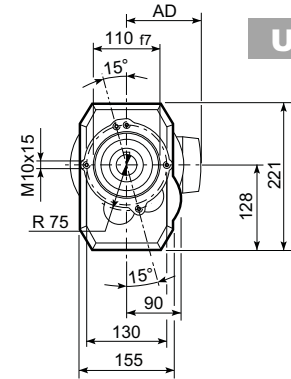
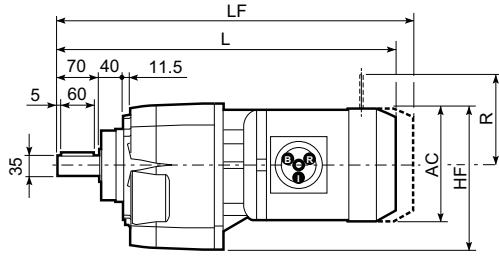
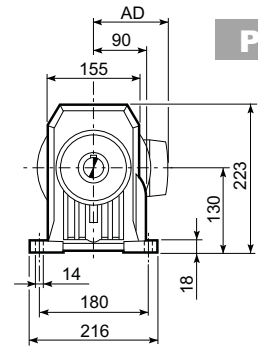
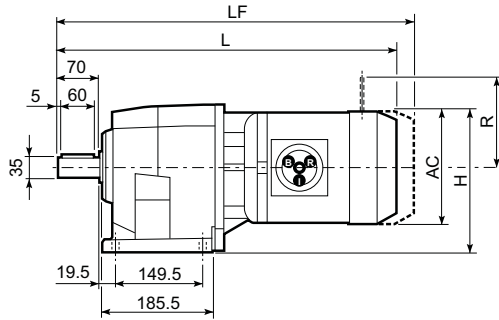
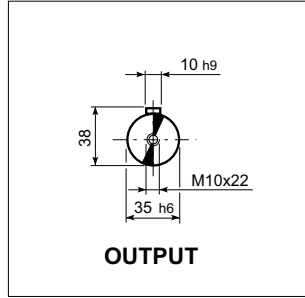
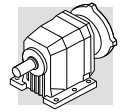

C 41 U						
	D1	D2	D3	G	T	S
FA	130	165	200	11	3.5	11
FB	180	215	250	14	4	13

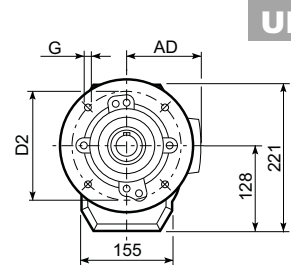
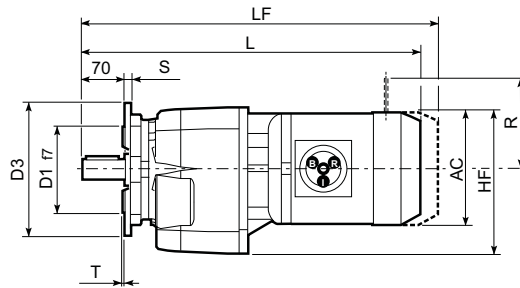

C 41																	
									M...FD M...FA		M...FD		M...FA				
			AC	H	HF	L	AD		LF		R	AD	R	AD			
			C 41 2/3	S1	M1S	138	199	197	467.5	108	25	530.5	27	103	132	124	108
			C 41 2/3	S1	M1L	138	199	197	491.5	108	25	552.5	28	103	132	124	108
			C 41 2/3	S2	M2S	156	208	206	519.5	119	31	590.5	34	129	143	134	119
			C 41 2/3	S3	M3S	195	227.5	225.5	563.5	142	36	659.5	41	160	155	160	142
			C 41 2/3	S3	M3L	195	227.5	225.5	595.5	142	45	686.5	50	160	155	160	142
			C 41 2/3	S4	M4	258	259	257	703.5	193	71	812.5	83	226	193	217	193
			C 41 4	S05	M05	231	245.5	243.5	524	95	27	590	28	96	119	116	95
			C 41 4	S1	M1S	138	199	197	529	108	28	592	30	103	132	124	108
			C 41 4	S1	M1L	138	199	197	553	108	28	614	31	103	132	124	108
			C 41 4	S2	M2S	156	208	206	581	119	34	652	37	129	143	134	119
			C 41 4	S3	M3S	195	227.5	225.5	625	142	39	721	44	160	155	160	142
			C 41 4	S3	M3L	195	227.5	225.5	657	142	48	748	53	160	155	160	142

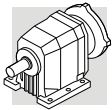

C 41...P(IEC)

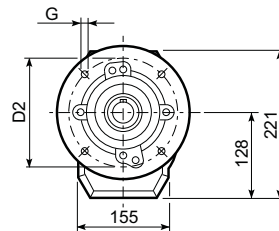
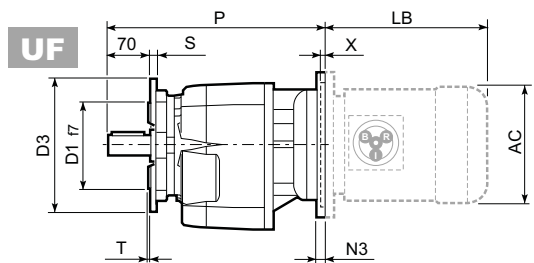
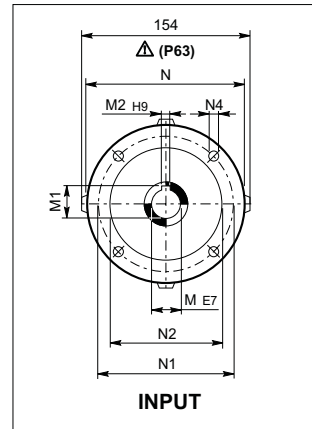
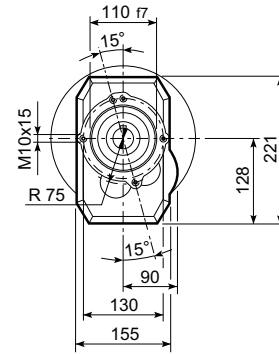
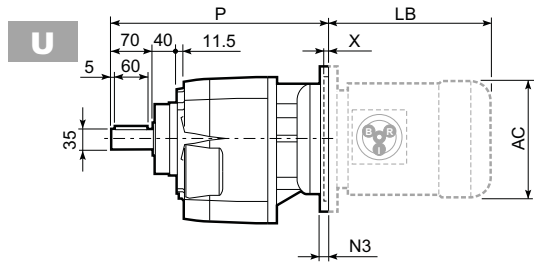
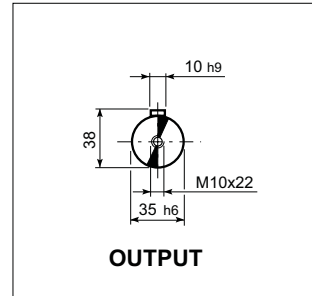
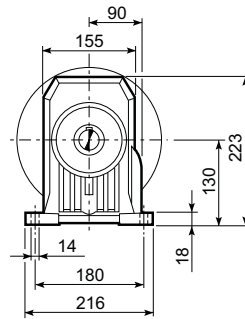
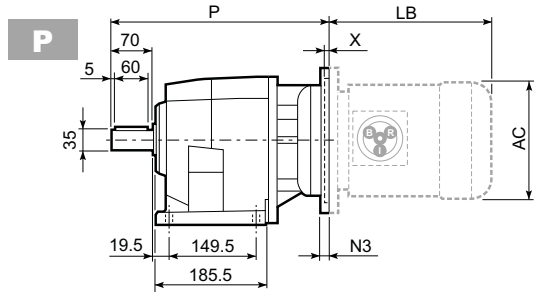

		C 41 U					
		D1	D2	D3	G	T	S
FA		130	165	200	11	3.5	11
FB		180	215	250	14	4	13

C 41													BN...		BN...FD BN...FA		
		M	M1	M2	N	N1	N2	N3	N4	X	P		LB	AC	LB	AC	
C 41 2/3	P63	11	12.8	4	140	115	95	—	M8x19	4	336.5	27	BN 63	184	121	249	121
C 41 2/3	P71	14	16.3	5	160	130	110	—	M8x16	4.5	336.5	28	BN 71	219	138	280	138
C 41 2/3	P80	19	21.8	6	200	165	130	—	M10x12	4	356	29	BN 80	234	156	306	156
C 41 2/3	P90	24	27.3	8	200	165	130	—	M10x12	4	356	29	BN 90	276	176	359	176
C 41 2/3	P100	28	31.3	8	250	215	180	—	M12x16	4.5	366	33	BN 100	307	195	398	195
C 41 2/3	P112	28	31.3	8	250	215	180	—	M12x16	4.5	366	33	BN 112	325	219	424	219
C 41 2/3	P132	38	41.3	10	300	265	230	16	14	5	402.5	35	BN 132	413	258	523	258
C 41 4	P63	11	12.8	4	140	115	95	—	M8x19	4	395	30	BN 63	184	121	249	121
C 41 4	P71	14	16.3	5	160	130	110	—	M8x16	4.5	395	31	BN 71	219	138	280	138
C 41 4	P80	19	21.8	6	200	165	130	—	M10x12	4	414.5	32	BN 80	234	156	306	156
C 41 4	P90	24	27.3	8	200	165	130	—	M10x12	4	414.5	32	BN 90	276	176	359	176
C 41 4	P100	28	31.3	8	250	215	180	—	M12x16	4.5	424.5	36	BN 100	307	195	398	195
C 41 4	P112	28	31.3	8	250	215	180	—	M12x16	4.5	424.5	36	BN 112	325	219	424	219

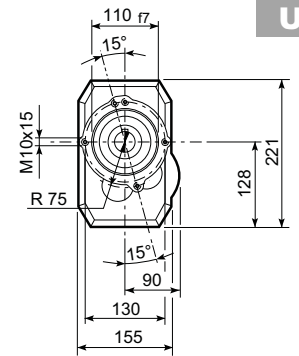
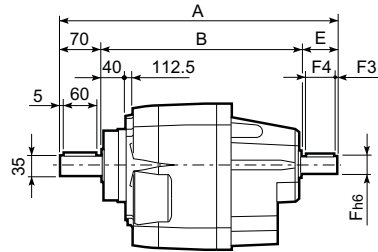
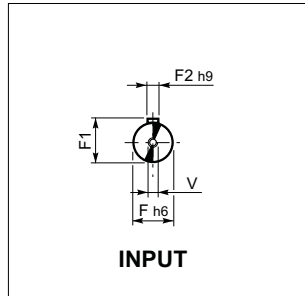
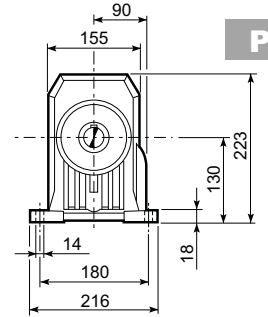
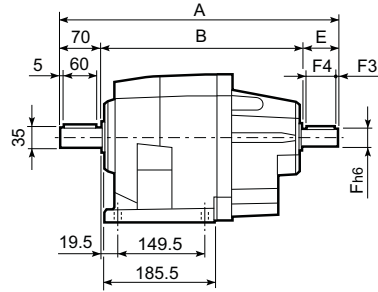
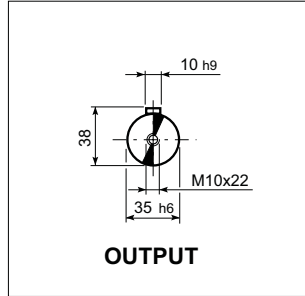
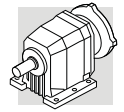

C 41 U						
	D1	D2	D3	G	T	S
FA	130	165	200	11	3.5	11
FB	180	215	250	14	4	13

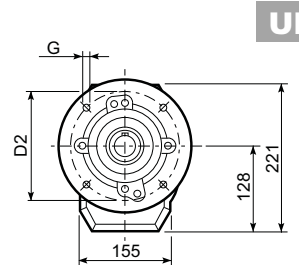
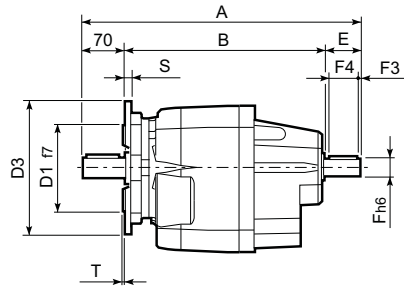

C 41											
		A	B	E	F	F1	F2	F3	F4	V	Kg
C 41 2	HS	425.5	305.5	50	24	27	8	2.5	45	M8x19	30
C 41 3		425.5	305.5	50	24	27	8	2.5	45	M8x19	30
C 41 4		448	338	40	19	21.5	6	2.5	35	M6x16	33

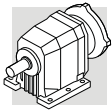

C 51...M

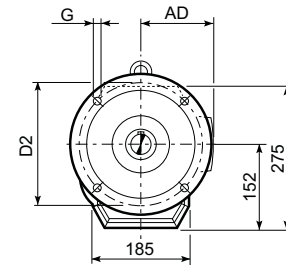
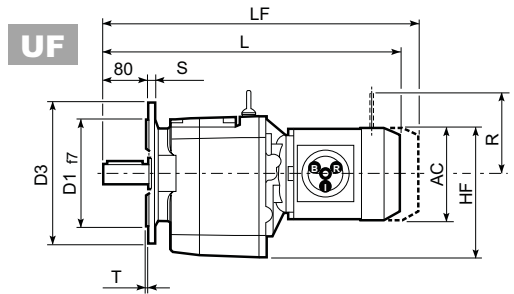
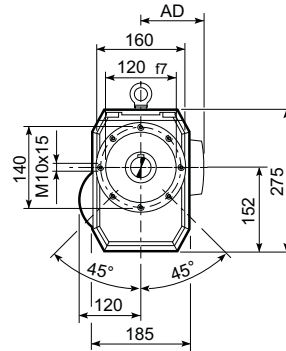
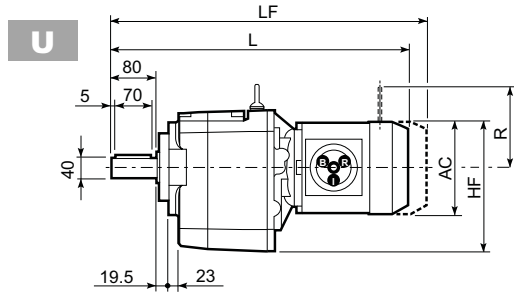
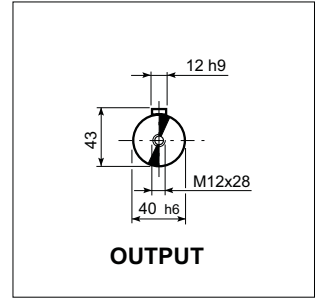
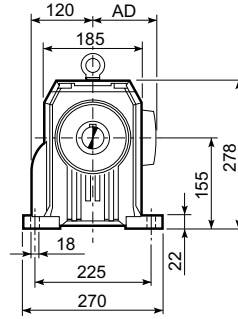
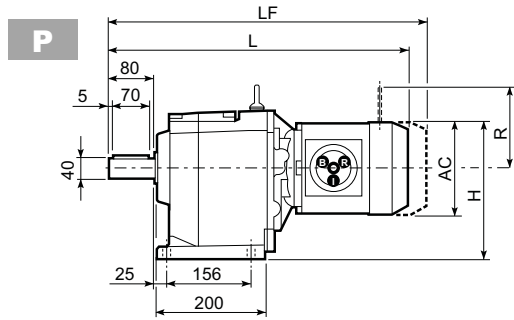

C 51 U						
	D1	D2	D3	G	T	S
FA	180	215	250	14	4	13
FB	230	265	300	14	4	16

C 51														
			M...FD M...FA							M...FD		M...FA		
			AC	H	HF	L	AD		LF		R	AD	R	AD
C 51 2/3	S1	M1S	138	224	221	493.5	108	48	556.5	50	103	132	124	108
C 51 2/3	S1	M1L	138	224	221	517.5	108	49	578.5	52	103	132	124	108
C 51 2/3	S2	M2S	156	233	230	545.5	119	53	616.5	57	129	143	134	119
C 51 2/3	S3	M3S	195	252.5	249.5	589.5	142	58	685.5	65	160	155	160	142
C 51 2/3	S3	M3L	195	252.5	249.5	621.5	142	65	712.5	72	160	155	160	142
C 51 2/3	S4	M4	258	284	281	729.5	193	99	838.5	117	226	193	217	193
C 51 2/3	S4	M4LC	258	284	281	764.5	193	107	863.5	125	226	193	217	193
C 51 4	S1	M1S	138	224	221	565	108	51	628	54	103	132	124	108
C 51 4	S1	M1L	138	224	221	589	108	52	650	55	103	132	124	108
C 51 4	S2	M2S	156	233	230	617	119	56	688	60	129	143	134	119
C 51 4	S3	M3S	195	252.5	249.5	661	142	61	757	68	160	155	160	142
C 51 4	S3	M3L	195	252.5	249.5	693	142	68	784	75	160	155	160	142

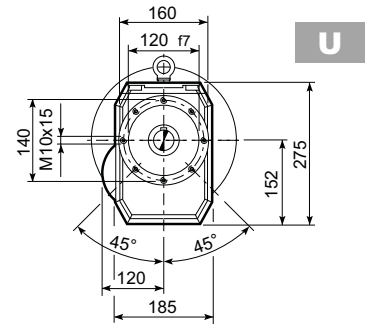
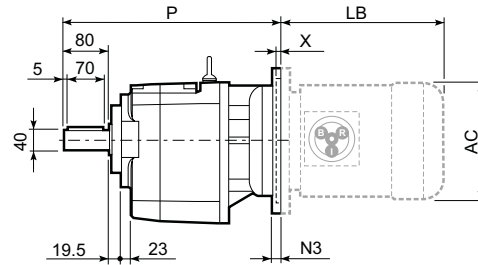
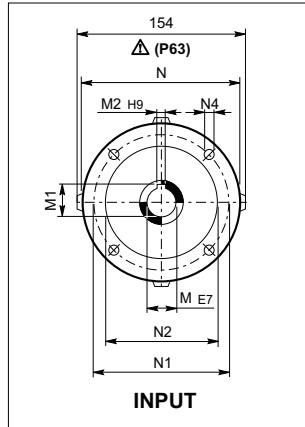
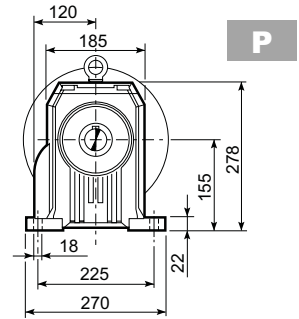
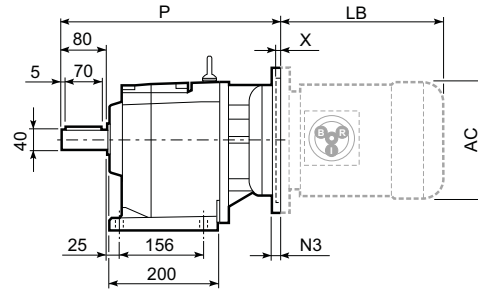
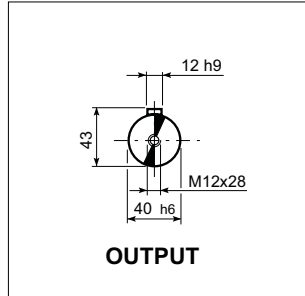
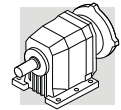

C 51 U						
	D1	D2	D3	G	T	S
FA	180	215	250	14	4	13
FB	230	265	300	14	4	16

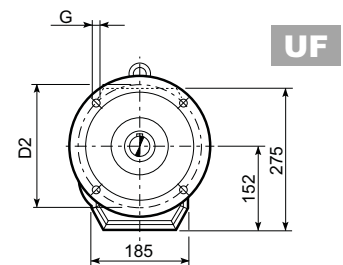
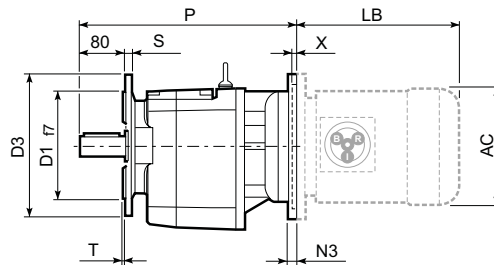

C 51													BN...		BN...FD BN...FA		
		M	M1	M2	N	N1	N2	N3	N4	X	P		LB	AC	LB	AC	
C 51 2/3	P63	11	12.8	4	140	115	95	—	M8x19	4	362.5	45	BN 63	184	121	249	121
C 51 2/3	P71	14	16.3	5	160	130	110	—	M8x16	4.5	362.5	45	BN 71	219	138	280	138
C 51 2/3	P80	19	21.8	6	200	165	130	—	M10x12	4	382	47	BN 80	234	156	306	156
C 51 2/3	P90	24	27.3	8	200	165	130	—	M10x12	4	382	47	BN 90	276	176	359	176
C 51 2/3	P100	28	31.3	8	250	215	180	—	M12x16	4.5	392	51	BN 100	307	195	398	195
C 51 2/3	P112	28	31.3	8	250	215	180	—	M12x16	4.5	392	51	BN 112	325	219	424	219
C 51 2/3	P132	38	41.3	10	300	265	230	16	14	5	428.5	54	BN 132	413	258	523	258
C 51 2/3	P160	42	45.3	12	350	300	250	23	18	5.5	479	58	BN 160MR	452	258	562	258
													BN 160M/L	486	310	626	310
C 51 2/3	P180	48	51.8	14	350	300	250	23	18	5.5	479	58	BN 180M	530	310	670	310
													BN 180L	598	348	756	348
C 51 4	P63	11	12.8	4	140	115	95	—	M8x19	4	434	47	BN 63	184	121	249	121
C 51 4	P71	14	16.3	5	160	130	110	—	M8x16	4.5	434	47	BN 71	219	138	280	138
C 51 4	P80	19	21.8	6	200	165	130	—	M10x12	4	453.5	49	BN 80	234	156	306	156
C 51 4	P90	24	27.3	8	200	165	130	—	M10x12	4	463.5	49	BN 90	276	176	359	176
C 51 4	P100	28	31.3	8	250	215	180	—	M12x16	4.5	463.5	53	BN 100	307	195	398	195
C 51 4	P112	28	31.3	8	250	215	180	—	M12x16	4.5	463.5	53	BN 112	325	219	424	219

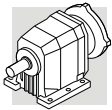

C 51...HS

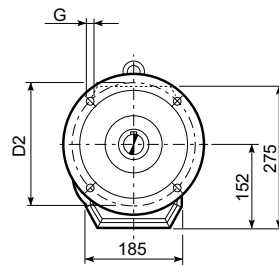
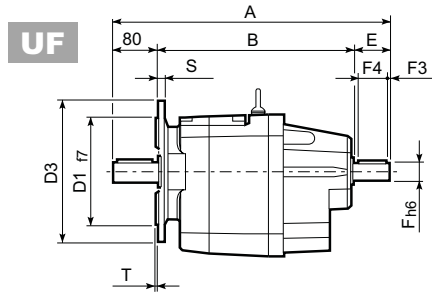
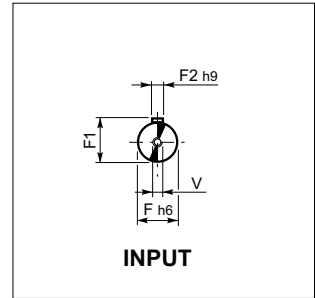
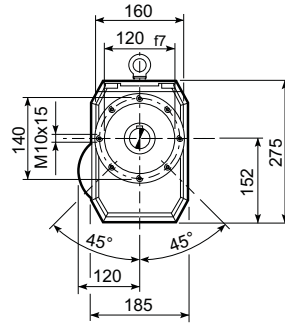
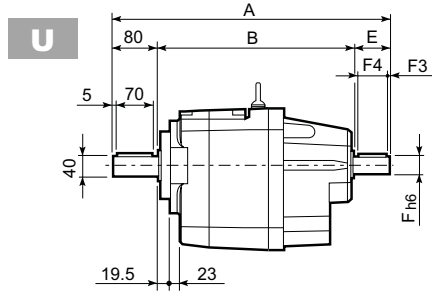
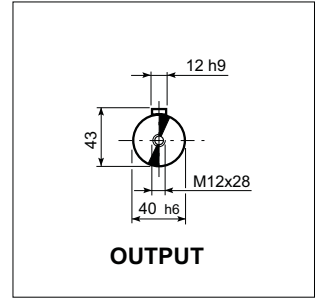
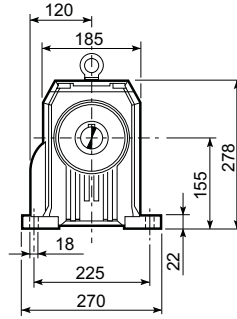
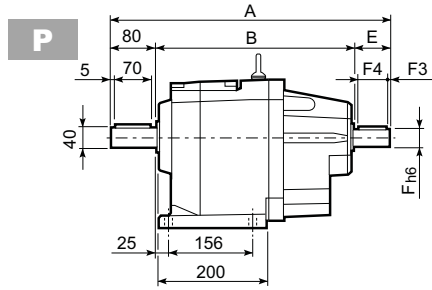

C 51 U						
	D1	D2	D3	G	T	S
FA	180	215	250	14	4	13
FB	230	265	300	14	4	16

C 51											
		A	B	E	F	F1	F2	F3	F4	V	Kg
C 51 2	HS	451.5	322	50	24	24	8	2.5	45	M8x19	45
C 51 3		451.5	322	50	24	24	8	2.5	45	M8x19	45
C 51 4		484	364	40	19	21.5	6	2.5	35	M6x16	48

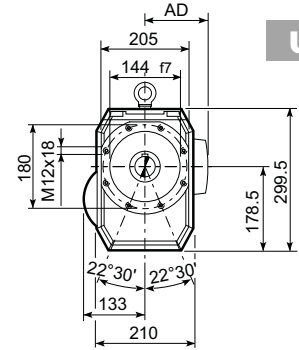
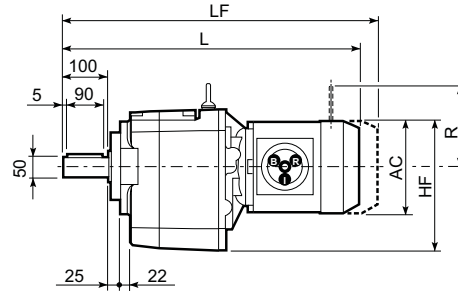
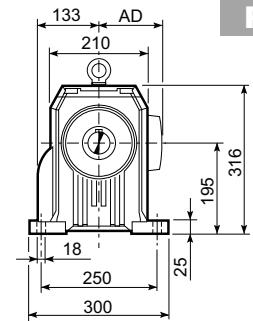
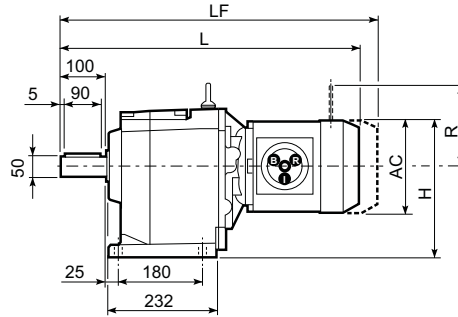
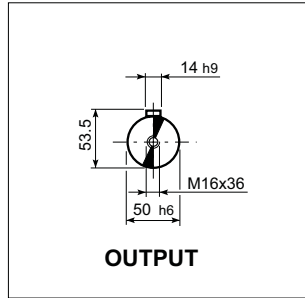
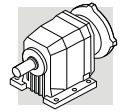

C 61_U						
	D1	D2	D3	G	T	S
FA	230	265	300	14	4	16
FB	250	300	350	18	5	18

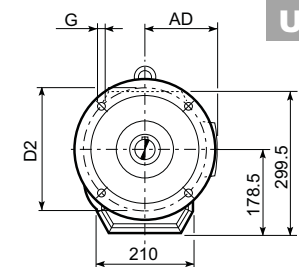
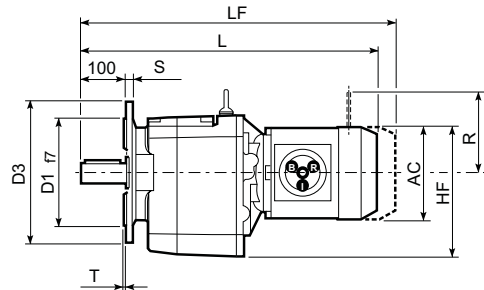

C 61																	
										M...FD M...FA		M...FD		M...FA			
			AC	H	HF	L	AD	Kg	LF	Kg	R	AD	R	AD			
			C 61 2/3	S2	M2S	156	273	256.5	598.5	119	61	669.5	65	129	143	134	119
			C 61 2/3	S3	M3S	195	292.5	276	642.5	142	66	738.5	74	160	155	160	142
			C 61 2/3	S3	M3L	195	292.5	276	674.5	142	74	765.5	81	160	155	160	142
			C 61 2/3	S4	M4	258	324	307.5	782.5	193	108	891.5	126	226	193	217	193
			C 61 2/3	S4	M4LC	258	324	307.5	817.5	193	116	916.5	134	226	193	217	193
			C 61 2/3	S5	M5S	310	350	333.5	869	245	136	1009	166	266	245	247	245
			C 61 2/3	S5	M5L	310	350	333.5	913	245	152	1053	182	266	245	247	245
			C 61 4	S1	M1S	138	264	247.5	617	108	69	680	72	103	132	124	108
			C 61 4	S1	M1L	138	264	247.5	641	108	71	702	74	103	132	124	108
			C 61 4	S2	M2S	156	273	256.5	669	119	75	740	78	129	143	134	119
			C 61 4	S3	M3S	195	292.5	276	713	142	79	809	87	160	155	160	142
			C 61 4	S3	M3L	195	292.5	276	745	142	87	836	94	160	155	160	142

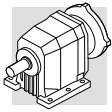

C 61...P(IEC)

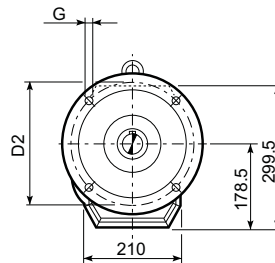
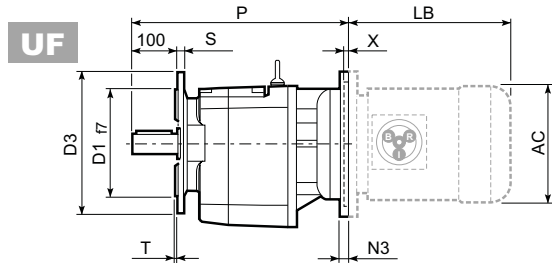
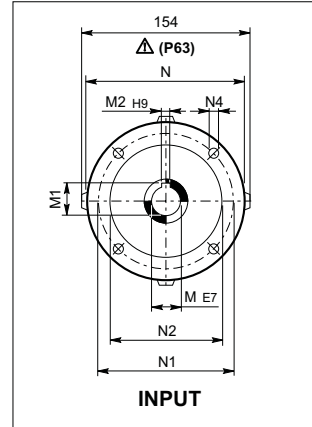
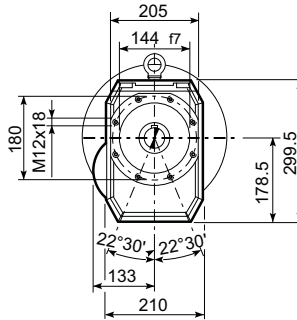
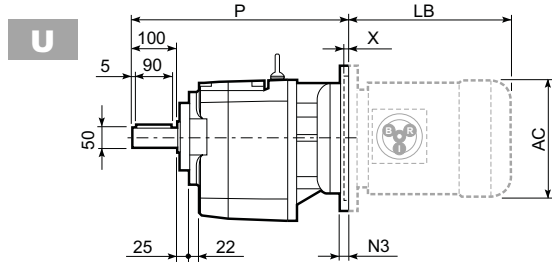
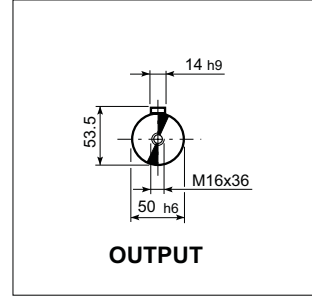
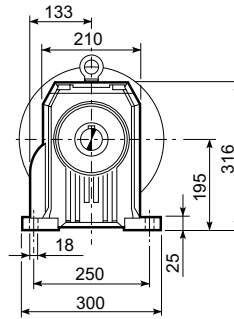
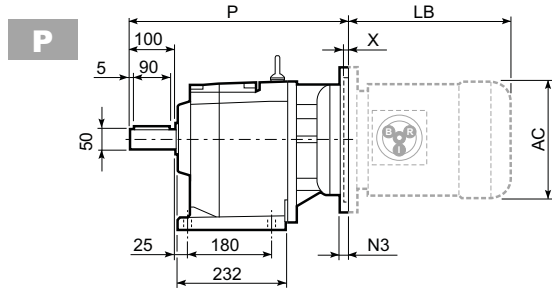

C 61 U						
	D1	D2	D3	G	T	S
FA	230	265	300	14	4	16
FB	250	300	350	18	5	18

C 61													BN...		BN...FD BN...FA		
		M	M1	M2	N	N1	N2	N3	N4	X	P	kg	IEC	LB	AC	LB	AC
C 61 2/3	P63	11	12.8	4	140	115	95	—	M8x19	4	415.5	55	BN 63	184	121	249	121
C 61 2/3	P71	14	16.3	5	160	130	110	—	M8x16	4.5	415.5	57	BN 71	219	138	280	138
C 61 2/3	P80	19	21.8	6	200	165	130	—	M10x12	4	435	61	BN 80	234	156	306	156
C 61 2/3	P90	24	27.3	8	200	165	130	—	M10x12	4	435	61	BN 90	276	176	359	176
C 61 2/3	P100	28	31.3	8	250	215	180	—	M12x16	4.5	444	65	BN 100	307	195	398	195
C 61 2/3	P112	28	31.3	8	250	215	180	—	M12x16	4.5	444	65	BN 112	325	219	424	219
C 61 2/3	P132	38	41.3	10	300	265	230	16	14	5	481.5	68	BN 132	413	258	523	258
C 61 2/3	P160	42	45.3	12	350	300	250	23	18	5.5	532	73	BN 160MR	452	258	562	258
													BN 160M/L	486	310	626	310
C 61 2/3	P180	48	51.8	14	350	300	250	23	18	5.5	532	73	BN 180M	530	310	670	310
													BN 180L	598	348	756	348
C 61 4	P63	11	12.8	4	140	115	95	—	M8x19	4	486	61	BN 63	184	121	249	121
C 61 4	P71	14	16.3	5	160	130	110	—	M8x16	4.5	489	63	BN 71	219	138	280	138
C 61 4	P80	19	21.8	6	200	165	130	—	M10x12	4	505.5	67	BN 80	234	156	306	156
C 61 4	P90	24	27.3	8	200	165	130	—	M10x12	4	505.5	67	BN 90	276	176	359	176
C 61 4	P100	28	31.3	8	250	215	180	—	M12x16	4.5	515.5	71	BN 100	307	195	398	195
C 61 4	P112	28	31.3	8	250	215	180	—	M12x16	4.5	515.5	71	BN 112	325	219	424	219

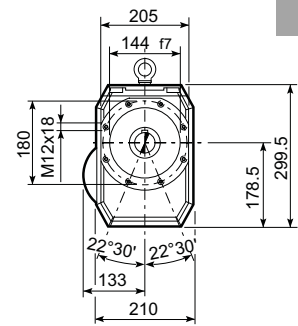
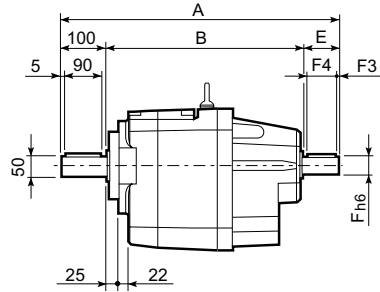
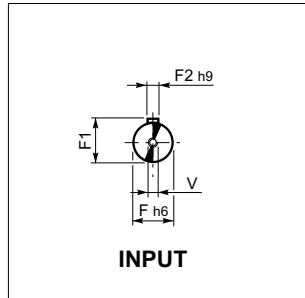
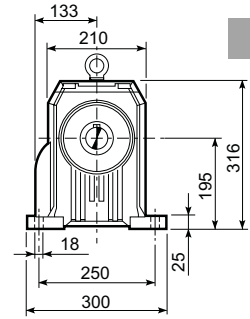
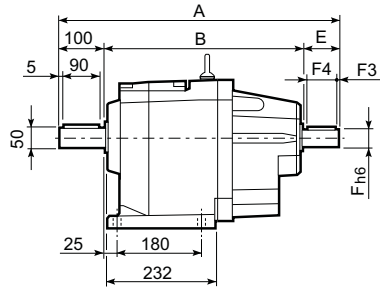
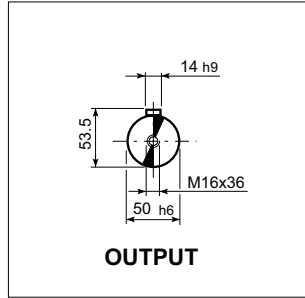
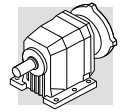

C 61 U						
	D1	D2	D3	G	T	S
FA	230	265	300	14	4	16
FB	250	300	350	18	5	18

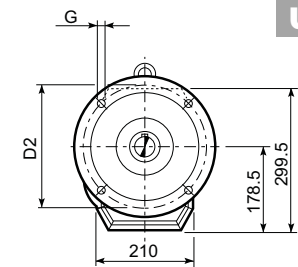
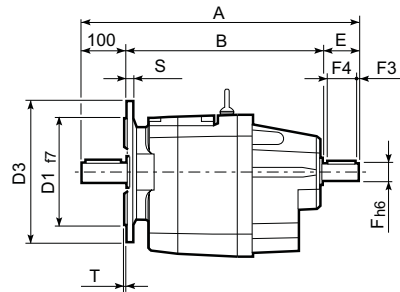

C 61												
		A	B	E	F	F1	F2	F3	F4	V	Kg	
C 61 2	HS	532	372	60	28	31	8	5	50	M10x22	66	
C 61 3		532	372	60	28	31	8	5	50	M10x22	66	
C 61 4		575	425	50	24	27	8	2.5	45	M8x19	72	

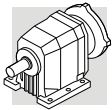

C 70...M

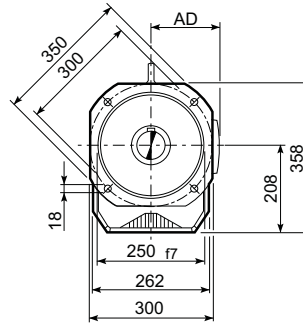
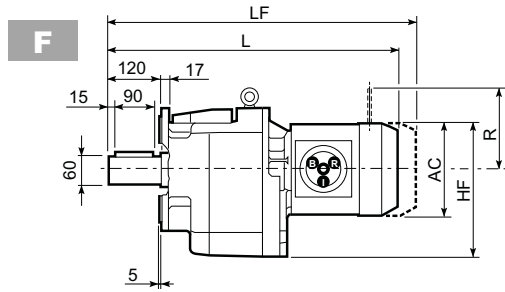
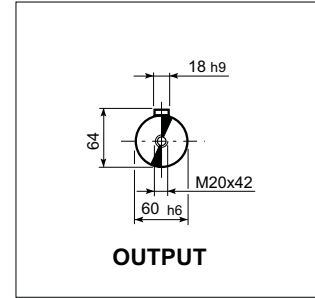
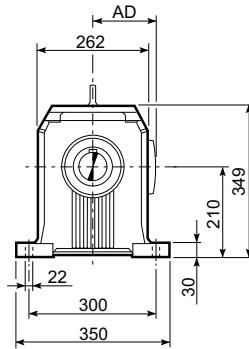
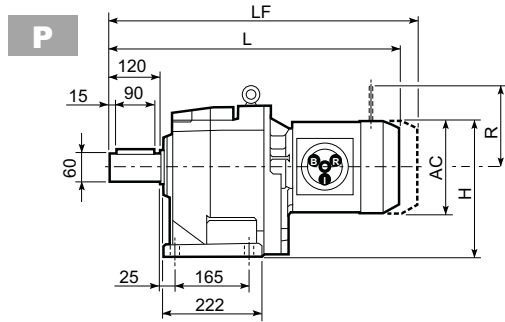

C 70														
									M...FD M...FA		M...FD		M...FA	
			AC	H	HF	L	AD		LF		R	AD	R	AD
C 70 2/3	S2	M2S	156	288	286	636.5	119	88	707.5	92	129	143	134	119
C 70 2/3	S3	M3S	195	307.5	305.5	680.5	142	93	776.5	101	160	155	160	142
C 70 2/3	S3	M3L	195	307.5	305.5	712.5	142	101	803.5	108	160	155	160	142
C 70 2/3	S4	M4	258	339	337	820.5	193	135	929.5	153	226	193	217	193
C 70 2/3	S4	M4LC	258	339	337	855.5	193	143	954.5	161	226	193	217	193
C 70 2/3	S5	M5S	310	365	363	907	245	163	1047	193	266	245	247	245
C 70 2/3	S5	M5L	310	365	363	951	245	179	1091	209	266	245	247	245
C 70 4	S1	M1S	138	279	277	635.5	108	87	698.5	90	103	132	124	108
C 70 4	S1	M1L	138	279	277	659.5	108	88	720.5	91	103	132	124	108
C 70 4	S2	M2S	156	288	286	687.5	119	92	758.5	96	129	143	134	119
C 70 4	S3	M3S	195	307.5	305.5	731.5	142	97	827.5	104	160	155	160	142
C 70 4	S3	M3L	195	307.5	305.5	763.5	142	104	854.5	111	160	155	160	142
C 70 4	S4	M4	258	339	337	871.5	193	138	980.5	156	226	193	217	193

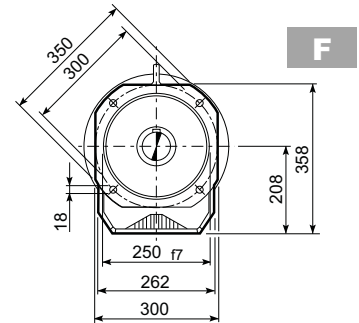
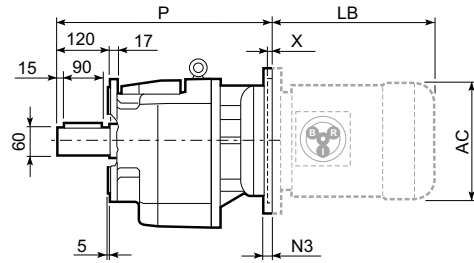
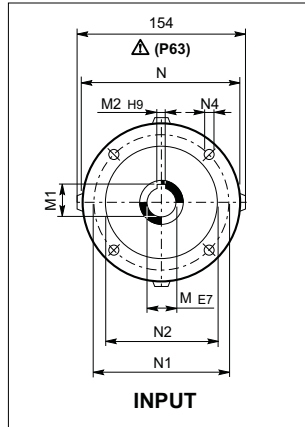
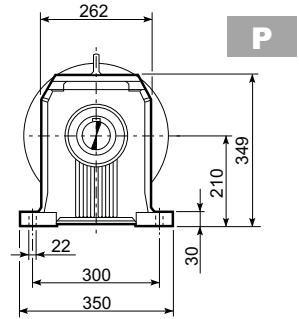
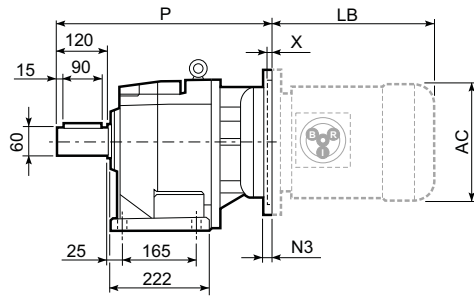
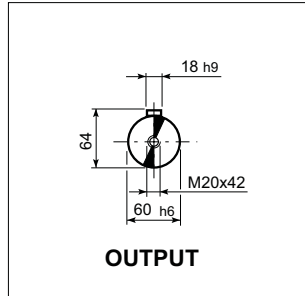
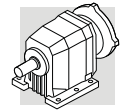

C 70													BN...		BN...FD BN...FA		
		M	M1	M2	N	N1	N2	N3	N4	X	P			LB	AC	LB	AC
C 70 2/3	P80	19	21.8	6	200	165	130	—	M10x12	4	473	88	BN 80	234	156	306	156
C 70 2/3	P90	24	27.3	8	200	165	130	—	M10x12	4	473	88	BN 90	276	176	359	176
C 70 2/3	P100	28	31.3	8	250	215	180	—	M12x16	4.5	483	92	BN 100	307	195	398	195
C 70 2/3	P112	28	31.3	8	250	215	180	—	M12x16	4.5	483	92	BN 112	325	219	424	219
C 70 2/3	P132	38	41.3	10	300	265	230	16	14	5	519.5	95	BN 132	413	258	523	258
C 70 2/3	P160	42	45.3	12	350	300	250	23	18	6	575	107	BN 160MR	452	258	562	258
													BN 160M/L	486	310	626	310
C 70 2/3	P180	48	51.8	14	350	300	250	23	18	6	575	107	BN 180M	530	310	670	310
													BN 180L	598	348	756	348
C 70 2/3	P200	55	59.3	16	400	350	300	—	M16x25	7	600	129	BN 200L	612	348	768	348
C 70 4	P63	11	12.8	4	140	115	95	—	M8x19	4	504.5	91	BN 63	184	121	249	121
C 70 4	P71	14	16.3	5	160	130	110	—	M8x16	4.5	504.5	91	BN 71	219	138	280	138
C 70 4	P80	19	21.8	6	200	165	130	—	M10x12	4	524	92	BN 80	234	156	306	156
C 70 4	P90	24	27.3	8	200	165	130	—	M10x12	4	524	92	BN 90	276	176	359	176
C 70 4	P100	28	31.3	8	250	215	180	—	M12x16	4.5	534	96	BN 100	307	195	398	195
C 70 4	P112	28	31.3	8	250	215	180	—	M12x16	4.5	534	96	BN 112	325	219	424	219
C 70 4	P132	38	41.3	10	300	265	230	16	14	5	570.5	98	BN 132	413	258	523	258

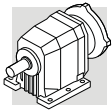

C 70...HS

P

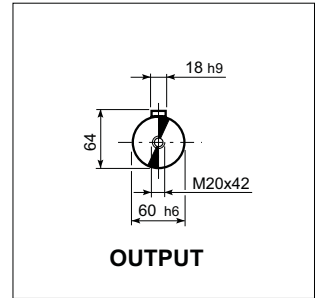
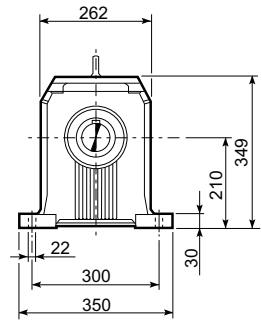
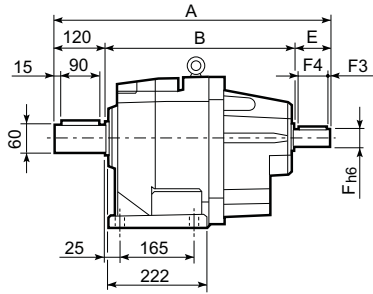

F

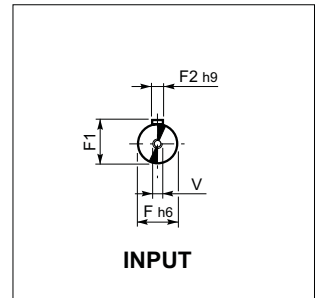
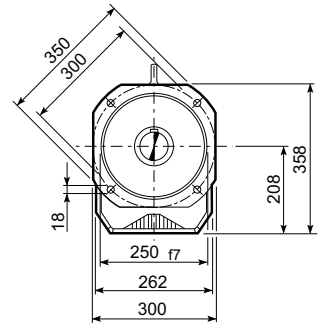
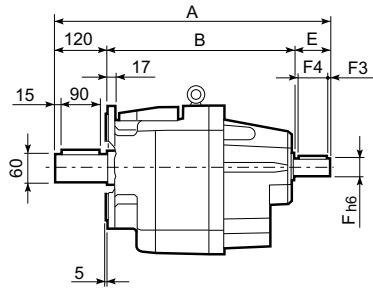

C 70											
		A	B	E	F	F1	F2	F3	F4	V	Kg
	HS	657.5	427.5	110	42	45	12	10	90	M12x28	108
C 70 2		657.5	427.5	110	42	45	12	10	90	M12x28	108
C 70 3		593.5	423.5	50	24	27	8	2.5	45	M8x19	94
C 70 4											

C 80...M

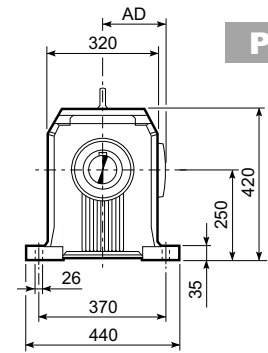
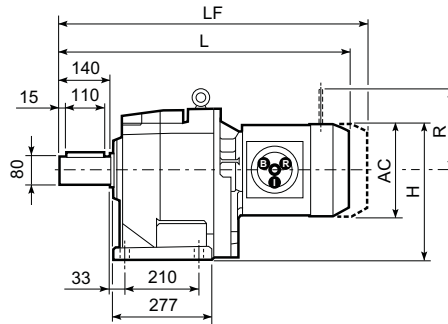
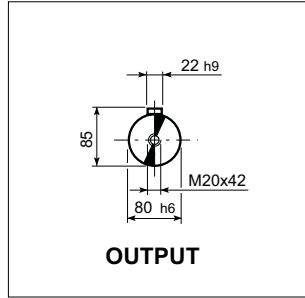
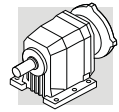

P

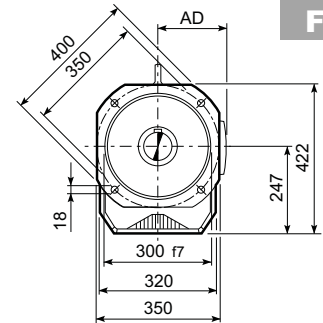
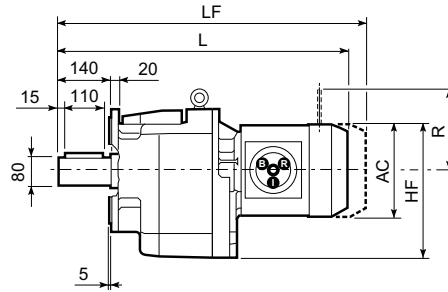

F

C 80														
			AC	H	HF	L	AD	Kg	M...FD M...FA		M...FD		M...FA	
									LF	Kg	R	AD	R	AD
C 80 2/3	S3	M3S	195	347.5	344.5	742.5	142	139	838.5	146	160	155	160	142
C 80 2/3	S3	M3L	195	347.5	344.5	774.5	142	146	865.5	153	160	155	160	142
C 80 2/3	S4	M4	258	379	376	882.5	193	180	991.5	196	226	193	217	193
C 80 2/3	S4	M4LC	258	379	376	917.5	193	188	1016.5	204	226	193	217	193
C 80 2/3	S5	M5S	310	405	402	969	245	208	1109	238	266	245	247	245
C 80 2/3	S5	M5L	310	405	402	1013	245	224	1153	254	266	245	247	245
C 80 4	S1	M1S	138	319	316	709.5	108	132	772.5	135	103	132	124	108
C 80 4	S1	M1L	138	319	316	733.5	108	133	794.5	136	103	132	124	108
C 80 4	S2	M2S	156	328	325	761.5	119	137	832.5	141	129	143	134	119
C 80 4	S3	M3S	195	347.5	344.5	805.5	142	142	901.5	149	160	155	160	142
C 80 4	S3	M3L	195	347.5	344.5	837.5	142	149	928.5	156	160	155	160	142
C 80 4	S4	M4	258	379	376	945.5	193	183	1054.5	201	226	193	217	193

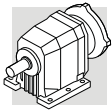

C 80...P(IEC)

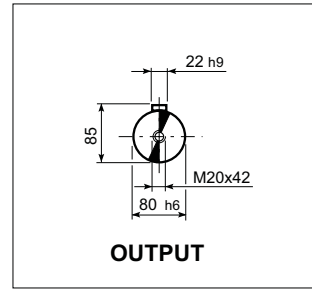
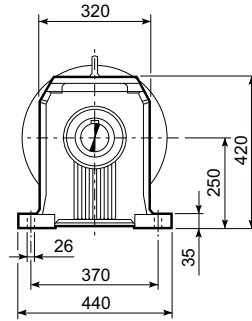
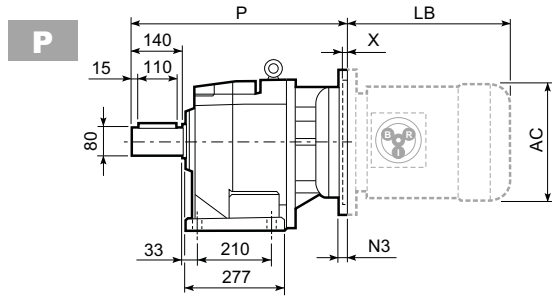

OUTPUT

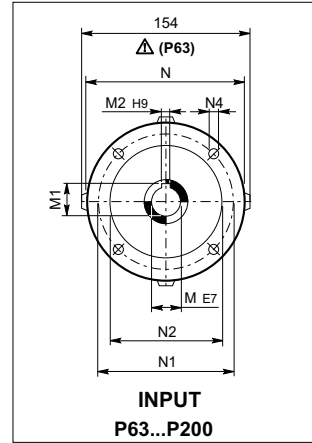
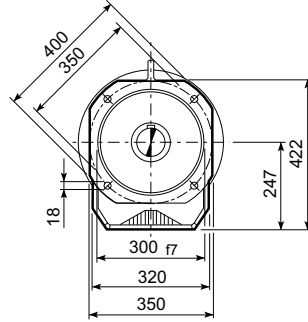
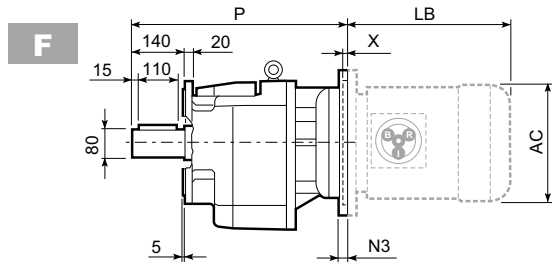

**INPUT
P63...P200**

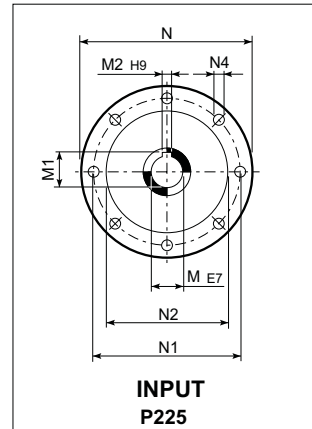

**INPUT
P225**

C 80													BN...		BN...FD BN...FA		
		M	M1	M2	N	N1	N2	N3	N4	X	P			LB	AC	LB	AC
C 80 2/3	P80	19	21.8	6	200	165	130	—	M10x12	4	533	135	BN 80	234	156	306	156
C 80 2/3	P90	24	27.3	8	200	165	130	—	M10x12	4	533	135	BN 90	276	176	359	176
C 80 2/3	P100	28	31.3	8	250	215	180	—	M12x16	4.5	543	139	BN 100	307	195	398	195
C 80 2/3	P112	28	31.3	8	250	215	180	—	M12x16	4.5	543	139	BN 112	325	219	424	219
C 80 2/3	P132	38	41.3	10	300	265	230	16	14	5	579.5	141	BN 132	413	258	523	258
C 80 2/3	P160	42	45.3	12	350	300	250	23	18	6	635	154	BN 160MR	452	258	562	258
													BN 160M/L	486	310	626	310
C 80 2/3	P180	48	51.8	14	350	300	250	23	18	6	635	154	BN 180M	530	310	670	310
													BN 180L	598	348	756	348
C 80 2/3	P200	55	59.3	16	400	350	300	—	M16x25	7	660	176	BN 200L	612	348	768	348
C 80 2/3	P225	60	64.4	18	450	400	350	25	18	6	705.5	178	BN 225	—	—	—	—
C 80 4	P63	11	12.8	4	140	115	95	—	M8x19	4	576.5	138	BN 63	184	121	249	121
C 80 4	P71	14	16.3	5	160	130	110	—	M8x16	4.5	576.5	138	BN 71	219	138	280	138
C 80 4	P80	19	21.8	6	200	165	130	—	M10x12	4	596	140	BN 80	234	156	306	156
C 80 4	P90	24	27.3	8	200	165	130	—	M10x12	4	596	140	BN 90	276	176	359	176
C 80 4	P100	28	31.3	8	250	215	180	—	M12x16	4.5	606	144	BN 100	307	195	398	195
C 80 4	P112	28	31.3	8	250	215	180	—	M12x16	4.5	606	144	BN 112	325	219	424	219
C 80 4	P132	38	41.3	10	300	265	230	16	M12x16	5	642.5	146	BN 132	413	258	523	258

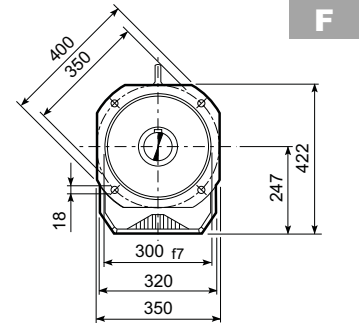
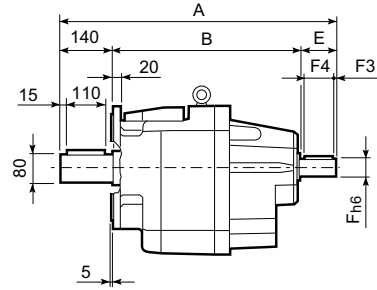
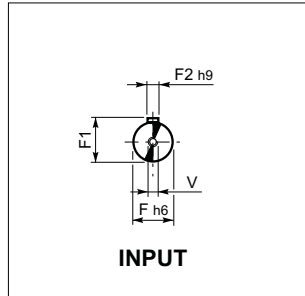
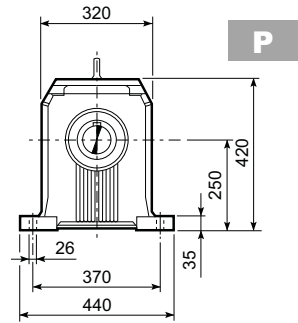
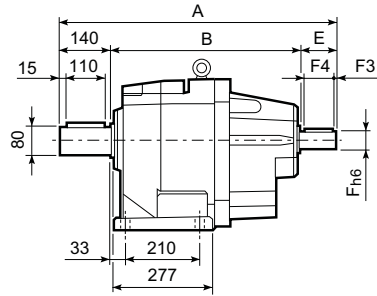
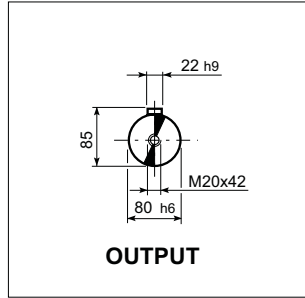
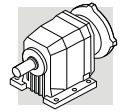

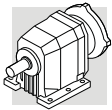

C 80											
		A	B	E	F	F1	F2	F3	F4	V	kg
C 80 2	HS	718.5	468.5	110	42	45	12	10	90	M12x28	154
C 80 3		718.5	468.5	110	42	45	12	10	90	M12x28	154
C 80 4		666.5	476.5	50	24	27	8	2.5	45	M8x19	141

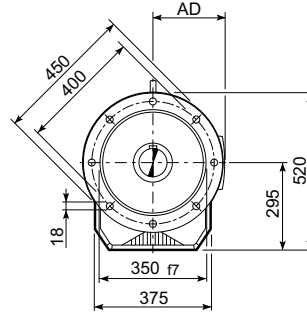
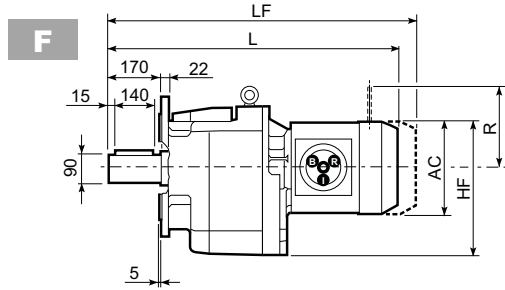
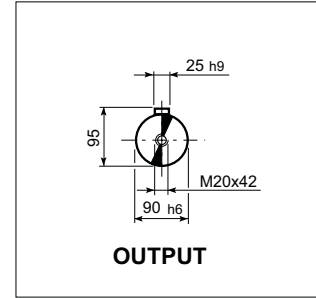
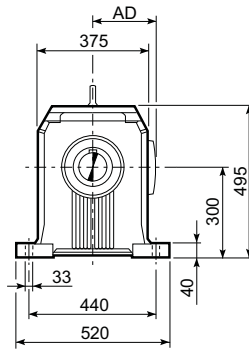
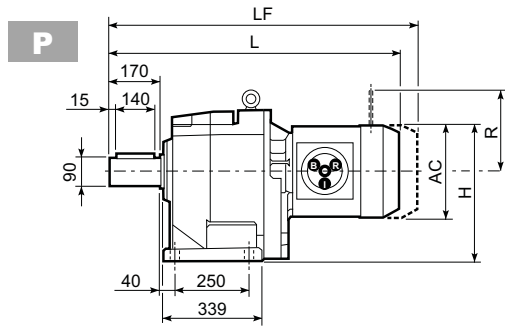

C 90...M



C 90													
  	AC	H	HF	L	AD	Kg	M...FD M...FA		M...FD		M...FA		
							LF	Kg	R	AD	R	AD	
C 90 2/3 S3 M3S	195	397.5	392.5	852	142	228	948	236	160	155	160	142	
C 90 2/3 S3 M3L	195	397.5	392.5	884	142	236	975	243	160	155	160	142	
C 90 2/3 S4 M4	258	429	424	992	193	270	1101	288	226	193	217	193	
C 90 2/3 S4 M4LC	258	429	424	1027	193	278	1126	296	226	193	217	193	
C 90 2/3 S5 M5S	310	455	450	1078.5	245	298	1218.5	328	266	245	247	245	
C 90 2/3 S5 M5L	310	455	450	1122.5	245	314	1262.5	344	266	245	247	245	
C 90 4 S2 M2S	156	378	373	891	119	234	962	238	129	143	134	119	
C 90 4 S3 M3S	195	397.5	392.5	935	142	239	1031	246	160	155	160	142	
C 90 4 S3 M3L	195	397.5	392.5	967	142	246	1058	253	160	155	160	142	
C 90 4 S4 M4	258	429	424	1075	193	280	1184	298	226	193	217	193	

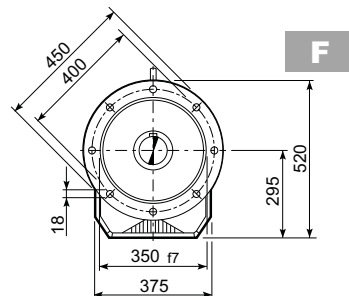
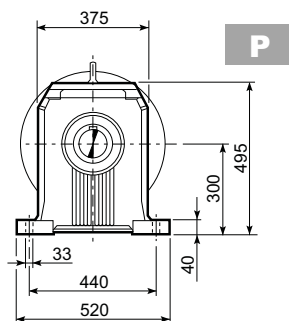
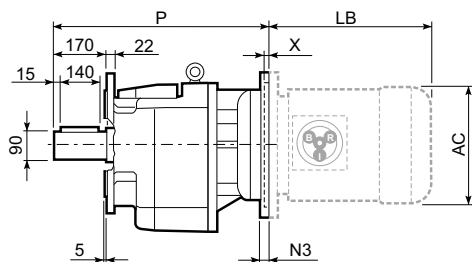
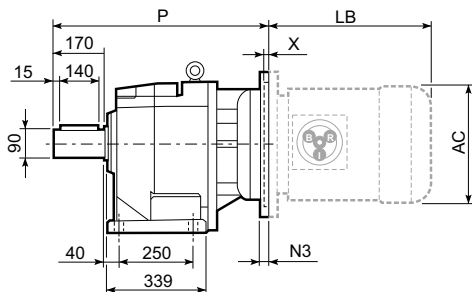
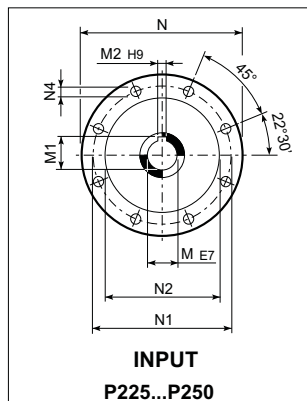
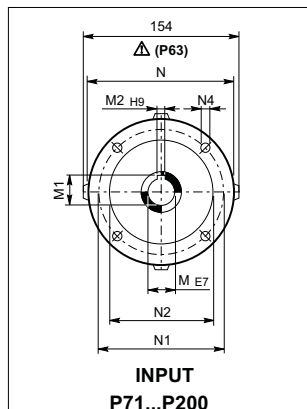
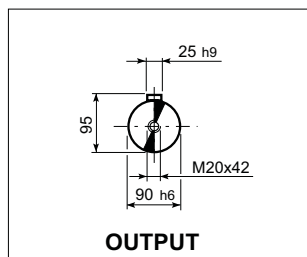
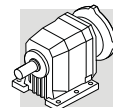

C 90													BN...		BN...FD BN...FA		
		M	M1	M2	N	N1	N2	N3	N4	X	P	kg	IEC	LB	AC	LB	AC
C 90 2/3	P80	19	21.8	6	200	165	130	—	M10x12	4	644.5	229	BN 80	234	156	306	156
C 90 2/3	P90	24	27.3	8	200	165	130	—	M10x12	4	644.5	229	BN 90	276	176	359	176
C 90 2/3	P100	28	31.3	8	250	215	180	—	M12x16	4.5	654.5	234	BN 100	307	195	398	195
C 90 2/3	P112	28	31.3	8	250	215	180	—	M12x16	4.5	654.5	234	BN 112	325	219	424	219
C 90 2/3	P132	38	41.3	10	300	265	230	16	14	5	691	236	BN 132	413	258	523	258
C 90 2/3	P160	42	45.3	12	350	300	250	23	18	6	746.5	251	BN 160MR	452	258	562	258
													BN 160M/L	486	310	626	310
C 90 2/3	P180	48	51.8	14	350	300	250	23	18	6	746.5	251	BN 180M	530	310	670	310
													BN 180L	598	348	756	348
C 90 2/3	P200	55	59.3	16	400	350	300	—	M16x25	7	771.5	272	BN 200L	612	348	768	348
C 90 2/3	P225	60	64.4	18	450	400	350	30	18	6	817	273	BN 225	—	—	—	—
C 90 2/3	P250	65	69.4	18	550	500	450	30	18	6	847	295	BN 250	—	—	—	—
C 90 4	P71	14	16.3	5	160	130	110	—	M8x16	4.5	707.5	236	BN 71	219	138	280	138
C 90 4	P80	19	21.8	6	200	165	130	—	M10x12	4	727	238	BN 80	234	156	306	156
C 90 4	P90	24	27.3	8	200	165	130	—	M10x12	4	727	238	BN 90	276	176	359	176
C 90 4	P100	28	31.3	8	250	215	180	—	M12x16	4.5	737	242	BN 100	307	195	398	195
C 90 4	P112	28	31.3	8	250	215	180	—	M12x16	4.5	737	242	BN 112	325	219	424	219
C 90 4	P132	38	41.3	10	300	265	230	16	14	5	773.5	244	BN 132	413	258	523	258
C 90 4	P160	42	45.3	12	350	300	250	23	18	5.5	824	248	BN 160MR	452	258	562	258
													BN 160M/L	486	310	626	310
C 90 4	P180	48	51.8	14	350	300	250	23	18	5.5	824	248	BN 180M	530	310	670	310
													BN 180L	598	348	756	348

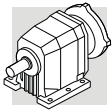

C 90...HS

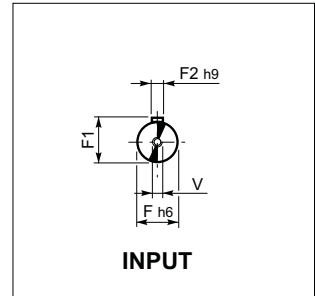
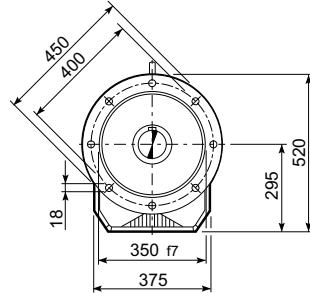
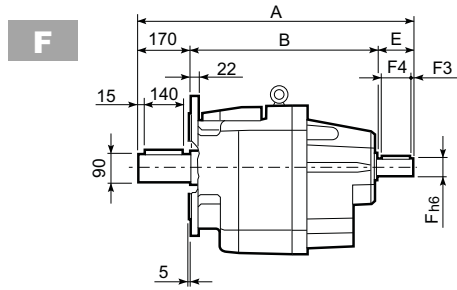
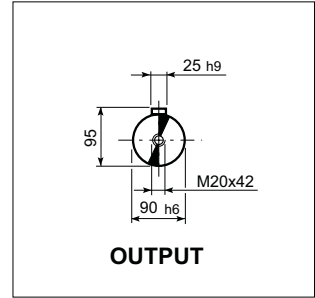
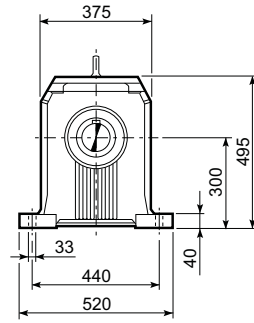
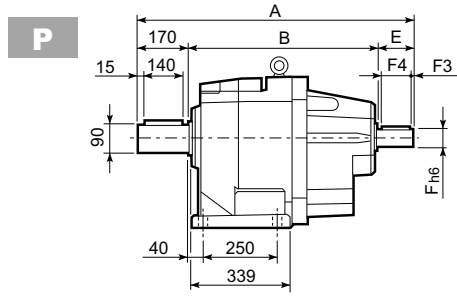

C 90											
		A	B	E	F	F1	F2	F3	F4	V	Kg
	HS	930.5	620.5	140	60	64	18	10	120	M16x36	273
		930.5	620.5	140	60	64	18	10	120	M16x36	273
		797	577	50	24	27	8	2.5	45	M8x19	240

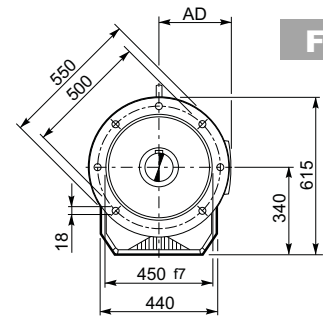
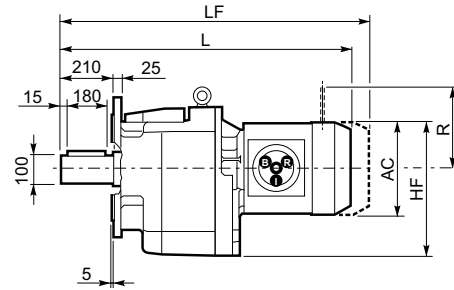
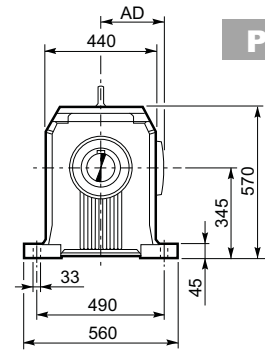
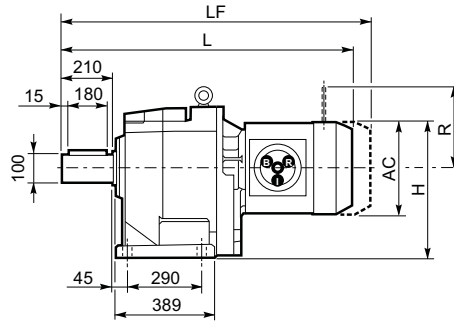
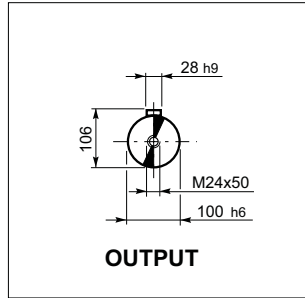
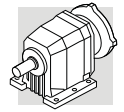

C 100															
										M...FD M...FA		M...FD		M...FA	
			AC	H	HF	L	AD		LF		R	AD	R	AD	
C 100 2/3	S4	M4	258	474	469	1087	193	392	1196	410	226	193	217	193	
C 100 2/3	S4	M4LC	258	474	469	1122	193	400	1221	418	226	193	217	193	
C 100 2/3	S5	M5S	310	500	495	1173.5	245	420	1313.5	450	266	245	247	245	
C 100 2/3	S5	M5L	310	500	495	1217.5	245	436	1357.5	466	266	245	247	245	
C 100 4	S2	M2S	156	423	418	985.5	119	354	1056.5	357	129	143	134	119	
C 100 4	S3	M3S	195	442.5	437.5	1029.5	142	358	1125.5	366	160	155	160	142	
C 100 4	S3	M3L	195	442.5	437.5	1061.5	142	366	1152.5	373	160	155	160	142	
C 100 4	S4	M4	258	474	469	1169.5	193	400	1278.5	418	226	193	217	193	
C 100 4	S4	M4LC	258	474	469	1204.5	245	408	1303.5	426	226	193	217	193	

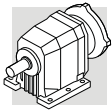

C 100...P(IEC)

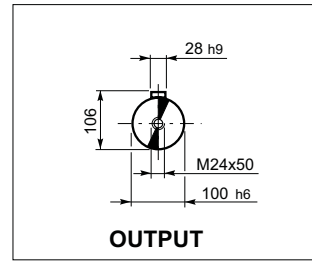
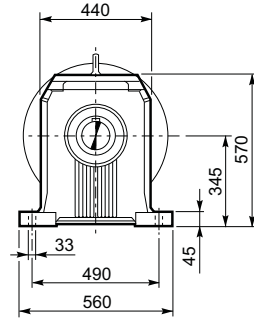
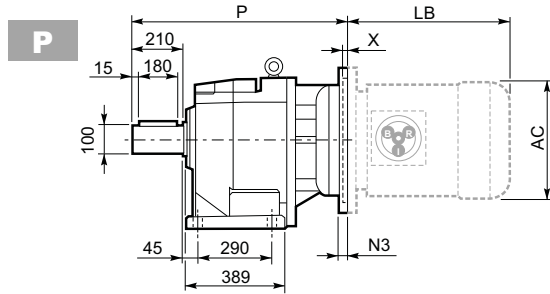

OUTPUT

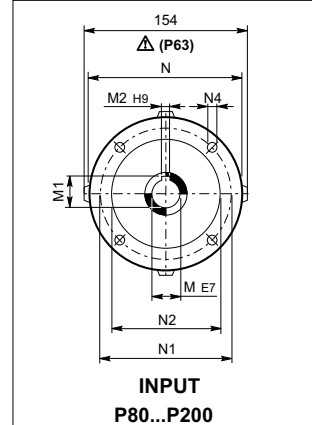
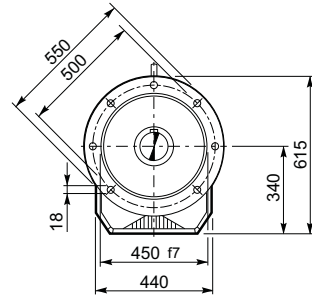
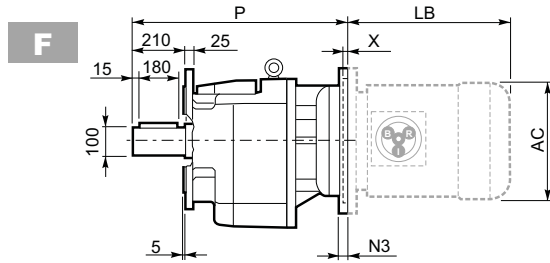

**INPUT
P80...P200**

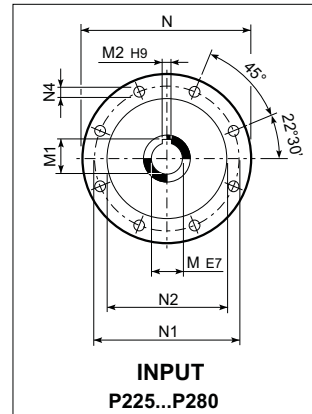

**INPUT
P225...P280**

C 100												IEC	BN...		BN...FD BN...FA		
M	M1	M2	N	N1	N2	N3	N4	X	P	kg	LB		AC	LB	AC		
C 100 2/3	P100	28	31.3	8	250	215	180	—	M12x16	4.5	749.5	364	BN 100	307	195	398	195
C 100 2/3	P112	28	31.3	8	250	215	180	—	M12x16	4.5	749.5	364	BN 112	325	219	424	219
C 100 2/3	P132	38	41.3	10	300	265	230	16	14	5	786	367	BN 132	413	258	523	258
C 100 2/3	P160	42	45.3	12	350	300	250	23	18	6	841.5	382	BN 160MR	452	258	562	258
		48	51.8	14	350	300	250	23	18	6	841.5	382	BN 160M/L	486	310	626	310
C 100 2/3	P180	48	51.8	14	350	300	250	23	18	6	841.5	382	BN 180M	530	310	670	310
		55	59.3	16	400	350	300	—	M16x25	7	866.5	403	BN 180L	598	348	756	348
C 100 2/3	P200	55	59.3	16	400	350	300	—	M16x25	7	866.5	403	BN 200L	612	348	768	348
C 100 2/3	P225	60	64.4	18	450	400	350	30	18	7	912	403	BN 225	—	—	—	—
C 100 2/3	P250	65	69.4	18	550	500	450	30	18	7	942	426	BN 250	—	—	—	—
C 100 2/3	P280	75	79.9	20	550	500	450	30	18	6	942	426	BN 280	—	—	—	—
C 100 4	P80	19	21.8	6	200	165	130	—	M10x12	4	822.5	371	BN 80	234	156	306	156
C 100 4	P90	24	27.3	8	200	165	130	—	M10x12	4	822.5	371	BN 90	276	176	359	176
C 100 4	P100	28	31.3	8	250	215	180	—	M12x16	4.5	832.5	375	BN 100	307	195	398	195
C 100 4	P112	28	31.3	8	250	215	180	—	M12x16	4.5	832.5	375	BN 112	325	219	424	219
C 100 4	P132	38	41.3	10	300	265	230	16	14	5	869	377	BN 132	413	258	523	258
C 100 4	P160	42	45.3	12	350	300	250	23	18	5.5	919.5	381	BN 160MR	452	258	562	258
		48	51.8	14	350	300	250	23	18	5.5	919.5	381	BN 160M/L	486	310	626	310
C 100 4	P180	48	51.8	14	350	300	250	23	18	5.5	919.5	381	BN 180M	530	310	670	310
		55	59.3	16	400	350	300	—	M16x25	7	942	426	BN 180L	598	348	756	348

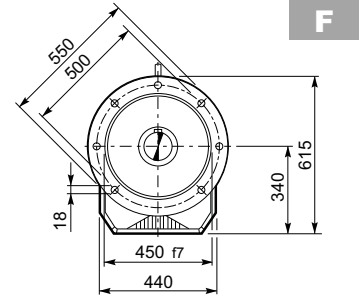
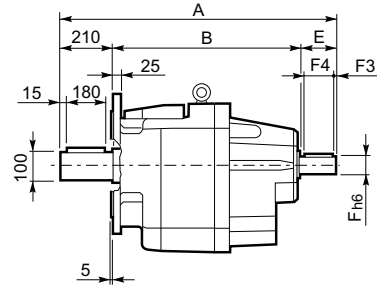
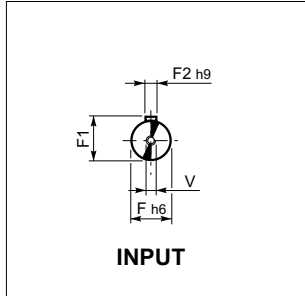
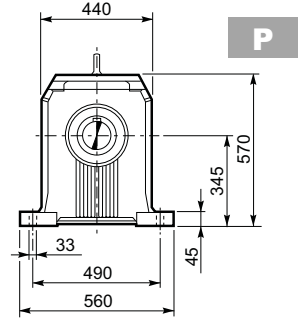
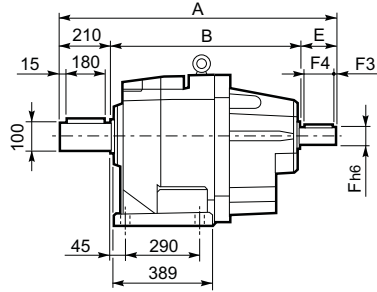
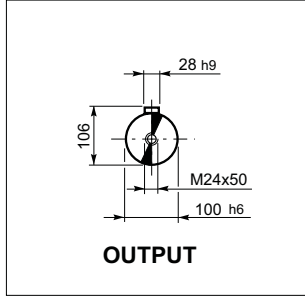
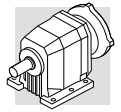

C 100											
		A	B	E	F	F1	F2	F3	F4	V	kg
C 100 2	HS	1025.5	676	140	60	64	18	10	120	M16x36	409
C 100 3		1025.5	676	140	60	64	18	10	120	M16x36	409
C 100 4		892	632	50	24	27	8	2.5	45	M8x19	372