

1000 Series

1006TAG2

Diesel Engine – ElectropaK

143 kWm 1500 rev/min

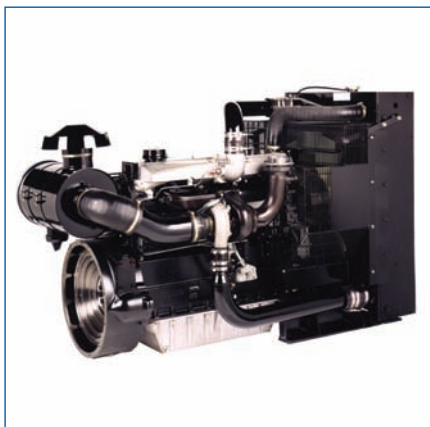

Economic power

- Single side servicing for reduced service time and cost.
- Unique Fastram combustion system enables high power output plus low fuel consumption.
- Electronic governor gives close control for 50 Hz (1500 rpm) operation.

Durable power

- Maximum cooling efficiency is provided by a gear driven water pump and independent fan drive.
- Leak free operation is ensured by Viton crankshaft seals and sophisticated controlled swell joints, giving protection in the toughest conditions.
- Inserted valve seats, oil spray cooled pistons and compact plate cooler give enhanced engine life.

Reliable power

- Suitable for operation in ambient temperatures up to 53°C (46°C if a canopy is fitted).
- Fuelled starting aid for temperatures down to -20°C.

Product Support

- Perkins actively pursues product support excellence by ensuring our distribution network invest in their territory - strengthening relationships and providing more value to you, our customer
- Through an experienced global network of distributors and dealers, fully trained engine experts deliver total service support around the clock, 365 days a year. They have a comprehensive suite of web based tools at their fingertips covering technical information, parts identification and ordering systems, all dedicated to maximising the productivity of your engine
- Throughout the entire life of a Perkins engine, we provide access to genuine OE specification parts and service. We give 100% reassurance that you receive the very best in terms of quality for lowest possible cost .. wherever your Perkins powered machine is operating in the world

The Perkins 1000 Series family of ElectropaK engines are renowned throughout the power generation industry for their superior performance and reliability.

The 1006TAG2 is a turbocharged, 6 cylinder, 6 litre engine. Its premium design features provide economic and durable operation offering the ideal characteristics for electrical power generation.

Engine Speed (rev/min)	Type of Operation	Typical Generator Output (Net)		Engine Power			
				Gross		Net	
		kVA	kWe	kWm	bhp	kWm	bhp
1500	Prime Power	150.0	120.0	136.8	183.4	129.3	173.3
	Standby Power	165.0	132.0	150.5	201.7	143.0	191.7

All ratings data based on operating under ISO/TR 14396/ISO 8528 conditions using typical fan sizes and drive ratios. For operation outside of these conditions please consult your Perkins contact. Performance tolerance quoted by Perkins is +5%.

Electrical ratings assume a power factor of 0.8 and a generator efficiency of 90%.

Fuel specification: BS 2869 Part 2 1998 Class A2 or ASTM D975 D2

Lubrication oil: A single or multigrade oil to ACEA/E1 E2 or API CD/SD

Rating Definitions

Prime Power: Power available at variable load in lieu of main power network. An overload of 10% is permitted for 1 hour in every 12 hours of operation.

Standby Power: Power available at variable load in the event of a main power network failure. No overload is permitted.

All information in this document is substantially correct at time of printing and may be altered subsequently

Publication No. 1793/11/08 Produced in England ©2005 Perkins Engines Company Limited

1000 Series

1006TAG2

Standard ElectropaK Specification

Air inlet

- Mounted air filter and turbocharger

Fuel System

- Rotary fuel injection pump
- Electronic governor – speed control to BS 5514 Class A0, ISO 3046-4M3
- Twin spin-on full flow fuel filters and pre-filter

Lubrication system

- Flat bottomed aluminium sump
- Twin spin-on full flow oil filters
- Oil cooler

Cooling system

- Thermostat controlled cooling system with gear driven water pump
- 25" belt-driven pusher fan and guards
- Radiator incorporating air-to-air charge cooler and piping

Electrical system

- 12 volt starter motor and 55 amp alternator with DC output
- 12 volt oil pressure and coolant temperature switches
- 12 volt shut down solenoid – energised to run cold start aid

Flywheel and housing

- Cast iron SAE 3 flywheel housing
- High inertia flywheel to SAE J620 size 10/11½

Mountings

- Front engine mounting bracket

Optional Equipment

- 24 volt alternator
- 24 volt starter motor
- Water temperature gauge and sender
- Heater/Starter switch
- Rear engine mountings
- Workshop manual
- Parts book
- User handbook

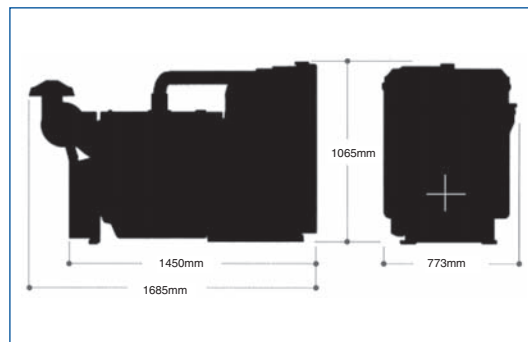

General Data

Number of cylinders	6
Cylinder arrangement	Vertical in-line
Cycle	4 stroke
Induction system	Turbocharged, air-to-air aftercooled
Combustion system	Direct injection
Cooling system	Water-cooled
Bore and stroke	100 x 127 mm
Displacement	5.99 litres
Compression ratio	17.0:1
Direction of rotation	Anti-clockwise, viewed on the flywheel
Total lubrication system capacity	19 litres
Coolant capacity (inc. radiator)	41 litres
Length	1685 mm
Width	773 mm
Height	1065 mm
Total weight (dry)	690 kg

Overall dimensions and weight will depend on final specification.§§

Fuel consumption litres/hour (UK gallons/hour)	
Power Rating %	1500 rev/min
110	45.0 (9.9)
100	41.0 (9.0)
75	31.0 (6.8)
50	20.0 (4.4)



Perkins Engines Company Limited

Peterborough PE1 5NA
 United Kingdom
 Telephone +44 (0)1733 583000
 Fax +44 (0)1733 582240
www.perkins.com

Distributed by