

CHV160 High Performance Frequency Inverter for Water Supply

Operation Manual



Safety Caution

Please read this operation manual carefully before installation, operation, maintenance or inspection.

In this manual, the safety cautions were sorted to “warning” or “caution”.



Warning

Warning indicates death, severe personal injury or property damage can result if proper precautions are not taken.



Caution

of any

Caution indicates that minor personal injury or material damage can result if proper precautions are not taken. This sign is also used for alert

un-safety operation.

In some cases, the comments in “Caution” could cause serious accident, please follow the important precautions in any situation.

★ **NOTE** Note is the necessary step to ensure proper operation.

Warning Marks were shown on the front panel of inverters.
Please follow these indications when using the inverter.

WARNING
<ul style="list-style-type: none">● May cause injury or electric shock.● Please follow the instructions in the manual before installation or operation.● Disconnect all power line before opening front cover of unit. Wait at least 1 minute until DC Bus capacitors discharge.● Use proper grounding techniques.● Never connect AC power to output UVW terminals

Table

1.	General Description	4
1.1	General Technology Features	4
1.2	Explanation of data plate	5
1.3	Selection Guide	5
1.4	Explanation of each part of inverter	6
1.5	Explanation of Extension Card	7
1.6	External Dimension	8
1.7	Braking Unit	8
2.	Unpacking Inspection	10
3.	Disassembly and Installation	11
3.1	Environmental Conditions for inverter Operation	11
3.2	Interval Distance of Inverter Installation	12
3.3	Installation Dimensions of External Keyboard	13
3.4	Cover Disassembly and Installation	14
3.5	Disassembly and Installation of Extension Card	14
4.	Wiring	15
4.1	Wiring Diagram of Peripheral Equipment	16
4.2	Connecting Terminal Diagram	17
4.3	Typical Wiring Diagram	18
4.4	Specification Table of Breaker, Cable and Contactor	19
4.5	Wiring of Main Circuit	19
4.6	Control Circuit Connection	22
4.7	Installation Guide Based On EMC Requirements	23
5.	Operation	27
5.1	Operating Panel Description	27
5.2	Operation Process	28
5.3	Running State	33
5.4	Quick Testing	35
6.	Detail Function Description	36
7.	Failure Inspection and Elimination	84
7.1	Failure Information and Elimination	84
7.2	common failures and solutions	85
8.	Maintenance	87
8.1	Daily Maintenance	87
8.2	Schedule Maintenance	87
8.3	Replacement of wearing parts	87
8.4	Warranty	88

1. General Description

1.1 General Technology Features

• Input & Output

- ◆ Input Voltage Range: 380/220V±15%
- ◆ Input Frequency Range: 47~63Hz
- ◆ Output Voltage Range: 0 ~ Rated voltage
- ◆ Output Frequency Range: 0~600Hz

• External Interface

◆ Programmable Digital Input: 6 channel inputs, one of them could be used as high speed pulse input, another 4 channel inputs can be extended by I/O card.

◆ Programmable Analog Input: AI1: 0~10V input, AI2: 0~10V or 0~20mA input, extension card can offer another 2 inputs.

◆ Open Circuit Collector Output: 1 channel output, extension card can offer another one.

◆ Relay Output: 2 channel outputs, extension card can offer another one.

◆ Analog Output: 1 channel output (could be extended to 2 channels), 0/4~20mA or 0/2~10V selectable.

• Technology Features

◆ Control Mode: V/F Control

◆ Overload Capacity: 150% rated current 60 seconds; 180% rated current 10 seconds.

◆ Carrier Frequency: 1.0K~16.0KHz; adjustable automatically according to the temperature and load features.

• Function Features

◆ Frequency Setting Mode: Digital Setting, Analog Setting, Pulse Frequency Setting, Serial Communication Setting, Multi-Speed and Easy PLC Setting, PID Setting, etc. The frequency setting mode can be switched between presetting combination and mode.

◆ PID Control Function

◆ Easy PLC, Multi-Speed Control Function: 16-speed Control

◆ Traverse Control Function

◆ Length and Time Control Function

◆ Non-Stop Function while instantaneous power failure

◆ Speed pick-up Function: Smoothly start the running motor

◆ QUICK/JOG Function: Multi-function shortcut key defined by user

◆ Automatic Voltage Adjustment Function: Keep static output voltage automatically when mains voltage fluctuating.

◆ Up to 27 functions for failure protection: over current, over voltage, under voltage, over temperature, phase failure, over load etc.

1.2 Explanation of data plate

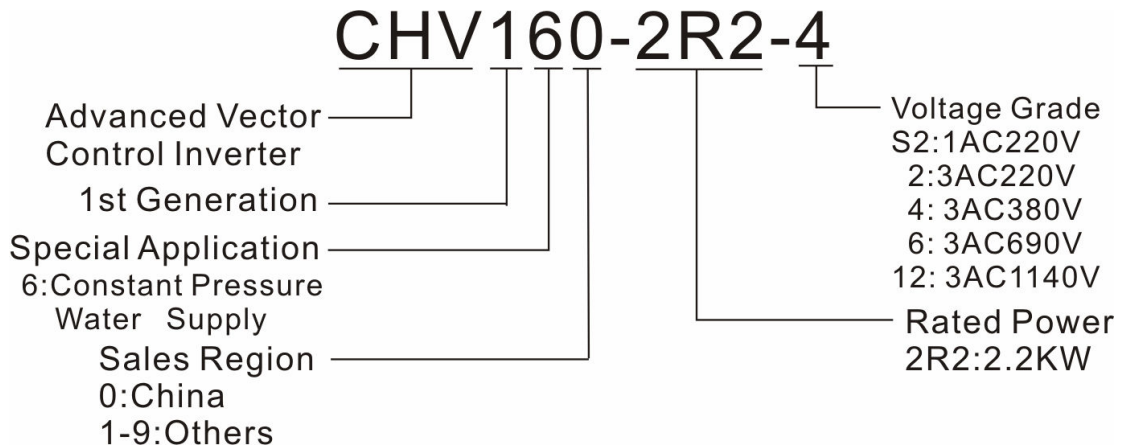

Figure 1-1. Inverter data plate

1.3 Selection Guide

Power Voltage: 3AC 380V -15%~15%

Model No.	Rated Output Power(KW)	Rated Input Current(A)	Rated Output Current(A)	Size
CHV160-5R5-4	5.5	15	13	C
CHV160-7R5-4	7.5	20	17	D
CHV160-011-4	11	26	25	D
CHV160-015-4	15	35	32	D
CHV160-018-4	18.5	38	37	E
CHV160-022-4	22	46	45	E
CHV160-030-4	30	62	60	E
CHV160-037-4	37	76	75	F
CHV160-045-4	45	90	90	F
CHV160-055-4	55	105	110	F
CHV160-075-4	75	140	150	G
CHV160-090-4	90	160	176	G
CHV160-110-4	110	210	210	G
CHV160-132-4	132	240	250	H
CHV160-160-4	160	290	300	H
CHV160-185-4	185	330	340	H
CHV160-200-4	200	370	380	I
CHV160-220-4	220	410	415	I
CHV160-250-4	250	460	470	I
CHV160-280-4	280	500	520	I
CHV160-315-4	315	580	600	I

Power voltage: 3AC 220V -15%~15%

Model No.	Rated Power(kW)	Rated Input Current(A)	Rated Output Current(A)	Size
CHV160-004-2	4	17	16	D
CHV160-5R5-2	5.5	21	20	D
CHV160-7R5-2	7.5	31	30	E
CHV160-011-2	11	43	42	E
CHV160-015-2	15	56	55	E
CHV160-018-2	18.5	71	70	F
CHV160-022-2	22	81	80	F
CHV160-030-2	30	112	110	G

Model No.	Rated Power(kW)	Rated Input Current(A)	Rated Output Current(A)	Size
CHV160-037-2	37	132	130	G
CHV160-045-2	45	163	160	G

1.4 Explanation of each part of inverter

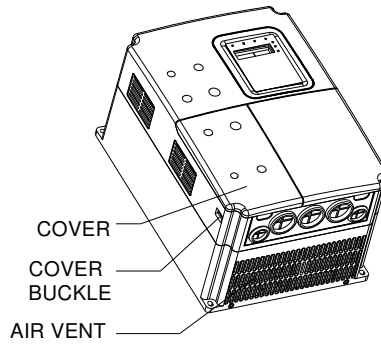
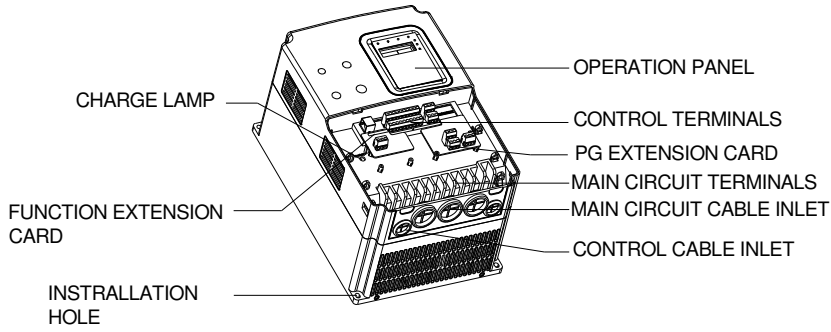
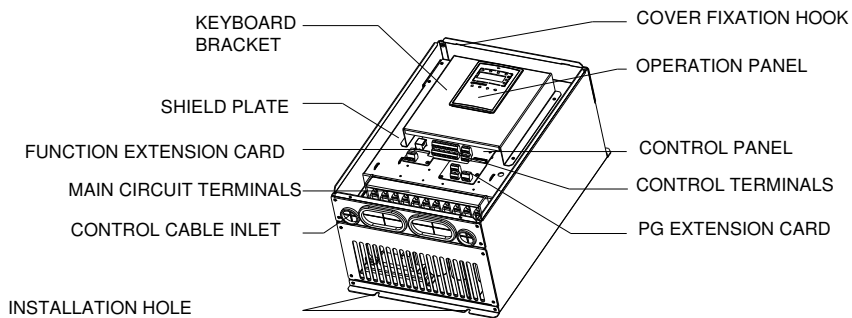

Figure 1-2. Each Parts of inverter for 15kw and below with plastic case



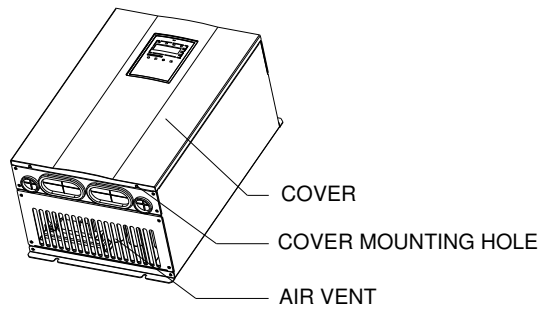

Figure 1-3. Each Parts of inverter for 18.5kw and above with metal case

1.5 Explanation of Extension Card

Adopting the advanced modularization design, CHV series inverters are custom design products which could lower the customer's purchasing cost efficiently. In the mean time, we offer an open re-development platform to make the clients realize their private function easily.

Extension Card	Function Explanation
Serial Communication Interface Card	Offer RS232 and RS485 dual physical communication interface 1. RS232 adopts standard D9 master seat. 2. 3-hole RS485 interface, two communication mode can be switched by jumper. 3. Build-in MODBUS RTU standard communication protocol.
Injection Moulding Card	Suitable for Plastic Injection Machine application, including signal conversion. Realize special frequency setting function.
Tension Control Card	Offer professional solution for tension control application.
Water Supply Control Card	Realize functions such as constant pressure water supply, multi pumps automatic switch, sleeping, timing, etc,
I/O Extension Card	Offer more input/output terminals; enhance the inverter's external function.

Please refer to the extension card manual for detail.

1.6 External Dimension

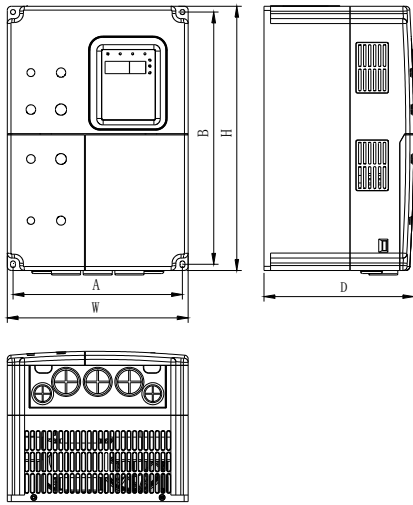

Figure 1-4. External Dimension for 15kw and below

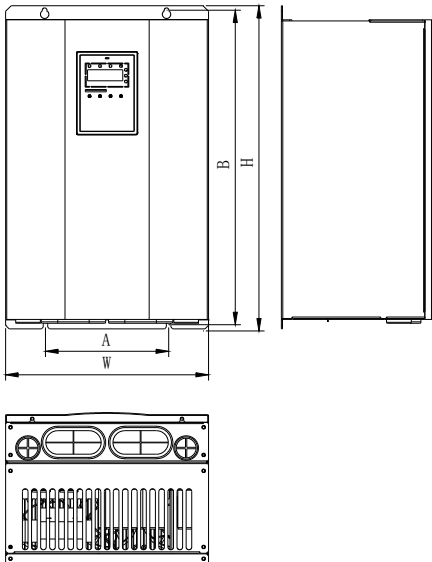

Figure 1-5. External Dimension for 18.5kw and above
External and Installation Dimension

Capacity (KW)	Size	A (mm)	B (mm)	H(mm)	W(mm)	D(mm)	Installation Hole(mm)
		Installation Dimension		External Dimension			
4~5.5	C	147.5	237.5	250	160	180	5.2
7.5~15	D	206	305.5	320	220	180	6.0
18.5~30	E	177.2	455.7	467	290	215	6.5
37~55	F	230	564.5	577	375	270	7.0
75~110	G	320	738.5	755	460	330	9.0
132~185	H	270	1233	1180	490	390	13.0
200~315	I	500	1326	1264	750	400	13.0

1.7 Braking Unit

CHV series inverter($\leq 15\text{KW}$) has built-in braking unit. Inverter($\geq 18.5\text{KW}$) do not have built-in braking unit. Please select proper braking unit according to inverter power range. For

the application whose braking torque is 100% and braking unit usage rate is 10%, selection guide of braking unit and braking resistor is as following table.

1.7.1 Selection guide of braking unit and resistor under 200V voltage

Inverter Power (KW)	Braking Unit		Braking resistor(100% braking torque)	
	Model No.	Quantity	Model No.	Quantity
4.0	Built-in	1	40Ω/390W	1
5.5	Built-in	1	30Ω/520W	1
7.5	Built-in	1	20Ω/780W	1
11	B5-052	1	13.6Ω/2400W	1
15	B5-052	1	10Ω/3000W	1
18.5	B5-052	1	8Ω/4800W	1
22	B5-052	1	6.8Ω/4800W	1
30	B5-052	1	5Ω/6000W	1
37	B5-052	1	5Ω/6000W	1
45	B5-052	1	3.4Ω/9600W	1
55	B5-052	1	3.4Ω/9600W	1
75	B5-062	2	5Ω/6000W	2

1.7.2 Selection guide of braking unit and resistor under 400V voltage

Inverter Power (KW)	Braking Unit		Braking resistor(100% braking torque)	
	Model No.	Quantity	Model No.	Quantity
5.5	Built	1	100Ω/520W	1
7.5	Built	1	75Ω/780W	1
11	Built	1	50Ω/1040W	1
15	Built	1	40Ω/1560W	1
18.5	B5-054	1	32Ω/4800W	1
22	B5-054	1	27.2Ω/4800W	1
30	B5-054	1	20Ω/6000W	1
37	B5-054	1	16Ω/9600W	1
45	B5-054	1	13.6Ω/9600W	1
55	B5-054	1	10Ω/12000W	1
75	B5-064	1	6.8Ω/12000W	1
90	B5-064	1	6.8Ω/12000W	1
110	B5-064	1	6.8Ω/12000W	1

2. Unpacking Inspection



CAUTION

- **To avoid dangerous of injury, don't install or operate any damaged inverter or any inverter with damaged components.**



Please do the following inspection after unpacking and taking out the inverter,

1. Ensure there is no any damage during transportation (any damage, break up or nick on the machine body).
2. Ensure there is operation manual and warranty card in the packing box.
3. Ensure the data plate that it is the one you ordered.
4. Ensure the optional parts are what you need if you ordered any optional parts.

Please contact the local agent if there is any damage of inverter or optional parts.

]

3. Disassembly and Installation

 Warning
<ul style="list-style-type: none"> ● Any untrained person working on any parts/systems of inverter or any rule in the “Warning” being violated, will cause severe personal injury or property damage. Only licensed person, who has been trained on design, installation, commissioning and operation of inverter, is permitted to operate this equipment. ● Input power cable must be connected securely and perpetually, and the equipment must be grounded securely. ● Even if the inverter is not in operation, following terminals can still have dangerous voltage: <ul style="list-style-type: none"> - R、S、T Power Supply Terminal R, S, T - Motor Connection Terminal U, V, W ● The installation of inverter can not be started until it is electrically discharged after the power supply is switched off for 5 minutes. ● The grounding conductor should have a section area equal to or larger than that of power supply cable.
 Caution
<ul style="list-style-type: none"> ● Lift the cabinet by its base; do not lift it by holding on its panel when moving the inverter, otherwise its main unit could be falling off, causing personal injury. ● The inverter should be mounted on top of fireproofing material (for instance, metal), otherwise, fire could be caused. ● When it is required that two inverters be installed inside one cabinet, cooling fan should be installed with and control the air temperature lower than 45°C, otherwise it could cause fire or damage the device.

3.1 Environmental Conditions for inverter Operation

3.1.1 Temperature

Operating atmosphere temperature: -10°C - +40°C, derated the inverter when operating at temperature higher than 40°C.

3.1.2 Humidity

Relative air humidity ≤ 90%, without dewfall

3.1.3 Altitude

If installed at altitude lower than 1000m, the inverter can output its rated power. If installed at altitude higher than 1000m, the inverter’s output will be reduced. For details of its output vs. altitude, please refer to the following figure:

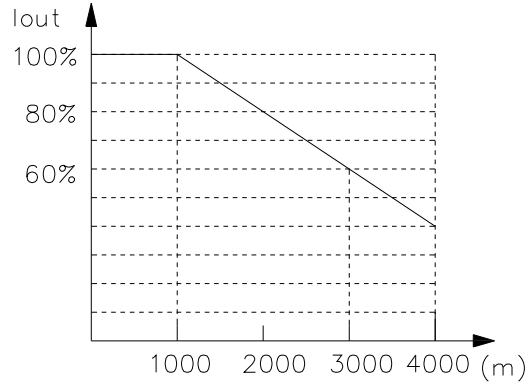

Figure 3-1 Installation Site Altitude

3.1.4 Impact and Vibration

It is not allowed that the inverter falls down to the ground or suffers from fierce impact, or installed at the site which may have often vibration.

3.1.5 Electromagnetic Radiation

The inverter is not allowed to be installed at site close to electromagnetic radiation source.

3.1.6 Water

It is not allowed that the inverter is installed at site where water tricking or dewfall may happens.

3.1.7 Air Pollution

The inverter is not allowed to be installed at site which has air pollution such as dusty, corrosive gas environment.

3.2 Interval Distance of Inverter Installation

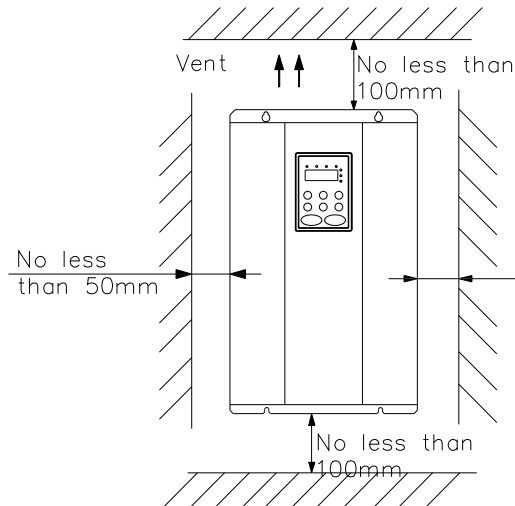

Figure 3-2 Installation Distance for Insulation

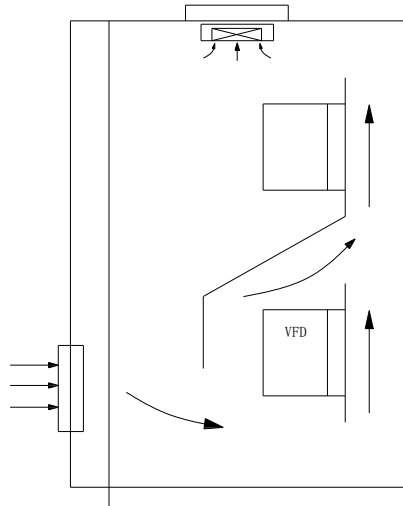

Figure 3-3 Installation of Multiple Inverters

When one inverter is installed on top of another one, one air deflector should be added between them.

3.3 Installation Dimensions of External Keyboard

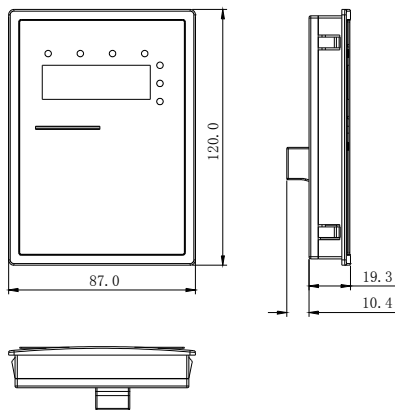

Figure 3-4 Installation Dimensions of External Panel
Dimensions for External Panel

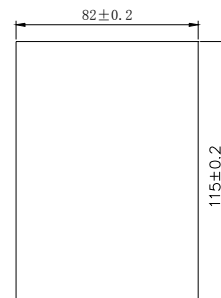

Figure 3-5 Position

3.4 Cover Disassembly and Installation

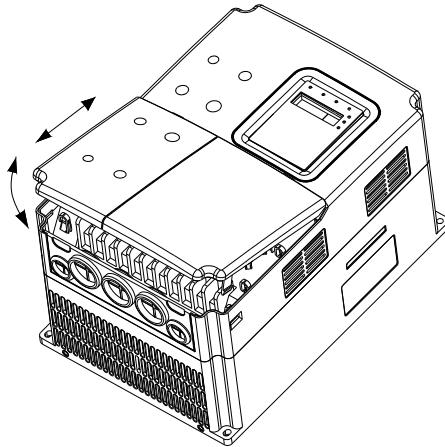

Figure 3-6 Disassembly and Installation of Plastic Cover

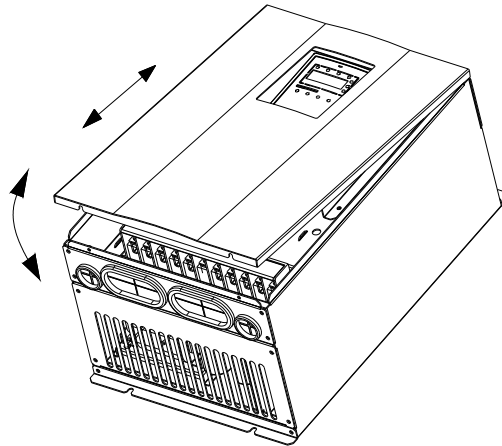

Figure 3-7 Disassembly and Installation of Metal Plate Cover

3.5 Disassembly and Installation of Extension Card

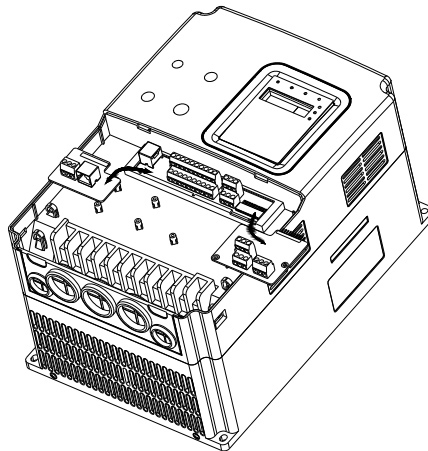

Figure 3-8 Disassembly and Installation of Extension Card

4. Wiring



WARNING

- In order to ensure the safety operation of inverter, it must be connected by licensed electric technicians.
- It is forbidden to use high voltage insulation testing devices to test the insulation of cable which is connecting the inverter.
- Even if the inverter is not in operation, DC terminals and motor terminals could still have dangerous voltage. Therefore, any work can not be started until it is electrically discharged after the power supply has been switched off for 5 minutes.
- The inverter's grounding terminals must be connected to the ground securely.
 - The grounding resistance of voltage class 200V is 100Ω or less
 - The grounding resistance of voltage class 400V is 10Ω or less
 - The grounding resistance of voltage class 660V is 50Ω or lessOtherwise, there is a risk of causing electric shock and fire.
- The input terminals (R, S, T) and output terminals (U, V, W) of inverter must be connected correctly, otherwise it will cause damage to devices inside the inverter.
- It is forbidden to wire and/or operate the inverter when your hands are wet; otherwise there is a risk of electric shock.



CAUTION

- Please verify the rated voltage of inverter is consistent to the voltage of AC power source.
- Power supply cables and motor cables must be connected securely and perpetually.

4.1 Wiring Diagram of Peripheral Equipment

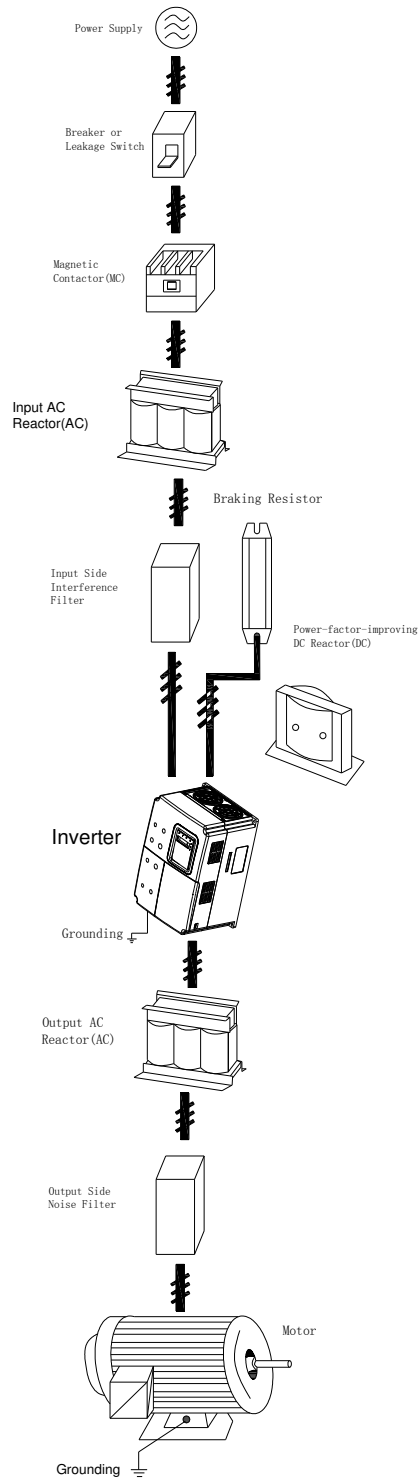

Figure 4-1 Wiring Diagram of Peripheral Equipment

4.2 Connecting Terminal Diagram

4.2.1 Main Circuit Terminals

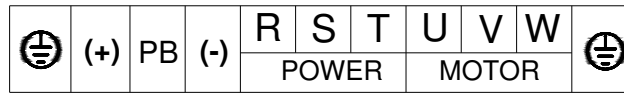

Figure 4-2 Main Circuit Terminals Diagram (15kw and below)

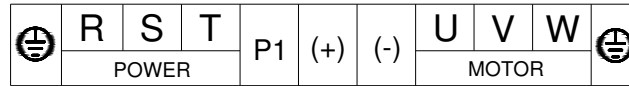

Figure 4-3 Main Circuit Terminals Diagram (18.5kw and above)

Function Description of Main Circuit Terminals:

Terminal Name	Function Description
R、S、T	3 phase power supply terminals
(+)、(-)	Spare terminals for external braking unit
(+)、PB	Spare terminals for external braking resistance
P1、(+)	Spare terminals for external DC reactor
(-)	Output terminals of DC negative bus bar
U、V、W	Output terminals of 3 phase AC
PE	Grounding Terminals

4.2.2 Control Circuit Terminals

S1	S2	S3	S4	S5	HDI1	GND	AI1	AI2	+10V	R01A	R01B	R01C
+24V	PW	COM	Y1	CME	COM	HDO	AO1	GND	PE	R02A	R02B	R02C

Figure 4-4 Terminal Diagram of Control Circuit

4.3 Typical Wiring Diagram

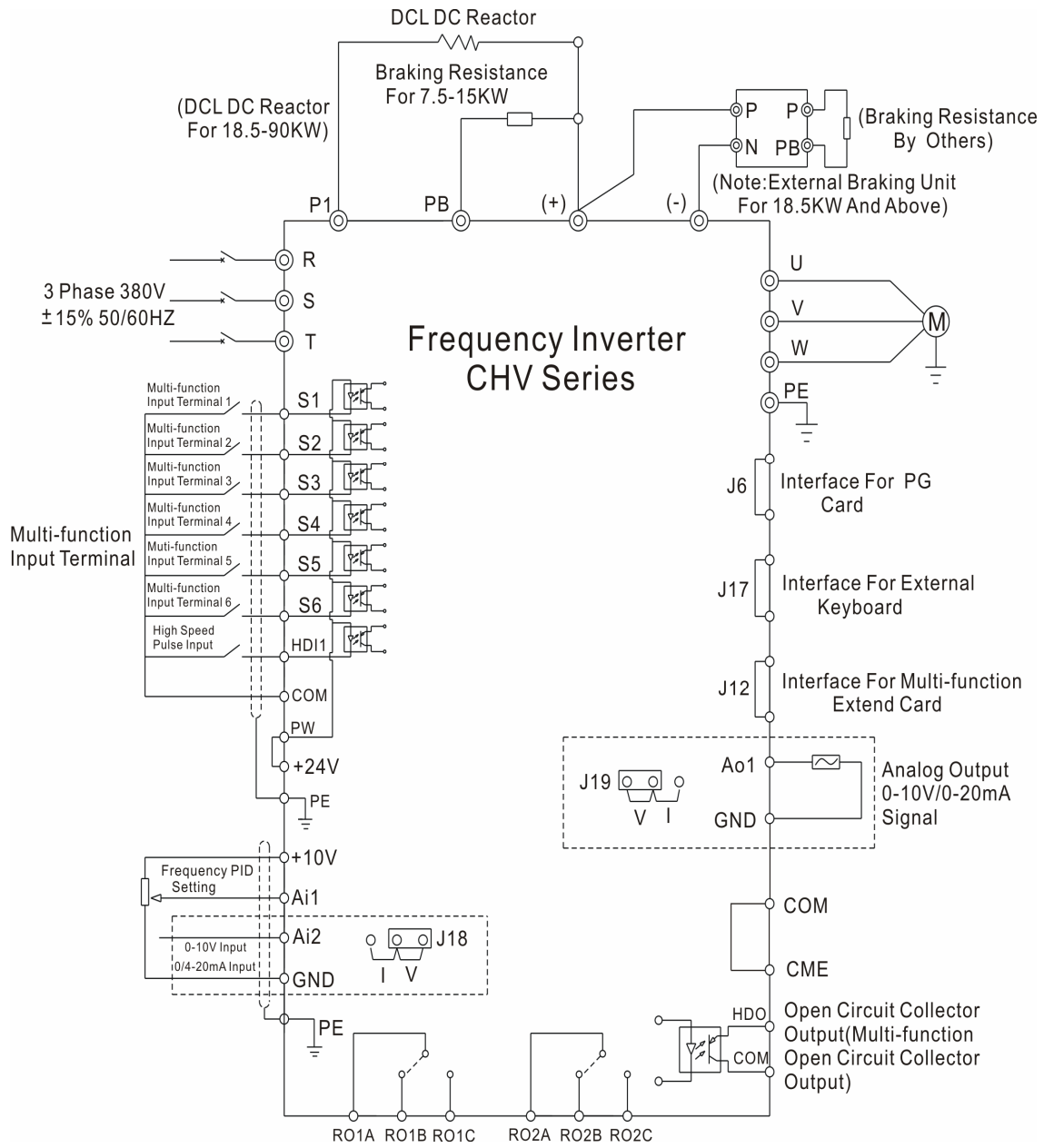

Figure 4-5 Standard Wiring Diagram

4.4 Specification Table of Breaker, Cable and Contactor

Model No.	Circuit Braker (A)	Input/Output copper wire	Contactor rated current(A)(380V or 220V)
CHV160-004G-2	40	6	25
CHV160-5R5G-2	63	6	32
CHV160-7R5G-2	100	10	63
CHV160-011G-2	125	25	95
CHV160-015G-2	160	25	120
CHV160-018G-2	160	25	120
CHV160-022G-2	200	35	170
CHV160-030G-2	200	35	170
CHV160-037G-2	200	35	170
CHV160-045G-2	250	70	230
CHV160-5R5G-4	25	4	16
CHV160-7R5G-4	40	6	25
CHV160-011G-4	63	6	32
CHV160-015G-4	63	6	50
CHV160-018G-4	100	10	63
CHV160-022G-4	100	16	80
CHV160-030G-4	125	25	95
CHV160-037G-4	160	25	120
CHV160-045G-4	200	35	135
CHV160-055G-4	200	35	170
CHV160-075G-4	250	70	230
CHV160-090G-4	315	70	280
CHV160-110G-4	400	95	315
CHV160-132G-4	400	150	380
CHV160-160G-4	630	185	450
CHV160-185G-4	630	185	500
CHV160-200G-4	630	240	580
CHV160-220G-4	800	150x2	630
CHV160-250G-4	800	150x2	700
CHV160-280G-4	1000	185x2	780
CHV160-315G-4	1200	240x2	900

4.5 Wiring of Main Circuit

4.5.1 Power Supply Connection of Main Circuit

4.5.1.1 Breaker

Between 3ph AC power supply and power input terminals (R, S, T), it is necessary to connect a breaker which is compatible with the capacity of inverter. The capacity of breaker is 1.5-2 times to the rated current (amperage) of inverter. For details, please refer to **Specification Table of Breaker, Cable, and Contactor**

4.5.1.2 Magnetic Contactor

In case of system malfunction and that the power input of inverter must be cut off completely for safety, magnetic contactor can be installed at the power input side to control the on/off of the main circuit power supply.

4.5.1.3 Input AC Reactor

In case of high voltage input from power grid and so heavy current flowing into power supply circuit damages components of rectifier, it is necessary to install and connect a AC

reactor in the input side, which can also improve the power factor of input side.

4.5.1.4 Noise Filter at Input Side

As inverter in operation can produce interference to nearby equipment through its cables, noise filter can be used to minimize this interference, as shown in following diagram.

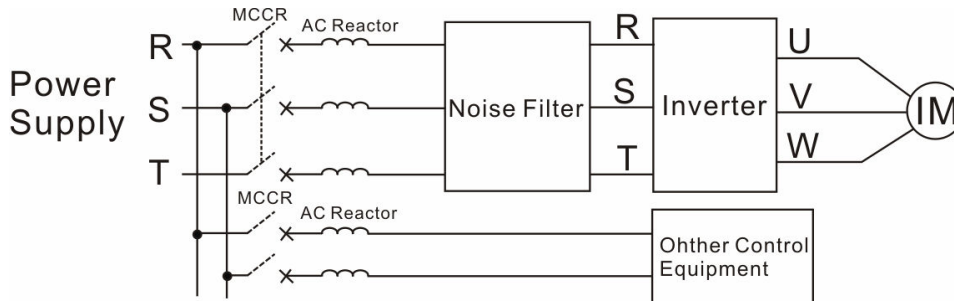

Figure 4-6 Wiring Diagram at Power Supply Side of Main Circuit

4.5.2 Wiring at inverter Side of Main Circuit

4.5.2.1 DC Reactor

CHV series (larger than 15KW) has built-in DC reactor which can improve power factor, and prevent rectifier damage because of excessively heavy current input to the inverter which is installed with a large size transformer, and as well prevent rectification circuit damage caused by sudden variation of power grid voltage or harmonic wave generated by phase control overloading.

4.5.2.2 Braking Unit and Braking Resistor

- CHV inverter of 15kW and below has braking unit installed inside. In order to release the feedback energy generated during braking, braking resistor must be installed and connected at the (+) and PB terminal.

- Braking resistance should have a wire length less than 5M.

- As braking resistor can release energy and increase the temperature, safety protection and good ventilation should be provided when the braking resistor is being installed.

- CHV inverter of 18.5kW or higher has external braking unit. In order to release the feedback energy generated during braking, braking units must be installed and connected at (+) and (-) terminals, and braking resistor must be installed and connected at the (+) and PB terminals.

- The wire connecting (+), (-) terminals of inverter and (+), (-) terminals of braking unit should have a length less than 5 meters. The wire for (+), PB terminals of braking unit and braking resistor should have a length less than 10 meters.

Caution: Be sure of electric polarity of (+), (-), and DO NOT misconnect them; it is not allowed to directly connect (+), (-) terminals to braking resistor, otherwise there will be a risk of inverter damage or fire.

4.5.3 Wiring at Motor side of Main Circuit

4.5.3.1 Output Reactor

In the case that the distance between inverter and motor is more than 100 meters, as long cable can have parasitic capacitance to ground and cause large current leakage, so the inverter will have frequent over-current protection, it is necessary to add output reactor to compensate this fact, and in the meantime to avoid damage to motor insulation.

4.5.3.2 Noise Filter at Output Side

Noise filter installed at the output side can minimize current leakage at the connecting wire and the wireless noise caused by cable between inverter and motor. Its Connection is shown in following diagram.

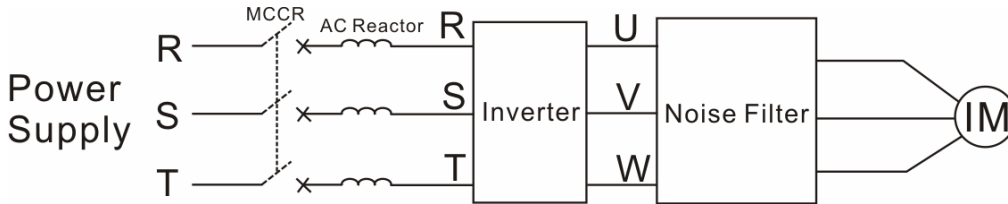

Figure 4-7 Wiring Diagram at Motor Side of Main Circuit

4.5.4 Feedback Unit Wiring

Feedback unit can feed back the electricity generated by regenerative braking of motor to the grid. CHV feedback unit uses IGBT as the rectification feedback, which, if compared with traditional 3 phase inverse parallel bridge-type rectification unit, has an allocation of feedback harmonic wave distortion less than 4% of first harmonic, and thus causes less pollution to the grid. Feedback unit is extensively used at oil field for pumping unit, centrifugal machine and hoister and so on.

4.5.5 Wiring of common DC bus

For multiple motors application for paper manufacturing machinery and chemical fiber industry, common DC bus is normally used. At any time, some motors are in operating condition while some others are at regenerative braking (generating electricity) condition. In this case the regenerated electricity is automatically balanced at the DC bus, and can be supplied to motors at operating condition, reducing the electricity consumption of the whole system from the grid, more energy saving than traditional single inverter for single motor. Its wiring diagram is shown as following figure:

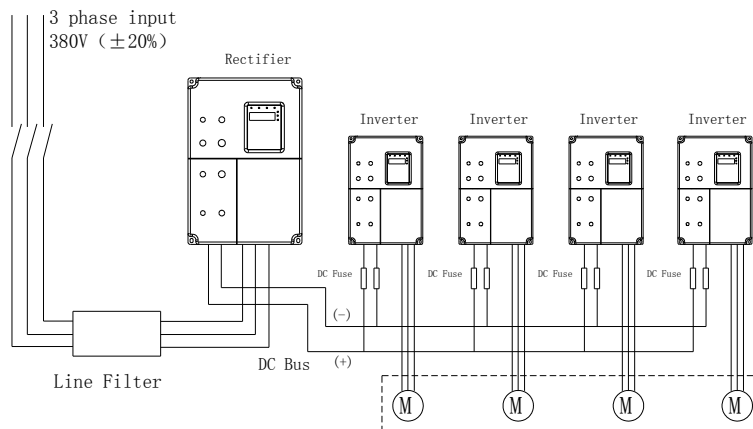
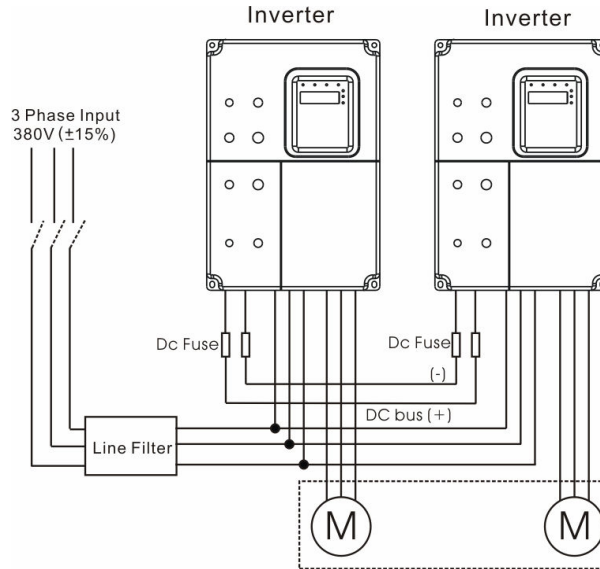

Figure 4-8 Wiring of common DC bus

When two motors are at operation at the same time (such as windin motor、unreeling motor). In this case the DC buses of the two inverters can be connected in parallel so that the regenerated electricity can be supplied to motors at electromotion to save energy. Its detail wiring is shown as following figure:



Wiring of Common DC Bus

4.5.6 Ground Connection (PE)

。 In order to ensure safety and prevent electrical shock and fire, inverter’ s ground terminals PE must be earth connected with ground resistance less than 10Ω. As earth wire should be big and short, it is better to use wire with multiple copper core. When multiple inverters need to be earth connected, it is suggested for them as many as possible not to use common earth wire to prevent the earth wire looping in.

4.6 Control Circuit Connection

4.6.1 Precautions

Please use multiple core shielding cable or shield twisted pair (STP) to connect the control terminals. The shielding cable should be connected with the inverter earth terminals PE if it is applied at the inverter side. The wire arrangement should make sure that control cables are more than 20cm far away from the main circuit and heavy current circuits (including power supply cable, motor cable, relay and contactor connecting cable), and parallel arrangement should be avoided. It is suggested to apply perpendicular arrangement to prevent inverter malfunction caused by external interference.

4.6.2 Control Panel Terminals

Terminal Name	Description
S1~S5	Switching Signal Input Terminals, and together with PW and COM forms Optical Coupling isolation input Input Voltage Range: 9~30V Input Impedance: 3.3KΩ
HDI1 (HDI2)	High speed pulse or switching signal Input, and together with PW and COM forms Optical Coupling isolation input Pulse input frequency range: 0~50KHz Input Voltage Range: 9~30V

Terminal Name	Description
	Input Impedance: 1.1K Ω
PW	External power supply. Customers can directly connect it to external power supply (between itself and COM), or use the +24V power supplied by the inverter itself. It is factory set up that the +24 is short connected to PW. Therefore, when external power supply is to be used, PW should be disconnected to +24V.
+24V	+24V power supply for the inverter itself. Maximum Output Amperage: 150mA
COM	The common terminal of +24V or external power supply
AI1 (AI3, AI4)	Analog Input, with voltage range: 0~10V Input Impedance: 10K Ω
AI2	Analog Input, with voltage range (0~10V) /Amperage (0~20mA) selective by means of J18 Input Impedance: 10K Ω (Voltage Input) /250 Ω (Amperage Input)
+10V	+10V power supply for the inverter itself
GND	Reference zero potential for +10V. (Note: GND is isolated from COM)
Y1 (Y2)	Open circuit collector output terminal. Its corresponding common terminal is CME External Power Voltage Range: 0~24V Output Current Range: 0~50mA
CME	common terminal of open circuit collector output
HDO	High speed pulse output terminal. Its corresponding common terminal is COM Output frequency range: 0~50 KHz
AO1 (AO2)	Analog output terminal, with selective voltage and amperage by means of jumper J19 Output Range: voltage (0~10V) /current (0~20mA)
PE	Grounding Terminal
RO1A, RO1B, RO1C	RO1 relay output, RO1A common terminal, RO1B normal-close, RO1C normal-open Contact rating: AC250V/3A, DC30V/1A
RO2A, RO2B, RO2C	RO2 relay output, RO2A common terminal, RO2B normal-close, RO2C normal-open Contact rating: AC250V/3A, DC30V/1A
RO3A, RO3B, RO3C	RO3 relay output, RO3A common terminal, RO3B normal-close, RO3C normal-open Contact rating: AC250V/3A, DC30V/1A

4.7 Installation Guide Based On EMC Requirements

4.7.1 General Description of EMC

EMC is the abbreviation of electromagnetic compatibility, which means the device or system has the ability to work normally under electromagnetic environment, and it does not produce electromagnetic interference to any thing in this environment. EMC includes two subjects: electromagnetic interference and electromagnetic anti-interference.

According to the route of transmission, electromagnetic interference has two categories: conducted interference and radiated interference.

Conducted interference is the interference transmitted by conductor, and therefore, any conductor, such as wire, transmission line, inductor, capacitor and so on, is the transmission

channel of interference.

Radiated interference is the interference transmitted in electromagnetic wave manner, and the energy it transmits is inversely proportional to the square of distance.

Electromagnetic interference generation must have three conditions or called-as three essential elements: interference source, transmission channel and sensitive receiver, any of which is essential. Solutions for EMC are based on these three. For customers, as the fact the device is interference source or receiver, the solution for EMC should start at the transmission channel.

Different electric or electronic devices are manufactured based on different EMC standard or class, and have different EMC ability.

4.7.2 EMC Features of inverter

Inverters, like other electric or electronic devices installed in a power distribution system, is a electromagnetic interference source and a electromagnetic receiver as well. The operating principle of inverter determines that it can produce certain electromagnetic interference noise, and in order to ensure that it works reliably in certain electromagnetic environment, its design gives it certain ability of anti-interference. When it is in operation, its EMC features include:

4.7.2.1 Input current is normally nonsinusoidal wave, including plenty of higher harmonic waves which may produce electromagnetic interference, reducing grid power factor and increasing wire loss.

4.7.2.2 Output voltage is high frequency PWM wave, which can have effect on motor temperature increase, reducing motor service life and increasing current leakage which make the leakage protection device malfunction, and in the same time generating strong electromagnetic interference and having effect on reliability of other electric devices.

4.7.2.3 As an electromagnetic receiver, receiving too strong interference from outside can make inverter malfunction or even damaged.

4.7.2.4 In system wiring, interference generated by inverter and its anti-interference supplement each other. The process reducing its interference from outside can increase its anti-interference ability.

4.7.3 EMC Installation Guide

In order for all electric devices in the same system to work reliably, this section, based on EMC features of inverter and for site installation reference, introduces its detail installation process on noise control, site wiring, grounding, leakage current and power supply filter application. Only these five jobs well done can derive good effective EMC.

4.7.3.1 Noise Control

The wires connected to all control terminals of inverter are shielding wires, which, at cable entry of inverter, connect the shielding layer to the ground at the nearest point by means of

360 trombone connection formed by cable clips. It is strictly prohibitive to twist the shielding layer into braid and to connect it to the ground of inverter, which greatly decreases the shielding effect and even lose the shielding effect.

The wires connecting the inverter and motor should be shielding wires or go through separated cable tray. The shielding layer of motor wires or one end of the metal shell of the cable tray should be connected to the ground and another end should be connected to the motor enclosure. In the meantime, installing a noise filter can reduce greatly the electromagnetic noise.

4.7.3.2 On-site Wire Arrangement

Power supply cable arrangement: the power supply cable of different control system is connected to the transformer independently. Normally it is 5 core wires, three of which are live wires, one of which is the neutral wire, and one of which is the earth wire. It is strictly prohibitive to the neutral and the earth wire is one wire.

Device categorization: Generally there are different electric devices contained in one control cabinet, such as inverter, electric wave filter, PLC and instrument and so on, which have different ability of emitting and withstanding electromagnetic noise. Therefore, it is necessary to categorize these devices into strong noise device and noise sensitive device. The same category devices should be installed at the same area, and the distance between different category devices should be more than 20cm.

Wire Arrangement inside the control panel: generally there are signal wire (light current) and power cable (strong current) in one cabinet. For the inverter, the power cables are categorized into incoming cable and outgoing cable. Signal wires can be easily interfered by power cables and thus make the equipment malfunction. Therefore, when wire arrangement, signal wires and power cables should be arranged in different area, it is strictly prohibitive to arrange them in parallel or interlacement at a close distance (less than 20cm), and even to tie them together. If the signal wires have to cross the power cables, they should be arranged in 90 angles. Power incoming cables and outgoing cables should not either be arranged in interlacement or tied together, especially for installing noise filter; otherwise the distributed capacitances of its incoming power cable and outgoing power cable can be coupling each other, consequently making it out of function.

4.7.3.3 Earth Connection

Inverter must be ground connected safely and securely when in operation. As it does not only ensure the safety of equipment and persons, but also is the simplest, most effective and lowest cost solution for EMC problem. Grounding is the top priority.

Grounding has three categories: exclusive pole grounding, common pole grounding, parallel earthwire grounding. Different control system should use exclusive pole grounding, and different devices in the same control system should use common pole grounding, and different devices connected by same power cable should use parallel earthwire grounding.

4.7.3.4 Leakage Current

Leakage current includes line-to-line leakage current and over-ground leakage current. Its

value depends on distributed capacitances and carrier frequency of the inverter. The over-ground leakage current, which is the current passing through the common earthwire, can flow into not only inverter system but also other equipment through earthwire, making residual current circuit breaker, relay or other devices malfunction. The value of line-to-line leakage current, which means the leakage current passing through distributed capacitors of input wire and output wire, depends on the carrier frequency of inverter, the length of motor cables and their section areas. The higher carrier frequency of inverter, the longer of the motor cable and/or the bigger cable section area, the heavier leakage current will occur.

Countermeasure

Decreasing the carrier frequency can effectively reduce the leakage current, and in the case of motor cable is relatively long (longer than 50m), it is necessary to install AC reactor or sinusoidal wave filter at the output side, and even longer, it is necessary to install one reactor at every certain distance.

4.7.3.5 Noise Filter

Noise filter has a great effect of electromagnetic decoupling, and so even if the optimal operation is fulfilled, it is preferred for customer to install it.

For inverter, noise filter has following categories:

- 1、 Noise filter installed at the input side of inverter
- 2、 Noise insulation for other equipment by means of isolation transformer or mains filter

5. Operation

5.1 Operating Panel Description

5.1.1 Panel Schematic Diagram

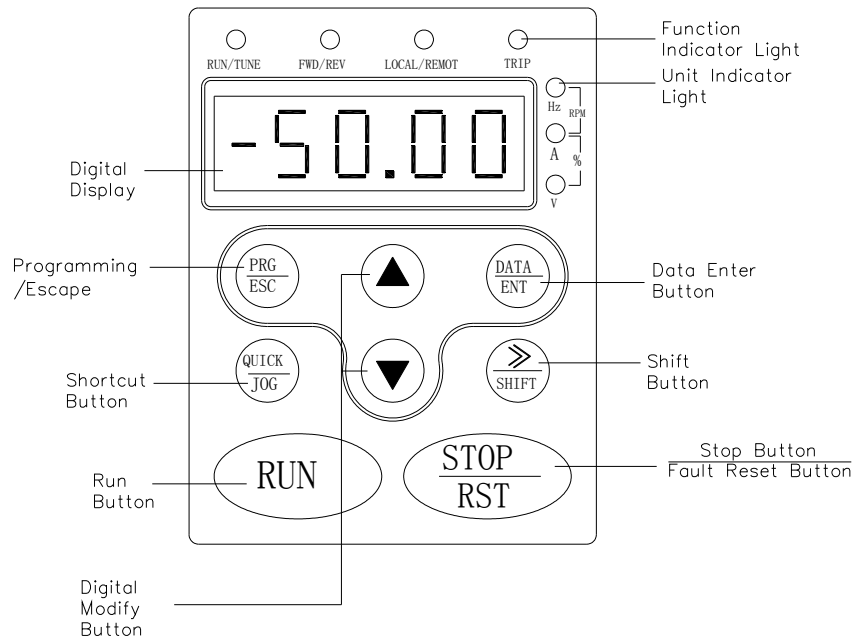



Figure 5-1 Operating Panel Schematic Diagram





5.1.2 Button Function Description

Button Symbol	Name	Function Description
	Programming Button	First-stage menu entry or exit and quick parameter delete
	Enter Button	Progressively enter menu to confirm parameters setting
	UP Increment Button	Progressive increase of data or function codes
	DOWN Decrement Button	Progressive decrease of data or function codes
	Shift Button	Under stop or operating display interface, can circularly select the parameters to display. When modify parameter, can select modified bit of the parameter
	Run Button	It is used for running under keyboard operating mode
	STOP/RESET Button	This button is for stop operation at operating state; This function code is restricted by P7.04. At fault alarm status, all control modes can use this button to achieve reset operation
	Shortcut Multifunction Button	This button function is determined by Function Code P7.03

Button Symbol	Name	Function Description
		0: QUICK function of shortcut menu for entering or exiting the first stage of shortcut menu 1: FWD/REV switching button to switch between forward and reverse 2: JOG button for Jog operation 3: clear UP/DOWN settings, clear the frequency set by UP/DOWN.
 + 	Combination	Pressing the RUN button and STOP/REST button at the same time can achieve inverter free-run stop

5.1.3 Indicator Light Description

1) Function Indicator Light Description

Indicator Light Name	Indicator Light Description
	Extinguished light indicates the inverter is at stop state; flickering light indicates the inverter is at parameters autotune state; bright light indicates the inverter is in operation.
	FWD/REV indicating light Extinguished light indicates forward operation state; bright light indicates reverse operating state.
	Indicator light for Keyboard operation, terminal control and remote communication control Extinguished light indicates being at keyboard control mode; flickering light indicates being at terminal control mode; bright light indicates being at remote communication mode.
	Overload pre-warning indicator light At overload pre-warning state, this light is flickering; at normal operation state, it is extinguished.

2) Unit Indicator Light Description

Hz A V RMP %

Hz frequency unit;

A current unit;

V voltage unit;

RMP rotation speed unit;

% percentage

3) Digital Display Area:

5 digit LED display, which can display all kinds of monitoring data and alarm codes such as set frequency, output frequency and so on.

5.2 Operation Process

5.2.1 Parameter Setting

Three stages of menu respectively are

1. Function code group number (The first-stage menu);
2. Function code label (the second-stage menu);

3. The set value of function code (the third-stage menu)

Remarks: when working at the third-stage menu, press Button **PRG/ESC** or Button **DATA/ENT** to return to the second-stage menu. The difference between both is: pressing Button **PRG/ESC** will save the set parameters into the control panel, and then return to the second-stage menu and also automatically shift to the next function code; pressing Button **DATA/ENT** will directly return to the second-stage menu without saving the parameters, and keep staying at the current function code.

For example: change the function code P1.01 setting from 00.00Hz to 01.05Hz

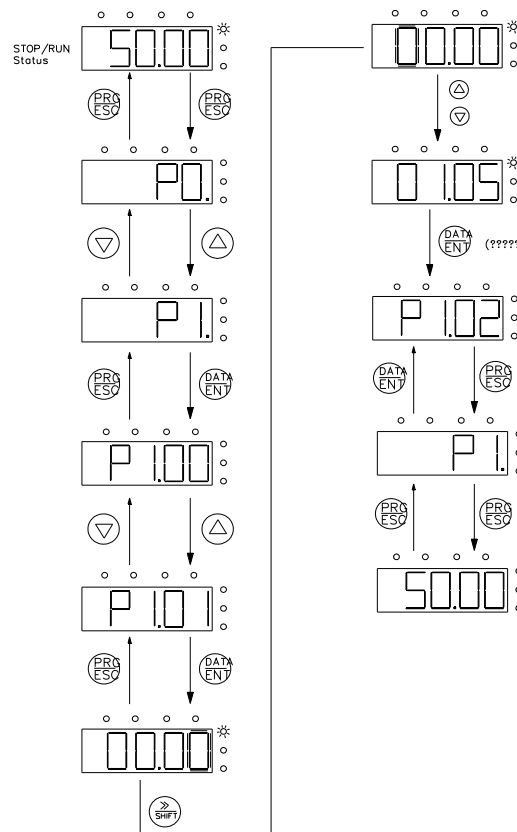

Figure 5-2 Third Stages Menu Operation Process Diagram

Under the third stages menu, if the parameter has no flickering bit, it means this parameter can not be modified. The possible reasons could be:

- 1) This parameter is unchangeable parameter, such as actual detected parameter, operation records and so on;
- 2) This parameter is un-modifiable under operating state, but modifiable at stop state

5.2.2 Shortcut Menu

Shortcut menu, in which often used parameters can be put, provides a quick way to view and modify function parameters. At the shortcut menu, a parameter being displayed as “hP0.11” means it is the function parameter P0.11. Modifying parameters at the shortcut menu has the same effect as doing at general programming state.

Maximum 16 function parameters can be put into the shortcut menu, and in the shortcut menu parameter can be added and deleted when the function code F7-03 is set as 0.

5.2.2.1 Add shortcut parameter: for instance, to set Function Code P0.00 as shortcut parameter can be done as follows:

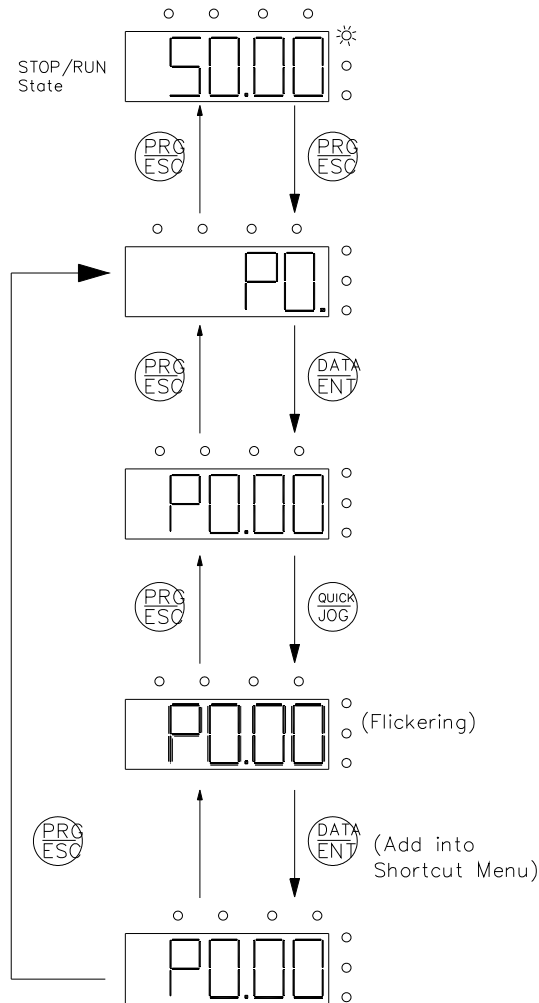

Figure 5-3 Example of Adding Parameter into Shortcut Menu

Remarks: If pressing Button **QUICK/JOG** under the programmable second menu, the display contents will be flickering, asking whether to save this parameter into the shortcut menu. If pressing Button **DATA/ENT** to confirm, the display contents will stop flickering, and the process is finished; if pressing Button **PRG/ESC** to cancel, the display contents will stop flickering, and the process is cancelled. If 16 parameters are fully added, "FULLP" will be displayed when trying to save more parameter into the shortcut menu.

5.2.2.2 Shortcut Parameter Operation

Shortcut menu has two stages menus, which are corresponding to the second and third menus of general programming method, and has no corresponding first menu.

Operation can be illustrated by following example:

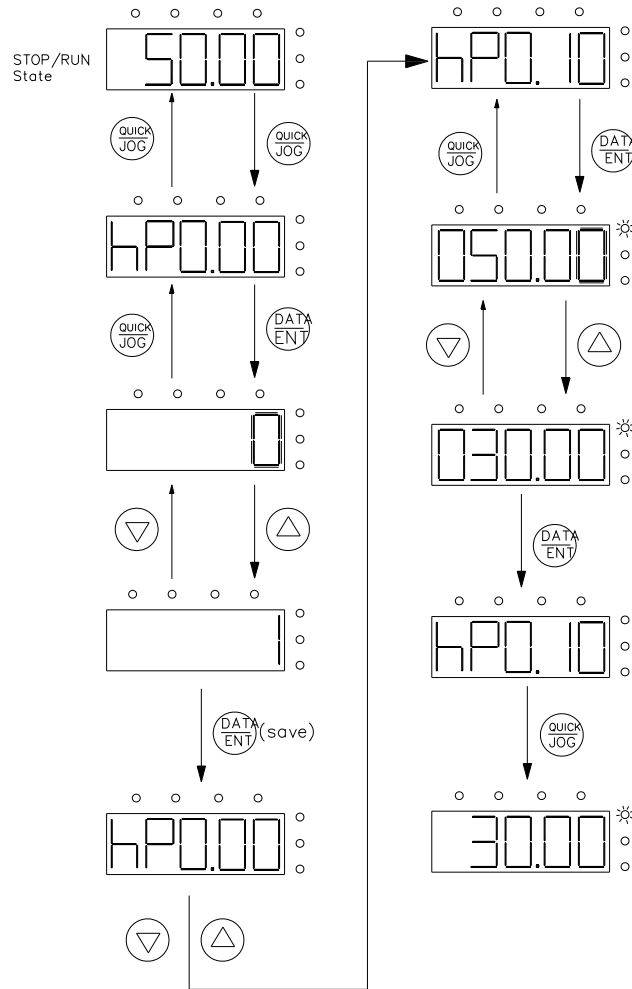

Figure 5-4 Shortcut Menu Operation Example

Remarks: Under stop or operating display interface, press Button **QUICK/JOG** to enter the shortcut second menu, use Button UP/DOWN to select different shortcut parameter, and then press **DATA/ENT** to enter the third menu. The method to modify parameter at the third menu is the same as that at the general third menu. If want to return to upper stage display, press Button **QUICK/JOG**.

“NULLP” being displayed when enter the QUICK second menu indicates the shortcut menu is empty.

5.2.2.3 Delete Shortcut Parameters:

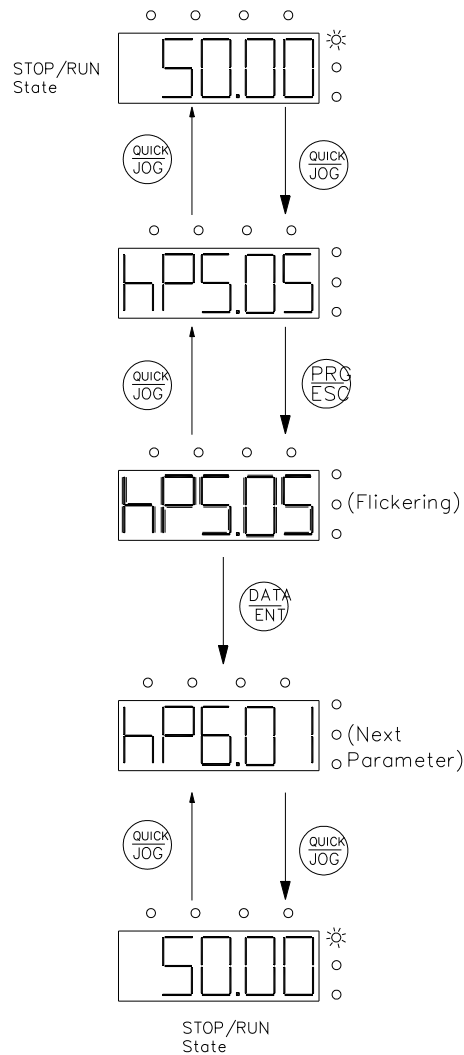

Figure 5-5 Example of Deleting Shortcut Parameter

Remarks: if press Button **PRG/ESC** under the first-stage shortcut menu, the display will be flickering, reminding whether or not to delete. Press Button **DATA/ENT** to confirm, and the display will stop flickering and jump to next QUICK parameter, ending the delete operation. If press Button **QUICK/JOE**, the display will stop flickering, canceling the delete operation. If the parameter to delete is the final one, “NULLP” will be displayed after it is deleted, indicating there is no any QUICK parameter.

5.2.3 Fault Reset

If the inverter has fault, it will prompt the related fault information. User can use Button **STOP/RST** or terminal function (P5 Group) to conduct fault reset. After fault reset, the inverter is at stand-by state. If user does not reset the inverter when it is at fault state, the inverter will be at operation protection state, and it is unable to run.

5.2.4 Parameter Copy

For details, please refer to the function description of LCD external keyboard

5.2.5 Motor Parameter Autotune

The procedure of motor parameter autotune is as follows:

At first, choose the keyboard command channel as the operation command channel (P0.01).

And then input following parameters according to the actual motor parameters:

P2.01: motor rated frequency;

P2.02: motor rated speed;

P2.03: motor rated voltage;

P2.04: motor rated current;

P2.05: motor rated power.

Important note: the motor should be uncoupled with its load; otherwise, the motor parameters obtained through autotune may be not correct. Set P0.17 to be 1, and for the detail process of motor parameter autotune, please refer to the description of Function Code P0.17. And then press Button **RUN** on the keyboard panel, the inverter will automatically calculate following parameter of the motor:

P2.06: motor stator resistance;

P2.07: motor rotor resistance;

P2.08: motor stator and rotor inductance;

P2.09: motor stator and rotor mutual inductance;

P2.10: motor no-load current; then motor autotune is finished.

5.2.6 Password Setting:

CHV series inverter provides user's cryptoguard function. When P7.00 is set to be nonzero, it is the user's password, and exiting function code edit mode will make the password become effective. If pressing Button **PRG/ESC** again to try to access the function code edit mode, "----" will be displayed, and the operator must input correct user's password, otherwise will be unable to access it.

If it is necessary to cancel the cryptoguard function, just set P7.00 to zero. User's cryptoguard has no protection to the parameters in shortcut menu.

5.3 Running State

5.3.1 Power-on Initialization

The system first conducts initialization during the inverter power-on, and LED displays "-CHV-". After the initialization is completed, the inverter is on stand-by status.

5.3.2 Stand-by

At stop or running state, parameters at multiple states can be displayed. Whether or not to display this parameter can be chosen through Function Code P7.06 (running parameter) and P7.07 (stop parameter) according to binary bits, which definitions can be seen in function-code-description of P7.06 and P7.07.

Under stop state, there are total sixteen stop state parameters which can be chosen whether to display or not. They respectively are: set frequency, bus voltage, on-off input status, open collector output status, PID setting, analog input AI1 voltage, analog input AI2 voltage, analog input AI3 voltage, analog input AI4 voltage, high speed pulse input 1 (HD11), high

speed pulse input 2 (HDI2), PLC and multi-speed stage number, actual count value, actual length and some reserved parameters. Whether or not to display these parameters can be decided by bit selection of Function Code P7.07 (converted into binary system), press Button  /SHIFT to switch the display of the chosen parameter.

5.3.3 Motor Parameter Autotune

For details, please refer to the description of Function Code P0.17

5.3.4 Operation

Under running state, there are five running parameters: operating frequency, set frequency, bus voltage, output voltage, output current, which are displayed permanently. Other sixteen display parameters: output power, output torque, PID setting, PID feedback, on-off input status, open collector output status, analog input AI1 voltage, analog input AI2 voltage, analog input AI3 voltage, analog input AI4 voltage, high speed pulse input 1 (HDI1), high speed pulse input 2 (HDI2), PLC and multi-speed stage number, actual count value, actual length and some reserved parameters, whether or not to display can be decided by the bit selection of Function Code P7.07 (converted into binary system), press Button  /SHIFT to switch the display of the chosen parameter.

5.3.5 Fault

CHV series inverter provides a variety of fault information, which, for details, can be referred to CHV series inverter faults and their countermeasures.

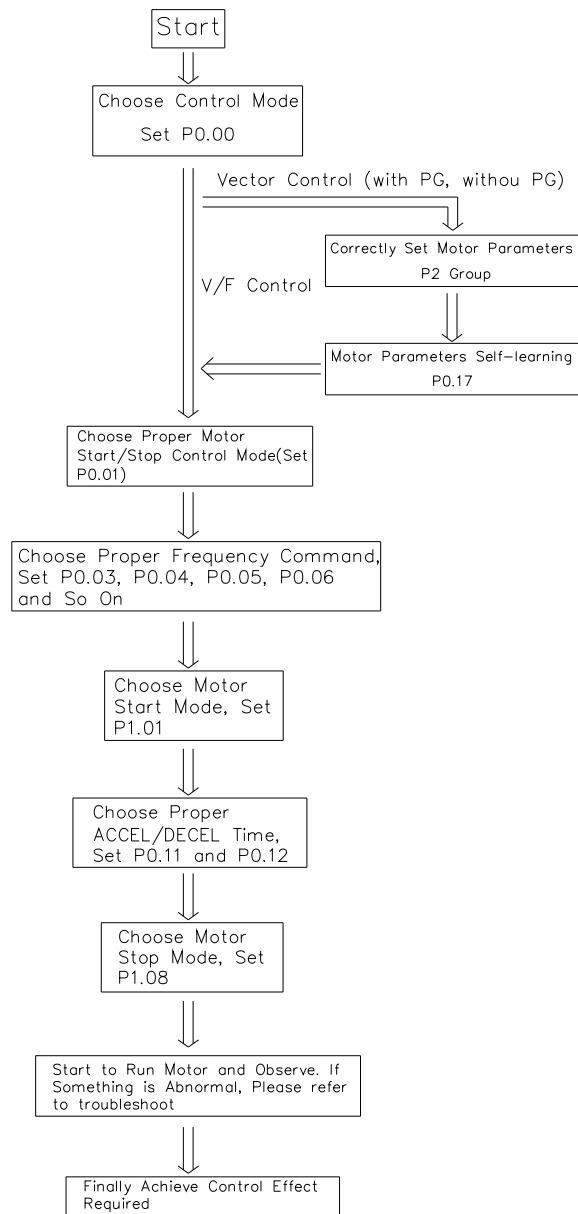

Figure 5-6 Quick Testing Process Diagram

6. Detail Function Description

Basic Function Group

Function Code	Name	Description	setting range	Default Value
P0.00	Speed Control Mode	0: V/F Control	0	0

Selection of Speed Control Mode

0: V/F Control Mode

V/F control mode is suitable for the application which does not require high control accuracy, and also suitable for cases with one inverter driving multiple motors.

Function Code	Name	Description	setting range	Default Value
P0.01	Operation command Path	0: Keyboard Command Path (LED extinct) 1: Terminal Command Path (LED blinking) 2: Communication Command Path (LED light up)	0~2	0

Path Selection for the inverter Control Command

The inverter control commands include: start, stop, forward, reverse, jogging, failure reset and so on.

0: Keyboard Command Path (LOCAL/REMOT light extinct);

The buttons **RUN** and **STOP/RST** on the keyboard are for operation control. Multifunction key **QUICK/JOG**, if set up as FWD/REV switching function (P7.03 is set up as 1), can change the rotating direction; When at operation, pushing **RUN** and **STOP/RST** in same time will make the inverter stop freely.

1: Terminal Command Path (LOCAL/REMOT blinking)

Multifunction input terminals of forward, reverse, forward jogging, reverse jogging and so on, perform the operation command control.

2: Communication Command Path (LOCAL/REMOT light up)

Operation command control is performed through communication pattern by upper position machine. If it is chosen, it is a must to use the serial communication interface card (Optional part) from our company.

Function Code	Name	Description	setting range	Default Value
P0.02	Keyboard and terminal UP/DOWN setting	0: Valid, and the inverter memorizes when power down 1: Valid, and the inverter does not memorize when power down 2: Invalid	0~2	0

CHV series inverter can set up the frequency though **▲** and **▼** buttons on the keyboard and terminal UP/DOWN (Frequency setting increase /Frequency setting decrease), and as it has the highest purview, it can combine with any other frequency setting path to mainly accomplishes the fine adjustment of inverter output frequency during control system commissioning.

0: 0: Valid, and the inverter memorizes when power down. Able to set up frequency command, and memorize this set frequency when the inverter is power down. When the power is back, automatically combine it with current frequency setting.

1: Valid, and the inverter does not memorize when power is down. Able to set up frequency, but when the inverter power is down, this frequency setting is not memorized.

2: Invalid. The frequency set through keyboard and terminal UP/DOWN is automatically cleared, and the settings through keyboard and terminal UP/DOWN are invalid.

Note: After the user restores the default values of inverter function parameters, the frequency value, set through keyboard and terminal UP/DOWN, is automatically cleared.

Function Code	Name	Description	setting range	Default Value
P0.03	Frequency command A selection	0: Keyboard Setting 1: Analog AI1 setting 2: Analog AI3 setting 3: High speed pulse setting 4: Simple PLC program setting 5: Multi-speed operation setting 6: PID control setting 7: Remote communication setting	0~7	0

Selection of inverter frequency command A input channels. There are 8 main frequency setting channels:

0: Keyboard setting

Accomplish keyboard frequency setting by means of modifying the value of function code P0.10 “Keyboard frequency setting”.

1: Analog AI1 setting

2: Analog AI3 setting

This means that the frequency is set up through analog input terminals. CHV series inverter standard configuration provides 2 analog input terminal paths, and besides, optional multi-function I/O extension card can provide 2 analog input terminals (AI3 and AI4). Terminal AI1, AI3 and AI4 are 0-10V voltage input mode, while AI2 can be 0-10V voltage input and also can be 0 (4)-20mA amperage input. Voltage input and current input can be switched by Jumper J18.

The 100.0% setting of analog input is corresponding to the maximum frequency (Function Code P0.07), and -100.0% is corresponding to maximum reverse frequency (Function Code P0.07).

3: High speed pulse setting (HDI1)

This means that inverter frequency setting is set through terminal high speed pulse input. CHV series inverter standard configuration provides 1 path of high speed pulse input (HDI1), and besides, optional multi-function I/O extension card can provide another one path of high speed pulse input (HDI2).

Pulse setting signal Rating : pulse voltage range 15-30V, and pulse frequency range 0.0-50.0KHz.

The 100.0% setting of pulse input is corresponding to the maximum frequency (Function Code P0.07), and also -100.0% is corresponding to the maximum reverse frequency (Function Code P0.07).

Note: pulse setting can only be set by multifunction input terminal HDI1 or HDI2. Moreover, P5.00 setting of HDI1 or HDI2 should be set as high speed pulse input, and P5.35 should be set as “Setting Input”.

4: Simple PLC program setting

If this frequency setting mode is chosen, the inverter is operated by simple PLC program. It is needed to set up the parameters of PA Group “Simple PLC and multi-speed control group” to determine given percentage and given frequency, the coincidence relation between plus minus and rotating direction, and selection of acceleration and deceleration time as well. For details, please refer to description of PA Group functions.

5: Multi-speed operation setting

The inverter is operated in the mode of multi-speed once this frequency setting mode is chosen. It is needed to set up the parameters of P5 Group and PA Group “Simple PLC and multistage speed control group” to determine the coincidence relation between given percentage and given frequency.

6: PID control setting

Selection of this parameter means that the operation mode of inverter is process PID control mode. In this case, it is required to set up P9 Group “PID control group”. The operation frequency of inverter is the frequency value after the PID action. Please refer to the description of P9 Group “PID functions” for the definition of PID giving source, assigned value, feedback source and so on.

7: Remote communication setting

The frequency command is given in the communication mode by upper position machine. For details, please refer to “CHV Series inverter ModBus Communication Agreement”.

Function Code	Name	Description	setting range	Default Value
P0.04	Frequency Command B Selection	0: Analog AI2 setting 1: Analog AI4 setting 2: High speed pulse setting (HDI2)	0~2	0
P0.05	Frequency Command B Reference Object Selection	0: Maximum frequency output 1: A frequency command	0~1	0

When frequency command B serves as the independent frequency giving channel (i.e. frequency source is selected as switching from A to B), its usage is the same as that of frequency command A.

When Frequency Command B acts as overlap setting (i.e. frequency source is chosen as A+B), it has particular features:

1. Input Setting (AI2, AI4): 100% set by Input Setting (AI2 and AI4) is corresponding to the reference object chosen by P0.05. If it is required to adjust based on Frequency Command A, the reference object should be set as Frequency Command A, and thus 100.0% that Frequency Command B refers to is the setting value of Frequency Command A.

2. When frequency source is high speed pulse input (HDI2) setting, it is similar to analog setting.

Function Code	Name	Description	setting range	Default Value
P0.06	Combined mode of setting source	0: A 1: B 2: A+B 3: Max (A, B)	0~3	0

The frequency setting channel is selected through this parameter. The frequency setting is achieved by combining Frequency Command A and Frequency Command B.

(0, 1, 2) combining modes can be switched by terminal function (P5 Group).

Selecting "A+B" can realize the function of frequency overlap setting. CHV series inverter can realize mutually switching between frequency setting modes.

Max (A, B) : means that if Frequency Command A is bigger than Frequency Command B, Frequency Command A is set as the set frequency, and vice versa, Frequency Command B is set as the set frequency.

Function Code	Name	Description	setting range	Default Value
P0.07	Maximum Output Frequency	10.00~ 600.00Hz	10.00~ 600.00	50.00Hz

It is used to set up the maximum output frequency of inverter. Please note that, it is the basis of frequency setting and acceleration/deceleration speed.

Function Code	Name	Description	setting range	Default Value
P0.08	Upper limit frequency	P0.09~ P0.07 (maximum frequency)	P0.09~ P0.07	50.00Hz

It is the upper limit of inverter output frequency, which should be less than or equal to the maximum output frequency.

Function Code	Name	Description	setting range	Default Value
P0.09	Lower limit frequency	0.00 Hz ~ P0.08 (Upper limit frequency)	0.00~ P0.08	0.00Hz

The lower limit of inverter output frequency.

It can be chosen through function code P1.14, and acts when the set frequency is lower than the lower frequency limit: operate at the lower limit frequency, stop or be dormant.

Therein, Maximum output frequency \geq upper limit frequency \geq lower limit frequency.

Function Code	Name	Description	setting range	Default Value
P0.10	Keyboard frequency setting	0.00 Hz ~ P0.08 (upper limit frequency)	0.00~P0.08	50.00Hz

When Frequency Command A is chosen as "keyboard Setting", this function code value is the initial set value of inverter frequency.

Function Code	Name	Description	setting range	Default Value
P0.11	Acceleration time 0	0.0~3600.0s	0.0~3600.0	20.0s
P0.12	Deceleration time 0	0.0~3600.0s	0.0~3600.0	20.0s

Acceleration time means the time t_1 required for inverter to accelerate to the maximum output frequency (P0.07) from 0Hz.

Deceleration time is the time t_2 required for inverter to decelerate to 0Hz from the maximum output frequency (P0.07).

It is indicated by following figure

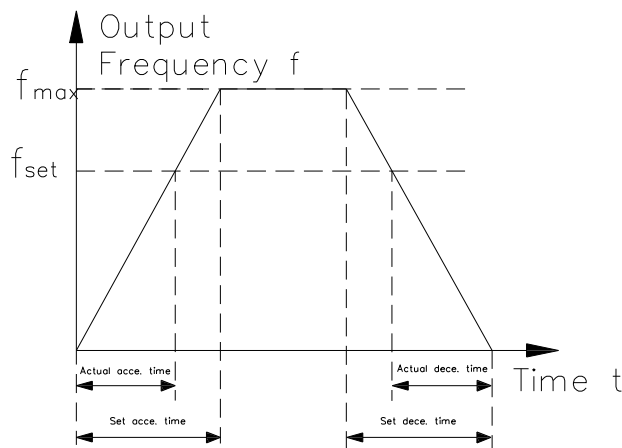

Figure 6-1 Acceleration and Deceleration time diagram

When the set frequency is equal to the maximum frequency, the actual Acceleration/Deceleration time are equal to the set Acceleration/Deceleration time.

When the set frequency is less than the maximum frequency, the actual Acceleration/Deceleration time are less than the set Acceleration/Deceleration time.

Actual Acceleration /Deceleration time = set Acceleration/Deceleration time \times (set frequency/max. frequency)

CHV series inverter has 4 groups of Acceleration/Deceleration time.

1st group: P0.11, P0.12;

2nd group: P8.00, P8.01;

3rd group: P8.02, P8.03;

4th group: P8.04, P8.05.

The Acceleration /Deceleration time can be chosen through multifunction digital input terminal (P5 Group).

Function Code	Name	Description	setting range	Default Value
P0.13	Operation direction selection	0: Operating at default direction 1: Operating at reverse direction 2: Forbid inverse operating	0~2	0

0: Operating at default direction. When the inverter is power connected, it operates at the actual direction.

1: Operating at reverse direction. By means of changing the function code, the motor rotating direction can be changed without changing any other parameters, which is equivalent

to change the motor rotating direction by exchanging any two of motor cables (U, V, W).

Note: After the parameters are initialized, the motor operating direction can be restored to be its original state. Be caution to use it in the case that changing motor rotating direction is forbidden after the system commissioning is completed.

2: Forbid inverse operating. Forbidding inverter inverse operation is suitable to specific application that inverse operating is forbidden.

Function Code	Name	Description	setting range	Default Value
P0.14	Carrier Frequency Setting	1.0~16.0kHz	1.0~16.0	Set by model

This function is mainly used to improve the problem of motor operating noise and inverter interference to external and so on.

The advantages of using high carrier frequency: relatively ideal current wave shape, less harmonic current wave and low motor noise;

The disadvantages of using high carrier frequency: increased switch loss and inverter temperature rises, affecting inverter output capacity so that it should be operated at derating under high carrier frequency conditions; in the mean time, inverter leakage current and its electromagnetic interference to external are increased.

The situations of using low carrier frequency is on the contrary. Too low carrier frequency can cause operation unstable, torque reduced and even oscillation at low frequency.

When inverter is factory released, its carrier frequency has been set properly. Generally the user does not need to modify this parameter.

When the user uses a frequency higher than the default carrier frequency, derating is needed.

Function Code	Name	Description	setting range	Default Value
P0.15	PWM mode option	0: Fixed PWM mode 1: Random PWM mode	0~1	0

Two PWM mode options, fixed PWM mode and random PWM mode, are provided.

0: The frequency of noise produced by fixed PWM motor is fixed.

1: Random PWM mode can effectively restrain motor noise, but may cause the harmonic wave increasing.

Function Code	Name	Description	setting range	Default Value
P0.16	Carrier frequency adjustment	0: Carrier frequency does not adjust based on temperature 1: Carrier frequency adjusts based on temperature	0~1	0

0: Carrier frequency does not adjust based on temperature, so the carrier frequency is fixed (the set value of P0.14)

1: Carrier frequency adjusts based on temperature: when temperature-rise is increasing, the inverter automatically decreases the carrier frequency; when temperature-rise is decreasing, the carrier frequency is increased. The application of this function can effectively prevent the frequent overheat alarm.

Function Code	Name	Description	setting range	Default Value
P0.17	Motor parameters autotune	0: no operation 1: Parameters autotune	0~1	0

0: NO operation, i.e. forbidding autotune.

1: Parameters autotune

Prior to parameters autotune, the motor must be disconnected with its load, ensuring the motor at no-load condition, and confirming the motor is at static state.

Prior to parameters autotune, it is a must to correctly input the motor nameplate parameters (P2.01 – P2.05), otherwise what is self learned about motor parameters may be not correct.

Prior to parameters autotune, the Acceleration and Deceleration time (P0.11 and P0.12) should be set properly based on the motor inertia, otherwise over current fault may happen during motor parameters autotune.

When the autotune of motor parameters is started by setting P0.17 as 1 and then pushing the button **DATA/ENT**, LED displays “-TUN-” and flickering, then push the button **RUN** to begin the procedure of the motor parameters autotune. At this time, “TUN-0” is displayed. After the motor is started, “TUN-1” is shown and “RUN/TUNE” light is flickering. When the autotune of parameters is finished, “-END-” is displayed, and finally back to the stop state interface. When “-TUN-” is blinking, the process of parameters autotune can exit by pushing the button **PRG/ESC**.

During the process of parameters autotune, it can be stopped by pressing the button **STOP/RST**. Please note, the start and stop of the parameters autotune can only be done through keypad. Once the parameter autotune is finished, this function code automatically restores to 0.

Function Code	Name	Description	setting range	Default Value
P0.18	Function parameters restoration	0: NO operation 1: Restore default value 2: Delete failure records	0~2	0

1: The inverter restores all parameters to their default value.

2: The inverter deletes recent failure records.

After the chosen function operation is completed, this function code is automatically restored to 0.

P1 Group Start and Stop Control Group

Function Code	Name	Description	setting range	Default Value
P1.00	Start Mode	0: Direct start 1: DC braking first and then start 2: Rotating speed tracking and then start	0~2	0

0: Direct start: start from the starting frequency.

1: DC braking first and then start: First perform DC braking (pay attention to set up parameters P1.03 and P1.04), and then start and run the motor at the start frequency. It is suitable for small inertia loading which can cause reverse rotation at starting.

2: Rotating speed tracking and then start: the inverter first calculates motor rotating speed and direction, and then start running to its set frequency from current speed, performing a smooth no-shock start to moving motor. This mode is applicable to momentary power-down start when the inertia loading is big.

Function Code	Name	Description	setting range	Default Value
P1.01	Starting frequency of direct start	0.00~10.00Hz	0.00~10.00	0.00Hz
P1.02	Hold time of starting frequency	0.0~50.0s	0.0~50.0	0.0s

Setting proper starting frequency can increase the starting torque. Within the hold time of the starting frequency (P1.02), the inverter output frequency is the starting frequency, and then, from the starting frequency, running to the target frequency. If the target frequency (frequency command) is less than the starting frequency, inverter does not operate and is at stand-by state. The starting frequency value is not restricted by the lower limit frequency.

During FWD/REV switching, the starting frequency is inactive.

Function Code	Name	Description	setting range	Default Value
P1.03	Braking current before starting	0.0~150.0%	0.0~150.0	0.0%
P1.04	Braking time before starting	0.0~50.0s	0.0~50.0	0.0s

When it is being started, the inverter first performs DC braking according to the set prior-to-starting DC braking current, and after the set prior-to-starting DC braking time is passed then begins to perform acceleration. If the set DC braking time is 0, DC braking is invalid.

The bigger the DC braking current, the greater the braking force. The prior-to-starting DC braking current is the percentage of the rated inverter current.

Function Code	Name	Description	setting range	Default Value
P1.05	Acceleration and Deceleration mode options	0: Linear mode 1: S curve mode	0~1	0

This function is to choose the frequency changing modes during start and stop operation.

0: Linear mode

The output frequency is linearly increasing or decreasing. The Acceleration and Deceleration time varies based on the set Acceleration and Deceleration time. CHV series inverter provides 4 kinds of specific Acceleration and Deceleration time, which can be selected

through the multifunction digital input terminals (P5 Group).

1: S curve mode

The output frequency is increasing or decreasing by following S curve. Normally S curve mode is used in applications which require relatively smooth and gentle start and stop, such as elevators, belt conveyor. For its parameter definitions, refer to P1.06 and P1.07.

Function Code	Name	Description	setting range	Default Value
P1.06	S curve beginning stage scale	0.0~40.0% (Acce, Dece time)	0.0~40.0	30.0%
P1.07	S curve ending stage scale	0.0~40.0% (Acce, Dece time)	0.0~40.0	30.0%

The t_1 in following figure is the time defined by P1.06, within which the output frequency is changed in a gradually increased slope. The t_2 is the time defined by P1.07. Within the period between t_1 and t_2 , the frequency changing slope is constant. The curvature of S curve is codetermined by the Acceleration range, the Acceleration/Deceleration time, beginning stage time and the ending stage time.

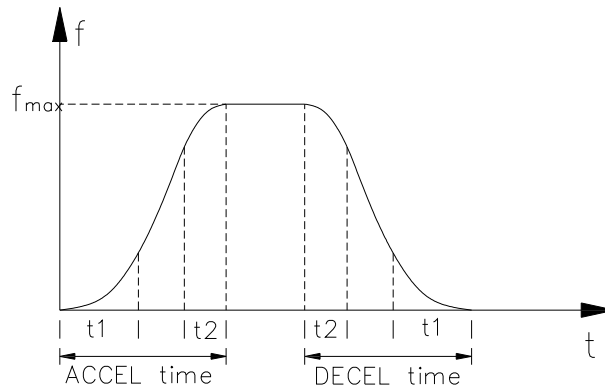

Figure 6-2 S curve Acceleration/Deceleration diagram

Function Code	Name	Description	setting range	Default Value
P1.08	Stop Mode Option	0: Deceleration Stop 1: Free-run Stop	0~1	0

0: Deceleration stop

After the stop command is enabled, the inverter decreases the output frequency according to the Deceleration mode and the defined Acceleration /Deceleration time, and the motor is stopped when the frequency is 0.

1: Free-run stop

Once the stop command is valid, the inverter immediately ends the output. The loading is freely stopped by its mechanical inertia.

Function Code	Name	Description	setting range	Default Value
P1.09	Beginning Frequency of DC brake when stopping	0.00~10.00Hz	0.00~10.00	0.00Hz
P1.10	Waiting time of DC brake when stopping	0.0~50.0s	0.0~50.0	0.0s

P1.11	DC brake current when stopping	0.0~150.0%	0.0~150.0	0.0%
P1.12	DC brake time when stopping	0.0~50.0s	0.0~50.0	0.0s

Beginning frequency of DC brake when stopping: During the Deceleration stop, when this frequency is reached, the DC brake is started.

Waiting time of DC brake when stopping: Prior to the DC brake, the inverter blocks the output, and after this delay time, the DC braking is started. It is used to prevent over-current fault caused by DC braking at high speed.

DC brake current when stopping: indicates the applied DC brake energy. The bigger the current, the stronger the DC brake energy should be.

DC brake time when stopping: the durative time that the DC brake energy is applied. If the time is 0, DC brake is invalid, and the inverter stops the motor based on the set Deceleration time.

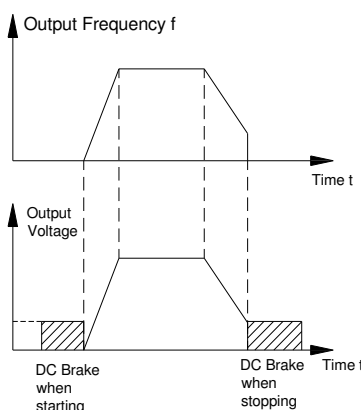

Figure 6-3 DC Brake Diagram

Function Code	Name	Description	setting range	Default Value
P1.13	Dead time	0.0~3600.0s	0.0~3600.0	0.0s

It is to set the transient time during which the output frequency is 0 in the FOR/REV transient process of inverter.

It is shown as following figure:

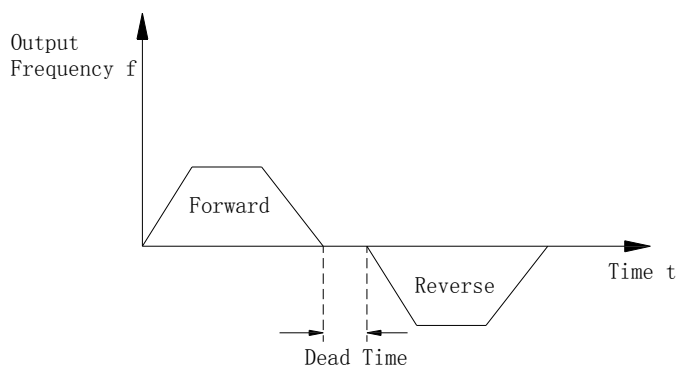

Figure 6-4 FOR/REV Dead Time Diagram

Function Code	Name	Description	setting range	Default Value
P1.14	Running mode if operating Frequency is less than lower limit frequency (Valid if the lower limit is more than 0)	0: Run at the lower frequency limit 1: Stop 2: Stand-by state	0~2	0

This function code is to determine the inverter operating state when the set frequency is less than the lower limit frequency.

0: Run at the lower limit frequency: means that the inverter runs at the lower limit frequency when the operating frequency is less than the lower limit frequency.

1: Stop. In order to prevent motor operating at low speed for a long period of time, can use this function to stop.

2: stand-by state. Inverter stops when the set frequency is less than the lower limit frequency. When the set frequency is once again higher than or equal to the lower frequency limit, the inverter automatically starts to run.

Note: For PID control mode, the stand-by state function is invalid.

Function Code	Name	Description	setting range	Default Value
P1.15	Power-back restart option	0: NO restart 1: Permit restart	0~1	0
P1.16	Restart waiting time	0.0~3600.0s (Valid if P1.15 is 1)	0.0~3600.0	0.0s

0: NO restart. Indicate that after the power is down, the inverter does not automatically restart if the power is back, until an operating command is input.

1: Permit restart. It indicates that if keypad control or remote communication control is applied, when the power is back on, no matter whether operation command exists or not, the inverter can automatically restart after the restart delay time (P1.16) is passed; If under terminal control mode, only when the terminal control start is valid, the inverter can automatically restart after the restart delay time (P1.16) is passed. If the power is down at stand-by, the permit restart function is invalid.

Important: the user must chose the permit restart function with caution, otherwise, it may cause serious consequences.

P2 Group Motor parameters group

Function Code	Name	Description	setting range	Default Value
P2.00	Model Selection	0: G Model 1: P Model	0~1	0

0: applicable for constant torque load of designated nominal parameter.

1: suitable for variable torque load (such as blower and pump load) of designated nominal parameter.

Note: This parameter can only view the model of this equipment, and can not be changed.

Function Code	Name	Description	setting range	Default Value
P2.01	Motor rated frequency	0.01Hz~P0.07	0.01~P0.07	50.00Hz
P2.02	Motor rated speed	0~36000rpm	0~36000	1460rpm
P2.03	Motor rated voltage	0~440V	0~440	380V
P2.04	Motor rated current	0.1~1000.0A	0.1~1000.0	Set by model
P2.05	Motor rated power	0.4~900.0kW	0.4~900.0	Set by model

Note: please set these codes according to motor nameplate parameters.

CHV series inverter provides parameter autotune function. Accurate parameter autotune comes from correct setting of motor nameplate parameters.

In order to ensure the control performances, please do the motor setting based on the inverter standard adaptive motor. If the motor rated power has a too big difference to the standard adaptive motor, the inveter control performances will be deteriorated distinctly.

Note: resetting of motor rated power (P2.05) can initialize motor parameter P2.06-P2.10.

Function Code	Name	Description	setting range	Default Value
P2.06	Motor stator resistance	0.001~ 65.535Ω	0.001~ 65.535	Set by model
P2.07	Motor rotor resistance	0.001~ 65.535Ω	0.001~ 65.535	Set by model
P2.08	Motor stator and rotor inductance	0.1~ 6553.5mH	0.1~ 6553.5	Set by model
P2.09	Mutual inductance of motor stator and rotor	0.1~ 6553.5mH	0.1~ 6553.5	Set by model
P2.10	Motor no-load current	0.01~ 655.35A	0.01~ 655.35	Set by model

After the motor autotune is normally ended, P2.06-P2.10 setting values are automatically replaced. These parameters are the basis of high performance control and have direct effect on the control performance.

Important: users DO NOT change this group parameters at will.

P3 Reserved

P4 V/F control parameter

Function Code	Name	Description	setting range	Default Value
P4.00	V/F curve setting	0: Linear V/F curve 1: Multipoint V/F curve 2: 1.3 exponential decreasing torque V/F curve 3: 1.7 exponential decreasing torque V/F curve 4: 2.0 exponential decreasing torque V/F curve	0~4	0

0: Linear V/F curve. It is applicable to regular constant torque load.

1: Multipoint V/F curve. V/F curve can be defined through setting (P4.03-P4.08).

2-4: multi- exponential V/F curve. It is applicable to variable torque load, such as blower, pump and so on. Each exponential curve is shown in following figure:

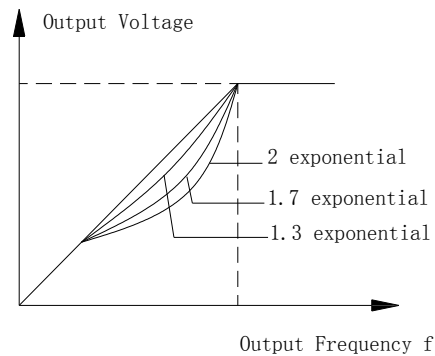

Figure 6-6 V/F curve diagram

Function Code	Name	Description	setting range	Default Value
P4.01	Torque Boost	0.0%: (auto) 0.1%~30.0%	0.0~30.0	1.0%
P4.02	Torque Booth cut-off point	0.0%~50.0% (relative to motor rated frequency)	0.0~50.0	20.0%

Torque Boost is mainly applied to less than cut-off frequency (P4.02). The V/F curve after boost is shown in following figure. Torque booth can improve the low frequency torque performance of V/F control.

Based on the load, a torque should be chosen properly. For heavy load, increase the torque boost, but the torque boost should not be set too big, which will result in the motor operating at overexcitation and that it could be overheated, and also the inverter output current is big, reducing efficiency.

When the torque boost is set as 0.0%, the inverter is at automatic torque boost.

Torque boost cut-off frequency: below this frequency, torque boost is valid, and above this frequency setting, torque boost is invalid.

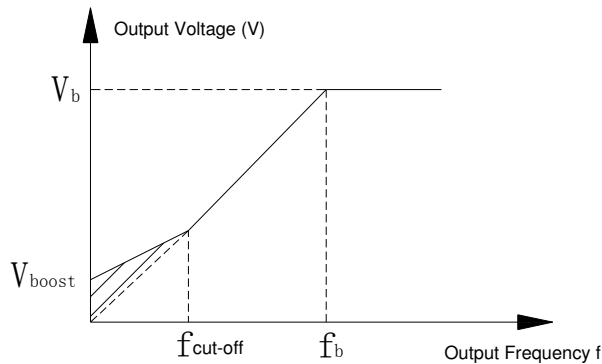

Figure 6-7 Manual torque boost diagram

Function Code	Name	Description	setting range	Default Value
P4.03	V/F frequency point 1	0.00Hz~ P4.05	0.00~P4.05	5.00Hz
P4.04	V/F voltage point 1	0.0%~100.0%	0.0~100.0	10.0%
P4.05	V/F frequency point 2	P4.03~ P4.07	P4.03~ P4.07	30.00Hz
P4.06	V/F voltage point 2	0.0%~100.0%	0.0~100.0	60.0%
P4.07	V/F frequency point 3	P4.05~ P2.01	P4.05~ P2.01	50.00Hz
P4.08	V/F voltage point 3	0.0%~100.0%	0.0~100.0	100.0%

The six P4.03-P4.08 parameters define the multi-section V/F curve.

V/F curve setting values are generally set according to the motor's loading performance.

Note: $V_1 < V_2 < V_3$, and $f_1 < f_2 < f_3$. A too high low-frequency voltage setting may cause motor overheated and even burn, and the inverter might occur over-current stall or over-current protection.

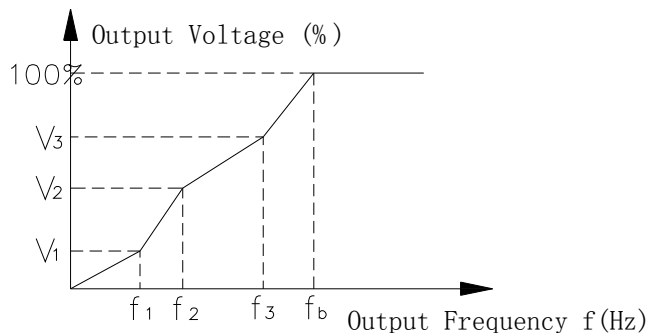

Figure 6-8 V/F curve setting diagram

Function Code	Name	Description	setting range	Default Value
P4.09	V/F slip compensation range	0.00~10.00Hz	0.00~10.00	0.0Hz

Setting this parameter can compensate the motor speed change produced because of undertaking loading while on V/F control, to increase the rigidity of motor mechanical

performance. This value should be set as the motor rated slip frequency, which can be calculated as below:

$$P4.09 = fb - n * p / 60$$

Where fb is the motor rated frequency, corresponding to P2.01, n is the motor rated speed, corresponding to P2.02, and p is number of pole pairs of motor.

Function Code	Name	Description	setting range	Default Value
P4.10	AVR function selection	0: Invalid 1: Always valid 2: Only valid when deceleration	0~2	1

AVR function is the auto-voltage-regulation function of output voltage. When AVR function is invalid, the output voltage changes as the input voltage (or DC bus voltage) changes; when AVR function is valid, the output voltage does not change as the input voltage (or DC bus voltage) does, and it basically keep constant within the output capacity range.

Function Code	Name	Description	setting range	Default Value
P4.11	Energy-saving operation selection	0: No action 1: Auto-energy-saving operation	0~1	0

During the motor operation with no load or light load, by means of detecting the loading current, appropriately regulate output voltage to save energy automatically.

Important: this function is especially effective for loadings like blower and pump.

Function Code	Name	Description	setting range	Default Value
P4.12	Terminal function detection when power on	0: Terminal operation command invalid when power on 1: Terminal operation command valid when power on	0~1	0

When the operation command path is terminal control, during the inverter powers on, the system inspects the status of operation terminal.

0: Terminal operation command invalid when power on. During power on, even if the operation command terminal is inspected valid, the inverter will not run, the system stays in operation-protection state, till this operation command terminal is cancelled, and then, active this terminal, the inverter will run.

1: Terminal operation command valid when power on. During power on, if the operation command terminal is inspected valid, the system will start the inverter after initialization.

Important: User should select this function carefully, or it could cause serious result.

P5 Group Input Terminal Group

CHV series inverter standard unit has 6 multi-function digital input terminals (in which HDI1 can be used as the high speed pulse input terminal) and 2 analogue input terminals. If the system needs more input and output terminals, a multifunction I/O extension card should be installed.

Function Code	Name	Description	setting range	Default Value
P5.00	HDI input type selection	0: HDI1 and HDI2 both are high speed pulse input 1: HDI1 is on-off input and HDI2 is high speed pulse input 2: HDI2 is on-off input and HDI1 is high speed pulse input 3: HDI1 and HDI2 are both on-off input	0~3	0

HDI input type selection function code determines HDI1 and HDI2 are high speed pulse input or on-off input.

Function Code	Name	Description	setting range	Default Value
P5.01	Terminal function input selection	0: physical on-off input 1: communication virtual terminal input	0~1	0

This function code determines the terminal input channel.

0: physical on-off input, i.e. the on-off signal is input through external terminals.

1: communication virtual terminal input, i.e. the on-off signal is set up through upper position machine via communication pattern.

Function Code	Name	Description	setting range	Default Value
P5.02	S1 Terminal Function Selection	Programmable multifunction terminal	0~39	1
P5.03	S2 Terminal Function Selection	Programmable multifunction terminal	0~39	4
P5.04	S3 Terminal Function Selection	Programmable multifunction terminal	0~39	7
P5.05	S4 Terminal Function Selection	Programmable multifunction terminal	0~39	0
P5.06	S5 Terminal Function Selection	Programmable multifunction terminal	0~39	0
P5.07	HDI1 terminal on-off input function selection	Programmable multifunction terminal	0~39	0
P5.08	HDI2 terminal on-off input function selection	Programmable multifunction terminal	0~39	0
P5.09	S6 Terminal Function Selection	Programmable multifunction terminal	0~39	0
P5.10	S7 Terminal Function Selection	Programmable multifunction terminal	0~39	0
P5.11	S8 Terminal Function Selection	Programmable multifunction terminal	0~39	0

These parameters are used to set up the corresponding functions of digital multifunction input terminals.

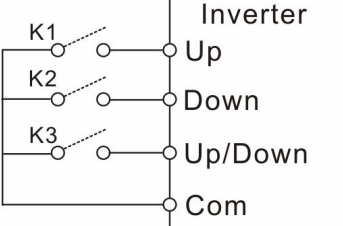
setting value	Function	Description
0	Function	Even if there is a signal input, the inverter does not run. Terminals which are not used can be set to be no function in order to prevent malfunction
1	(FWD) Forward	The inverter's forward or reverse running can be control by external terminals.
2	(REV) Reverse	
3	three-wire operation control	By means of this terminal the inverter's operation mode can be defined to be three-wire control mode. For details, please refer to the function code description of P5.13 three-wire control mode.
4	Forward Jogging	At Jogging operation, the frequency and Jogging Acceleration or Deceleration time can be found in detail descriptions of P8.06,P8.07 and P8.08 function codes
5	Reverse Jogging	
6	Free-run stop	The inverter turns off output, and the motor stop process is not controlled by the inverter. It is often applied when the inertia loading is big and there is no requirement on how long to stop. This mode has the same definition as P1.08 does
7	Failure reset	This is external failure reset. It has the same function as STOP/RST button on the keyboard. Using this function can perform long-distance failure reset.
8	Operation pause	The inverter decelerates to stop, but all operation parameters, such as PLC parameters, traverse frequency parameters and PID parameters, are in memory state. After this signal disappears, the inverter restores the operation to the status before pause.
9	External fault input	When external fault signal is input into inverter, the inverter reports it and stops.
10	Frequency up setting	 <p>When the frequency is set by external terminal, modify the frequency up and down command. When the frequency source is set as digital</p>
11	(DOWN) Frequency down setting	

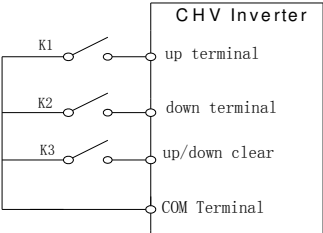
setting value	Function	Description																				
12	Frequency up/down setting clear	<p>setting, the set frequency can be regulated up and down.</p>  <p>Using terminal can clear UP/DOWN set frequency to restore the frequency setting to be given by frequency command channel.</p>																				
13	Switching between A setting and B setting	<p>This terminal function can perform command channel switching. If the current frequency giving channel is A, using Terminal #13 function can switch to B, and using Terminal #15 function can switch to A+B, but Terminal #14 is invalid. Other logics are similar.</p>																				
14	Switching between A setting and A+B setting																					
15	Switching between B setting and A+B setting																					
16	Multi-speed terminal 1	<p>16 stages speed can be set up via these four terminals digital state combination.</p> <p>Note: multi-speed 1 is the low position, and multi-speed 4 is the high position</p>																				
17	Multi-speed terminal 2																					
18	Multi-speed terminal 3																					
19	Multi-speed terminal 4																					
20	Multi-speed pause	This terminal function can shield the function of multi-speed terminals and keep the set value as the current state.																				
21	Acceleration/Deceleration time selection terminal 1	<p>4 kinds of Acceleration/Deceleration time can be chosen via these two terminals digital state combination.</p> <table border="1" data-bbox="566 1601 1348 1915"> <thead> <tr> <th>Terminal 2</th> <th>Terminal 1</th> <th>Acceleration or Deceleration time select</th> <th>Corresponding Parameter</th> </tr> </thead> <tbody> <tr> <td>OFF</td> <td>OFF</td> <td>Acceleration Time 0</td> <td>P0.11、 P0.12</td> </tr> <tr> <td>OFF</td> <td>ON</td> <td>Acceleration Time 1</td> <td>P8.00、 P8.01</td> </tr> <tr> <td>ON</td> <td>OFF</td> <td>Acceleration Time 2</td> <td>P8.02、 P8.03</td> </tr> <tr> <td>ON</td> <td>ON</td> <td>Acceleration Time 3</td> <td>P8.04、 P8.05</td> </tr> </tbody> </table>	Terminal 2	Terminal 1	Acceleration or Deceleration time select	Corresponding Parameter	OFF	OFF	Acceleration Time 0	P0.11、 P0.12	OFF	ON	Acceleration Time 1	P8.00、 P8.01	ON	OFF	Acceleration Time 2	P8.02、 P8.03	ON	ON	Acceleration Time 3	P8.04、 P8.05
Terminal 2	Terminal 1		Acceleration or Deceleration time select	Corresponding Parameter																		
OFF	OFF		Acceleration Time 0	P0.11、 P0.12																		
OFF	ON		Acceleration Time 1	P8.00、 P8.01																		
ON	OFF	Acceleration Time 2	P8.02、 P8.03																			
ON	ON	Acceleration Time 3	P8.04、 P8.05																			
22	Acceleration/Deceleration time selection terminal 2																					
23	Simple PLC reset	Restart PLC operation.																				
24	Simple PLC	PLC procedure is suspended during its executive process, and																				

setting value	Function	Description
	pause	operates at the current speed all the time. After this function is cancelled, simple PLC continues its procedure.
25	PID control pause	PID is temporarily out of work, and the inverter keeps its current frequency output.
26	Traverse pause	The inverter pauses at its current output frequency. After this function is cancelled, continue to start its traverse operation at its current frequency.
27	Traverse reset	The inverter is back to its center frequency output.
28	Counter reset	Counter status clear.
29	Length reset	Length clear.
30	Acce/Dece forbid	Ensure the inverter is not interfered by external signals (excluding stop command), maintaining its current output frequency.
31	Torque control forbid	Forbid the inverter operating in torque control mode.
32~47	Reserved	Reserved

Function Code	Name	Description	setting range	Default Value
P5.12	On-off signal filtering times	1~10	1~10	5

It sets up S1-S8, HDI1 and HDI2 terminals sample filtering time. In big interference situation, this parameter should be increased in order to prevent maloperation.

Function Code	Name	Description	setting range	Default Value
P5.13	Terminal control mode	0: two-wire type control, integrate Enable with direction 1: two-wire type control, separate Enable from direction 2: three-wire type control, integrate Enable with direction 3: three-wire type control, separate Enable from direction	0~3	0

This parameter defines four different control modes which controls the inverter operation through external terminals.

0: Two-wire type control, integrate Enable with direction. This mode is the most often used two-wire control mode. The motor forward and reverse operations are determined by the defined FWD and REV terminal command.

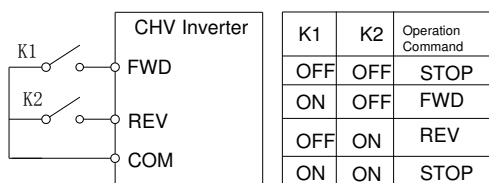

Figure 6-9 Two-wire operation mode 1

1: Two-wire control, separate Enable from direction. When this mode is used, the defined FWD is enable terminal. The direction is determined by the defined REV state.

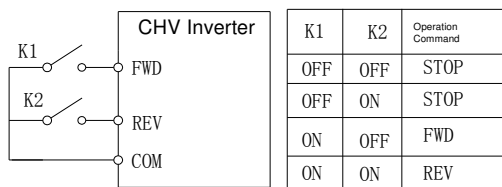

Figure 6-10 Two-wire operation mode 2

2: Three-wire control, integrate Enable with direction. At this mode, SIn is the Enable terminal with the direction controlled by the defined FWD and REV. But pulse is valid, and the STOP is achieved by disabling SIn terminal signal.

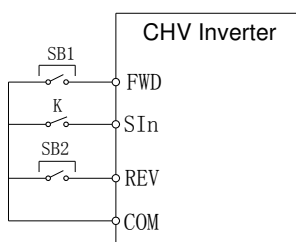

Figure 6-11 Three-wire operation mode

K: Disable switching

SB1: FWD button

SB2: REV button

SIn is defining the corresponding terminal function as Function 3 “Three-wire operation control”.

3: Three-wire control, separate Enable from direction. At this mode SIn is the Enable terminal, and FWD is the on-off control terminal, establishing two-stage Enable with direction determined by REV status. Pulse is valid. The diagram is shown in Figure 6-11.

Note: For two-wire operation mode, when FWD/REV terminal is enabled and the stop command produced by other sources stops the equipment, the inverter does not start to operate after the stop command disappears even if the control terminal FWD/REV is still valid. If the inverter needs to operate, it is required to trigger FWD/REV again. For instance, PLC single loop stop, fixed length stop, valid **STOP/RST stop under terminal operation command channel (P7.04).**

Function Code	Name	Description	setting range	Default Value
P5.14	Terminal UP/DOWN frequency increment change rate	0.01~50.00Hz/s	0.01~50.00	0.50Hz/s

Terminal UP/DOWN regulates the change rate of frequency setting.

Function Code	Name	Description	setting range	Default Value
P5.15	AI1 lower limit	0.00V~10.00V	0.00~10.00	0.00V
P5.16	AI1 lower limit corresponding setting	-100.0%~100.0%	-100.0~100.0	0.0%
P5.17	AI1 upper limit	0.00V~10.00V	0.00~10.00	10.00V
P5.18	AI1 upper limit	-100.0%~100.0%	-100.0~100.0	100.0%

	corresponding setting			
P5.19	AI1 input filtering time	0.00s~10.00s	0.00~10.00	0.10s

Above function codes define the relationship between analog input voltage and the setting value that analog input is corresponding to. When the analog input voltage exceeds the range of the set maximum or minimum input, the beyond portion should be calculated with maximum input or minimum input.

When analog input is amperage input, 0mA-20mA is corresponding to 0V-10V.

For different applications, the corresponding nominal value of analog setting 100.0% is different. For details, please refer to each application description.

Following figures shows several settings. Note: AI1 lower limit must be less or equal to AI1 upper limit.

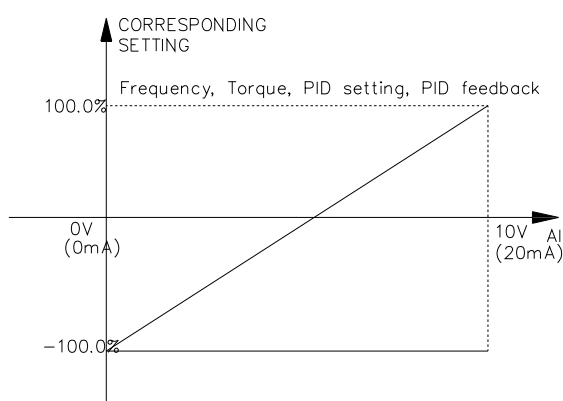

Figure 6-12 Relationship between analog input and setting value

AI1 input filtering time determines analog input sensitiveness. Increasing this parameter, in order to prevent malfunction caused by interference to the analog, can strengthen the anti-interference ability, but reduce the analog input sensitiveness.

Function Code	Name	Description	setting range	Default Value
P5.20	AI2 lower limit	0.00V~10.00V	0.00~10.00	0.00V
P5.21	AI2 lower limit corresponding setting	-100.0%~100.0%	-100.0~100.0	0.0%
P5.22	AI2 upper limit	0.00V~10.00V	0.00~10.00	10.00V
P5.23	AI2 upper limit corresponding setting	-100.0%~100.0%	-100.0~100.0	100.0%
P5.24	AI2 input filtering time	0.00s~10.00s	0.00~10.00	0.10s
P5.25	AI3 lower limit	-10.00V ~10.00V	-10.00~10.00	0.00V
P5.26	AI3 lower limit corresponding setting	-100.0%~100.0%	-100.0~100.0	0.0%
P5.27	AI3 upper limit	-10.00V ~10.00V	-10.00~10.00	10.00V
P5.28	AI3 upper limit corresponding setting	-100.0%~100.0%	-100.0~100.0	100.0%
P5.29	AI3 input filtering time	0.00s~10.00s	0.00~10.00	0.10s
P5.30	AI4 lower limit	0.00V~10.00V	0.00~10.00	0.00V
P5.31	AI4 lower limit corresponding setting	-100.0%~100.0%	-100.0~100.0	0.0%
P5.32	AI4 upper limit	0.00V~10.00V	0.00~10.00	10.00V

P5.33	A14 upper limit corresponding setting	-100.0%~100.0%	-100.0~100.0	100.0%
P5.34	A14 input filtering time	0.00s~10.00s	0.00~10.00	0.10s

A12, A13 and A14 function settings are similar to A11 setting method.

CHV inverter standard unit provides 2 paths of analog input port. Using A13 and A14 needs to install multifunction I/O extension card.

Function Code	Name	Description	setting range	Default Value
P5.35	HDI1 high speed pulse input function selection	0: setting input 1: counter input	0~4	0
P5.36	HDI2 high speed pulse input function selection	2: length counter input 3: Reserved 4: Reserved	0~4	0

P5.35 and P3.36 respectively define high speed pulse input functions

0: setting input. Correspond to the setting of frequency, torque, PID assignment, and PID feedback.

The settings coincidence relation is determined by function code P5.37-P5.46

1: counter input. Count pulse input

2: length counter input. Length count pulse input.

3-4: reserved

Function Code	Name	Description	setting range	Default Value
P5.37	HDI1 lower limit frequency	0.0 KHz ~ 50.0KHz	0.0~50.0	0.0KHz
P5.38	HDI1 lower limit frequency corresponding setting	-100.0%~100.0%	-100.0~100.0	0.0%
P5.39	HDI1 upper limit frequency	0.0 KHz ~ 50.0KHz	0.0~50.0	50.0KHz
P5.40	HDI1 upper limit frequency corresponding setting	-100.0%~100.0%	-100.0~100.0	100.0%
P5.41	HDI1 frequency input filtering time	0.00s~10.00s	0.00~10.00	0.10s
P5.42	HDI2 lower limit frequency	0.0 KHz ~ 50.0KHz	0.0~50.0	0.0KHz
P5.43	HDI2 lower limit frequency corresponding setting	-100.0%~100.0%	-100.0~100.0	0.0%
P5.44	HDI2 upper limit frequency	0.0 KHz ~ 50.0KHz	0.0~50.0	50.0KHz
P5.45	HDI2 upper limit frequency corresponding setting	-100.0%~100.0%	-100.0~100.0	100.0%
P5.46	HDI2 frequency input filtering time	0.00s~10.00s	0.00~10.00	0.10s

The ground of function codes defines the coincidence relation when pulse is used as the setting input mode. These functions are similar to A11 function.

P6. Output Terminal Group

CHV series inverter standard unit has one multifunction digital output terminal, two multifunction relay output terminals, one HDO terminal (can be used as either high speed pulse output terminal or open-collector output), and one multifunction analog output terminal. If it is required to add more relay output terminal and analog output terminal, please install

multifunction I/O extension card.

Multifunction I/O extension card adds one more multifunction relay output terminal and one more multifunction analog output terminal.

Function Code	Name	Description	setting range	Default Value
P6.00	HDO output selection	0: open-collector high speed pulse output 1: open-collector output	0~1	0

HDO terminal is programmable duplex terminal.

0: open-collector high speed pulse output: the maximum pulse frequency is 50.0 KHz.

See P6.09 for its associative function.

1: open-collector output: see P6.03 for its associative function

Function Code	Name	Description	setting range	Default Value
P6.01	Y1 output selection	Open collector output function	0~25	1
P6.02	Y2 output selection	Open collector output function	0~25	0
P6.03	HDO open collector output selection	Open collector output function	0~25	0
P6.04	Relay 1 output selection	Open collector output function	0~25	3
P6.05	Relay 2 output selection	Open collector output function	0~25	0
P6.06	Relay 3 output selection	Open collector output function	0~25	0

Open collector output functions are indicated as following table:

Setting Value	Function	Description
0	Zero Output	Output terminal has no function
1	Inverter is running forward.	Indicates the inverter is running forward with output frequency. Here output ON signal
2	Inverter is running reverse	Indicates the inverter is running reverse with output frequency. Here output ON signal
3	Fault output	Once inverter fault happens, output ON signal
4	Motor overload pre-warning	Before motor electronic thermal protection is active, it is judged according to predicted overload value. Once the pre-warning time is exceeded, output ON signal. Overload parameter is set up at PB.04-PB.06.
5	Inverter overload pre-warning	Based on inverter pre-warning point, once the pre-warning time is exceeded, output ON signal. Overload parameter is set up at PB.04-PB.06.
6	Frequency level detecting FDT reached	Please refer to the detail description of function code P8.25, P8.26
7	Frequency reached	Please refer to the detail description of function code P8.27
8	Null speed	When the inverter output frequency is less than the starting

Setting Value	Function	Description
	operation	frequency, output ON signal
9	Count pulse setting value reached	When the counting value is up to the setting of P8.22, output ON signal.
10	Assigned count pulse number reached	When the counting value reaches the setting value by P8.23, output ON signal. For Counting function, refer to FB Group function description.
11	Length reached	When the actual length detected exceeds the set value by P8.19, output ON signal.
12	PLC circulation completed	When the simple PLC operation finishes one circulation, output a pulse signal with a width 200ms.
13	Operating time reached	The cumulated operation time of inverter exceeds the time set by P8.24, output ON signal.
14	Upper limit frequency reached	When the operating frequency reaches the upper frequency limit, output ON signal.
15	Lower limit frequency reached	When the operating frequency reaches the lower frequency limit, output ON signal.
16	ready for operation	When the inverter is at ready status for operation with main circuit and control circuit power supplied and the inverter protection function not actuated, output ON signal.
17	Start boost motor 1	In the case of simple water supply system with one inverter driving three pumps, it is for the control of the two boost pumps. For its detail description, please refer to the descriptions of function code P8.29, P8.30 and P8.31
18	Start boost motor 2	
19~25	Reserved	Reserved

Function Code	Name	Description	setting range	Default Value
P6.07	AO1 output selection	Multifunction analog output	0~20	0
P6.08	AO2 output selection	Multifunction analog output	0~20	0
P6.09	HDO open collector high speed pulse output selection	Multifunction high speed pulse output	0~20	0

The standard analog output is 0-20mA (or 0-10V). Current or voltage output can be selected by Jumper J9. HDO open collector high speed pulse output range is set as 0 KHZ to 50.0 KHz.

Its corresponding value range is shown as following table:

Setting Value	Function	Range
0	Operating frequency	0-maximum output frequency
1	Setting frequency	0-maximum output frequency
2	Motor speed	0-double rated motor speed
3	Output current	0-double rated inverter current
4	Output voltage	0-double rated inverter voltage
5	Output power	0-double rated power

6	Output torque	0-double rated motor current
7	Analog AI1 input	0~10V
8	Analog AI2 input	0~10V/0~20mA
9	Analog AI3 input	0~10V
10	Analog AI4 input	0~10V
11	High speed pulse HDI1 input	0.1~50.0kHz
12	High speed pulse HDI2 input	0.1~50.0kHz
13	Length	0-set length (P8.19)
14	count value	0-set count value (P8.22)
15~20	Reserved	Reserved

Function Code	Name	Description	setting range	Default Value
P6.10	Lower output limit 1	0.0%~100.0%	0.0~100.0	0.0%
P6.11	Lower limit corresponding AO1 output	0.00V ~10.00V	0.00~10.00	0.00V
P6.12	Upper output limit 1	0.0%~100.0%	0.0~100.0	100.0%
P6.13	Upper limit corresponding AO1 output	0.00V ~10.00V	0.00~10.00	10.00V

Above function codes define the relationship between output value and analog output corresponding output value. When the output value exceeds the maximum output or the minimum output range, the beyond portion should be calculated with maximum output or minimum output.

When analog output is current output, 1mA is equivalent to 0.5V

For different applications, the analog output corresponding to 100% output value is different.

For details, please refer to the instruction of each application.

Following figures explain several setting circumstances:

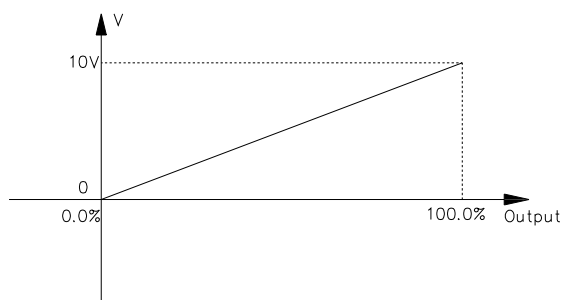

Figure 6-13 The coincidence relationship between assigned value and analog output

Function Code	Name	Description	setting range	Default Value
P6.14	Lower output limit 2	0.0%~100.0%	0.0~100.0	0.0%
P6.15	Lower limit corresponding AO2 output	0.00V ~10.00V	0.00~10.00	0.00V
P6.16	Upper output limit 2	0.0%~100.0%	0.0~100.0	100.0%
P6.17	Upper limit corresponding AO2 output	0.00V ~10.00V	0.00~10.00	10.00V
P6.18	Lower output limit 3	0.0%~100.0%	0.0~100.0	0.0%
P6.19	Lower limit corresponding HDO output	0.0 ~ 50.0kHz	0.0~50.0	0.0kHz
P6.20	Upper output limit 3	0.0%~100.0%	0.0~100.0	100.0%
P6.21	Upper limit corresponding HDO output	0.0 ~ 50.0kHz	0.0~50.0	50.0kHz

Its output coincidence relation is similar to AO1

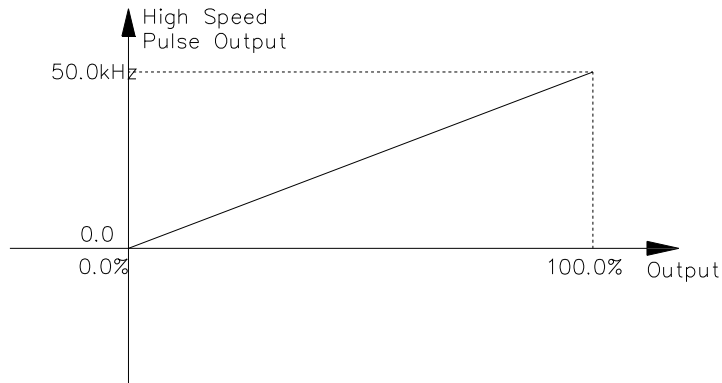

Figure 6-14 Coincidence relationship between assigned value and high speed pulse output

P7. Man-machine Interface Group

Function Code	Name	Description	setting range	Default Value
P7.00	User's password	0~65535	0~65535	0

As soon as it is set as any nonzero digit, cryptoguard function becomes effective.

00000: Clear user's password set before, and disables the cryptoguard function.

Since user's password is set up and becomes effective, the user can not enter into parameter menu if the user's password is not correct. Only when a correct user's password is input, the

user can see and modify the parameters. Please bear in mind the set user's password.

Function Code	Name	Description	setting range	Default Value
P7.01	LCD display language selection	0: Chinese 1: English	0~1	0

It is valid only when the inverter has LCD external keyboard. It is for selecting LCD display language.

Function Code	Name	Description	Setting range	Default Value
P7.02	Function parameter copying	0: no-operation 1: local keypad function parameters to LCD keyboard 2: LCD keyboard function parameters download to local keypad	0~2	0

This function code is to determine parameter copying mode. Parameter copying function is imbedded in LCD external keyboard.

1: Local keypad function parameters transmitted up to LCD keyboard: Local keypad function parameters are copied into LCD external keyboard.

2: LCD keyboard function parameters downloaded into Local keypad: Parameters in LCD external keyboard are copied into Local keypad.

Note: after 1-2 operations are completed, parameters are automatically cleared to zero.

Function Code	Name	Description	setting range	Default Value
P7.03	QUICK/JOG button function selection	0: shortcut menu QUICK function 1: FWD/REV switching 2: Jogging operation 3: clear UP/DOWN setting	0~3	0

The function of **QUICK/JOG** button, i.e. multifunction button, can be defined by means of **QUICK/JOG** parameter setting.

0: shortcut menu QUICK function: can visit shortcut menu. For details, please refer to shortcut function description.

1: FWD/REV switching: Keyboard **QUICK/JOG** button achieves switching the frequency command direction. It is only enabled when keyboard channel is used.

2: Jogging operation: Keyboard **QUICK/JOG** button realizes Jogging operation.

3: Clear UP/DOWN setting: Keyboard **QUICK/JOG** button clears the UP/DOWN setting value to zero.

Function Code	Name	Description	setting range	Default Value
---------------	------	-------------	---------------	---------------

P7.04	STOP/RST button stop function selection	0: valid only to panel control 1: valid to panel control and terminal control at the same time 2: valid to panel control and communication control at the same time 3: valid to all control modes	0~3	0
-------	---	--	-----	---

This function code is to define the **STOP/RST** stop function validity options. For fault reset, **STOP/RST** button is valid at any status.

Function Code	Name	Description	setting range	Default Value
P7.05	Keyboard display selection	0: external keyboard preferential enable 1: Local panel and external keyboard simultaneous display, only external keyboard key-press is valid. 2: Local panel and external keyboard simultaneous display, only Local key-press is valid. 3: Local panel and external keyboard simultaneous display, and all key-presses are valid (both are OR logical relation)	0~3	0

This function is to set up the logical relationship between Local keypad and external keyboard key-press display.

Important: No. 3 function should be used cautiously. Maloperation may cause serious consequences.

Function Code	Name	Description	setting range	Default Value
P7.06	Operation status display parameter selection	0~65535	0~65535	255

At operation status, CHV series inverter defaults to display five parameters, which are: 1. operation frequency 2. set frequency 3. bus voltage 4. output voltage 5. output current. Other parameters display is affected by this function code, i.e. one 16 bits binary digit. If one of the bits is 1, its corresponding parameter can be viewed at operation through button **»/SHIFT**. If the bit is 0, its corresponding parameter will not be displayed. When set up function code P7.06, it is required to convert the binary digit into decimal number to input this function code. The display content indicated by low 8 digits is described as following table:

BIT7	BIT6	BIT5	BIT4	BIT3	BIT2	BIT1	BIT0
Analog AI1 value	Output terminal status	Input terminal status	PID feedback value	PID given value	Output torque	Output power	Operating speed

The display content indicated by high 8 digits is described as following table:

BIT15	BIT14	BIT13	BIT12	BIT11	BIT10	BIT9	BIT8
Count value	Length	PLC and multi-speed operating stage number	Pulse frequency 2 (HDI2)	Pulse frequency 1 (HDI1)	Analog AI4 value	Analog AI3 value	Analog AI2 value

This I/O terminal status is displayed in decimal system, S1 (Y1) corresponding to the lowest digit. For instance, input status displays 10 is indicating that terminal S2 and S4 are

closed and others are open. For details, please see P7.09 and P7.20 description.

Function Code	Name	Description	setting range	Default Value
P7.07	Stop status display parameter selection	1~65535	1~65535	255

This function setting is the same as P7.06 setting. Only when CHV series inverter is at stop status, parameter display is affected by this function code.

Low 8 digits display as following table:

BIT7	BIT6	BIT5	BIT4	BIT3	BIT2	BIT1	BIT0
Analog AI3 value	Analog AI2 value	Analog AI1 value	PID given value	Output terminal status	Input terminal status	Bus voltage	Set frequency

High 8 digits display as following table:

BIT15	BIT14	BIT13	BIT12	BIT11	BIT10	BIT9	BIT8
Reserved	Reserved	Reserved	Length	Current stage number of PLC and multi-speed	Pulse frequency 2 (HDI2)	Pulse frequency 1 (HDI1)	Analog AI4 value

Function Code	Name	Description	setting range	Default Value
P7.08	Diode bridge module temperature	0~100.0℃		
P7.09	IGBT module temperature	0~100.0℃		
P7.10	MCU software version			
P7.11	DSP software version			
P7.12	Inverter accumulative operating time	0~65535h		

These functions only can be viewed but can not be modified.

Diode bridge module temperature: indicates the temperature of rectification module.

Over-temperature protection value of different inverter may be different.

IGBT module temperature: indicates the temperature of the inverter IGBT module.

Over-temperature protection value of different inverter may be different.

MCU software version: MCU software version number.

DSP software version: DSP software version number.

Inverter accumulative operating time: displays current inverter accumulative operation time. If the time reaches the setting operation time (P8.24), inverter multi-function digital output is actuated.

Function Code	Name	Description	setting range	Default Value
P7.13	Previous two fault type	0~27	0~27	
P7.14	Previous one fault type	0~27	0~27	
P7.15	Current fault type	0~27	0~27	

Recording three recent fault types: 0 is no fault; 1-27 is 27 different kinds of fault. For details, please see fault analysis.

Function Code	Name	Description	setting range	Default Value																				
P7.16	Current fault operating frequency	The output frequency when current fault happens																						
P7.17	Current fault output amperage	The output amperage when current fault happens																						
P7.18	Current fault bus voltage	The bus voltage when current fault happens																						
P7.19	Current fault input terminal status	<p>This value is decimal numbers, displaying all digital input terminal status at recent fault. The sequence is:</p> <table border="1" style="margin-left: 20px;"> <tr> <td>9</td><td>8</td><td>7</td><td>6</td><td>5</td><td>4</td><td>3</td><td>2</td><td>1</td><td>0</td> </tr> <tr> <td>S8</td><td>S7</td><td>S6</td><td>HDI2</td><td>HDI1</td><td>S5</td><td>S4</td><td>S3</td><td>S2</td><td>S1</td> </tr> </table> <p>If the input terminal of the time is ON, it is corresponding to 1, while OFF is to 0. Through this value, the digital input signal conditions at the time can be acknowledged.</p>	9	8	7	6	5	4	3	2	1	0	S8	S7	S6	HDI2	HDI1	S5	S4	S3	S2	S1		
9	8	7	6	5	4	3	2	1	0															
S8	S7	S6	HDI2	HDI1	S5	S4	S3	S2	S1															
P7.20	Current fault output terminal status	<p>This value is decimal numbers, displaying all digital input terminal status at recent fault. The sequence is:</p> <table border="1" style="margin-left: 20px;"> <tr> <td>BIT5</td><td>BIT4</td><td>BIT3</td><td>BIT2</td><td>BIT1</td><td>BIT0</td> </tr> <tr> <td>R03</td><td>R02</td><td>R01</td><td>HDO</td><td>Y2</td><td>Y1</td> </tr> </table> <p>If the input terminal of the time is ON, it is corresponding to 1, while OFF is to 0. Through this value, the digital output signal conditions at the time can be acknowledged.</p>	BIT5	BIT4	BIT3	BIT2	BIT1	BIT0	R03	R02	R01	HDO	Y2	Y1										
BIT5	BIT4	BIT3	BIT2	BIT1	BIT0																			
R03	R02	R01	HDO	Y2	Y1																			

P8. Enhancing Function Group

Function Code	Name	Description	setting range	Default Value
P8.00	Acceleration time 1	0.0~3600.0s	0.0~3600.0	20.0s
P8.01	Deceleration time 1	0.0~3600.0s	0.0~3600.0	20.0s
P8.02	Acceleration time 2	0.0~3600.0s	0.0~3600.0	20.0s
P8.03	Deceleration time 2	0.0~3600.0s	0.0~3600.0	20.0s
P8.04	Acceleration time 3	0.0~3600.0s	0.0~3600.0	20.0s
P8.05	Deceleration time 3	0.0~3600.0s	0.0~3600.0	20.0s

Acceleration/Deceleration time can be chosen to be P0.11, P0.12 or above three time settings. Their meanings are all the same; please refer to P0.11 and P0.12 related description.

The Acceleration/Deceleration time 0-3 at inverter operation can be chosen through different combination of multifunction digital input terminals.

Function Code	Name	Description	setting range	Default Value
P8.06	Jogging operation frequency	0.00~P0.07	0.00~ P0.07	5.00Hz
P8.07	Jogging operation Acceleration time	0.0~3600.0s	0.0~3600.0	20.0s
P8.08	Jogging operation Deceleration time	0.0~3600.0s	0.0~3600.0	20.0s

It is to define the inverter set frequency and Acceleration/Deceleration time at Jogging operation. START/STOP operation in the inching operation process is performed by direct start mode and Deceleration stop mode.

The Jogging Acceleration time is the time required for inverter to accelerate from 0Hz to the maximum output frequency (P0.07).

The Jogging Deceleration time is the time required for inverter to decelerate from the maximum output frequency (P0.07) to 0Hz.

Function Code	Name	Description	setting range	Default Value
P8.09	Skip frequency 1	0.00~P0.07	0.00~P0.07	0.00Hz
P8.10	Skip frequency 2	0.00~P0.07	0.00~P0.07	0.00Hz
P8.11	Skip frequency range	0.00~P0.07	0.00~P0.07	0.00Hz

When the set frequency is within the skip frequency range, the actual operating frequency will be operated near the boundary of skip frequency range.

By means of setting skip frequency, the inverter can keep away from the mechanical resonance point of the load. This inverter has two skip frequency points available. If these two skip frequencies are both set to 0, this function will be inactive.

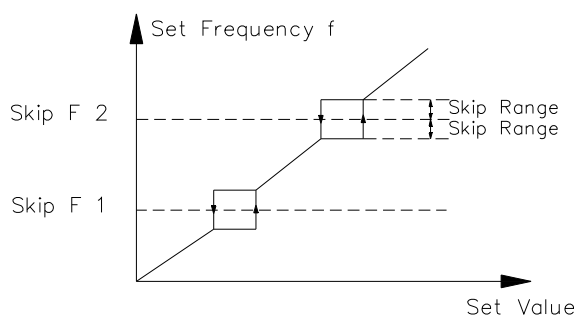

Figure 6-15 Skip frequency schematic diagram

Function Code	Name	Description	setting range	Default Value
P8.12	Traverse frequency range	0.0~100.0% (relative to set frequency)	0.0~100.0	0.0%

P8.13	Kick frequency range	0.0~50.0% (relative to traverse frequency range)	0.0~50.0	0.0%
P8.14	Traverse frequency raising time	0.1~3600.0s	0.1~3600.0	5.0s
P8.15	Traverse frequency fall time	0.1~3600.0s	0.1~3600.0	5.0s

Traverse frequency function is suitable to industries such as textile, fiber and so on, and to applications which require traversing and winding functions.

Traverse frequency function means that the inverter output frequency is traversing up and down around the set frequency. The operating frequency locus with time axis is shown as following diagram, in which the amplitude of traverse is set by P8.12. When P8.12 is set to be 0, i.e. traverse range is 0, the traverse frequency function will be inactive.

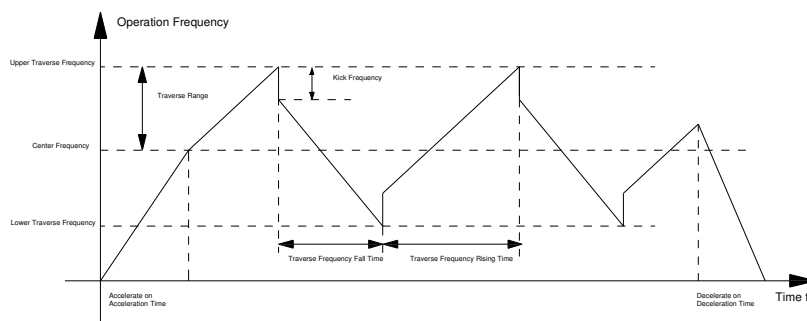

Figure 6-16 Traverse Frequency Operation Diagram

Traverse frequency range: traverse operation frequency limits by upper and lower limit frequency.

Traverse range relative to the center frequency: amplitude of traverse $AW = CF \times AW$ range P8.12

Kick frequency = amplitude of traverse $AW \times$ Kick Frequency Range P8.13. I.e. the kick frequency is the value relative to amplitude of traverse at traverse-frequency operation.

Traverse frequency rising time: the time required to rise from the lowest traverse frequency to the highest traverse frequency.

Traverse frequency fall time: the time required to fall from the highest traverse frequency to the lowest traverse frequency.

Function Code	Name	Description	setting range	Default Value
P8.16	fault auto-reset times	0~3	0~3	0
P8.17	Fault relay actuated during automatic fault resetting	0: inactive 1: active	0~1	0
P8.18	Interval time setting of automatic resetting fault	0.1~100.0s	0.1~100.0	1.0s

Fault auto-reset times: used to set the auto-reset times when inverter chooses fault

auto-reset. If this value is exceeded, inverter will wait for trouble shooting.

Fault relay is active during automatic fault resetting fault: when inverter fault auto-reset function is selected, during the period of resetting, it can be determined through this parameter setting, whether it is required for the fault relay to be actuated to shield the caused fault alarm, keeping the equipment continue running.

Interval time setting of fault auto-reset: chose the interval time between fault occurring and automatic resetting actuated

Important: after the fault is automatically reset, the inverter returns to its status before fault occurs. In the meanwhile, if fault has not occurred for ten minutes after the fault is reset, the system will automatically clear the previous times of fault-reset.

Function Code	Name	Description	setting range	Default Value
P8.19	Set Length	1~65535	1~65535	1000
P8.20	Actual Length	0~65535	0~65535	0
P8.21	Unit Pulse Number	0.1~6553.5	0.1~6553.5	100.0

The three function codes of Set Length, Actual Length and Unit Pulse Number are mainly used for fixed-length control.

The length is calculated with pulse signal input by on-off input terminal, and it is required that the responsive input terminal is set as the length count input terminal. Generally when the pulse frequency is high, it is required to use HDI1 or HDI2 input.

Actual Length = Length count input pulse number/unit pulse number

When the actual length P8.20 exceeds the set length P8.19, multifunction digital output terminal "Length Reached" outputs ON signal.

Function Code	Name	Description	setting range	Default Value
P8.22	Preset count value	1~65535	1~65535	1000
P8.23	Assigned count value	1~65535	1~65535	1000

The count value is counted in pulse signal input through the counter input terminal in the multifunction on-off input terminals.

When the count value reaches the set count value, the on-off output terminal outputs the signal that the preset count value is reached. The counter is cleared to zero and continue to count the next coming pulse.

When the count value reaches the assigned count value, the on-off output terminal outputs the signal that the set count value is reached. The counter continues counting until "preset count value" is reached. The counter is cleared to zero, and continues to count the next coming pulse.

The assigned count value P8.23 should not be bigger than the preset count value P8.22.

This function is shown as following figure.

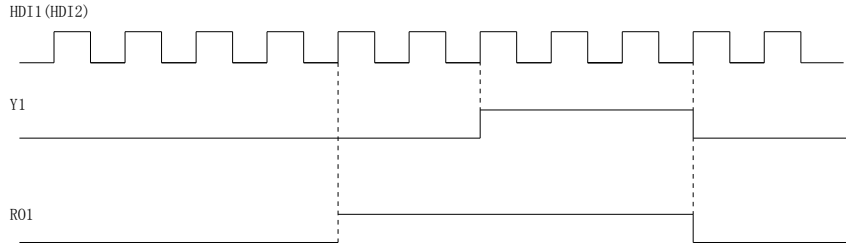

Figure 6-17 Preset count value setting and assigned value setting diagram

Function Code	Name	Description	setting range	Default Value
P8.24	Set operating time	0~65535h	0~65535	65535 h

Preset the inverter operation time

When the accumulated operation time reaches the set operation time, the inverter multifunction digital output outputs the signal that the time is reached.

Function Code	Name	Description	setting range	Default Value
P8.25	FDT level detection value	0.00~ P0.07	0.00~ P0.07	50.00Hz
P8.26	FDT delay detection value	0.0~100.0%	0.0~100.0	5.0%

Set output frequency detection value and the delay value of output action dismissed, as shown by following figure:

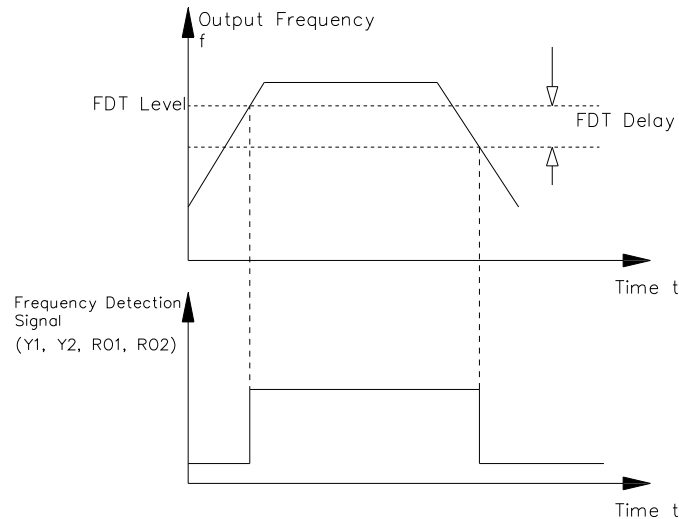

Figure 6-18 FDT Level Diagram

Function Code	Name	Description	setting range	Default Value
P8.27	Frequency reaching detection range	0.0~100.0% (maximum frequency)	0.0~100.0	0.0%

When the inverter output frequency reaches the set frequency value, this function can regulate its detection range value, as shown by following figure:

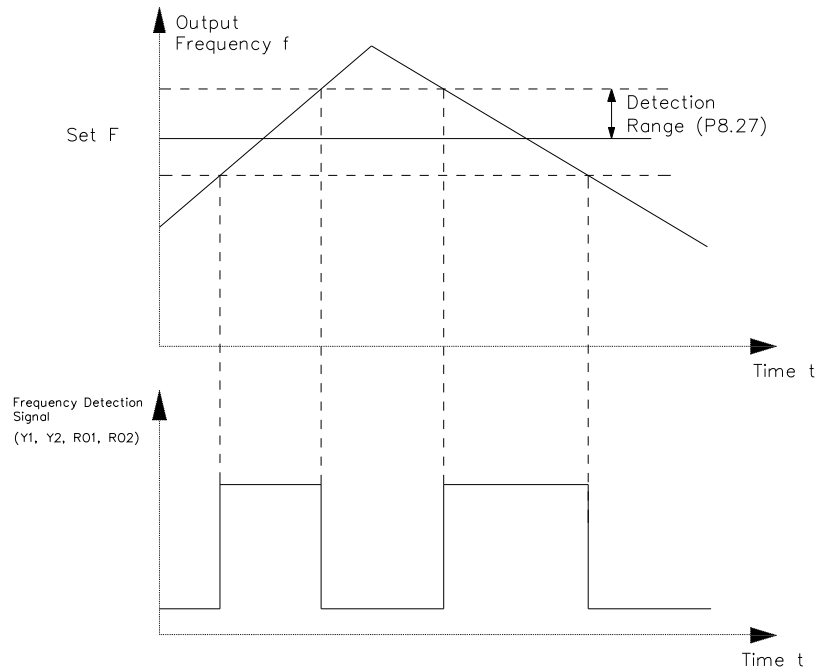

Figure 6-19 Frequency Reaching Detection Range Diagram

Function Code	Name	Description	setting range	Default Value
P8.28	Droop control	0.00~10.00Hz	0.00~10.00	0.00Hz

When multiple inverters drive one same load, uneven load distribution can be caused because of different speed, and the inverter that has bigger speed undertakes heavier load.

This parameter adjusts the frequency variation of inverter which gets speed sagging.

Function Code	Name	Description	setting range	Default Value
P8.29	Boost motor validity selection	0: No boost motor 1: Boost motor 1 valid 2: Boost motor 2 valid 3: Boost motor 1 and 2 valid	0~3	0
P8.30	Boost motor 1 START/STOP delay time	0.0~3600.0s	0.0~3600.0	5.0s
P8.31	Boost motor 2 START/STOP delay time	0.0~3600.0s	0.0~3600.0	5.0s

Above three function codes are used for achieving one inverter drive three pumps simple water supply function. One variable frequency pump and two power frequency pumps (boost pumps) constitute the simple constant pressure water supply system. Its correlated logic is shown as following figure:

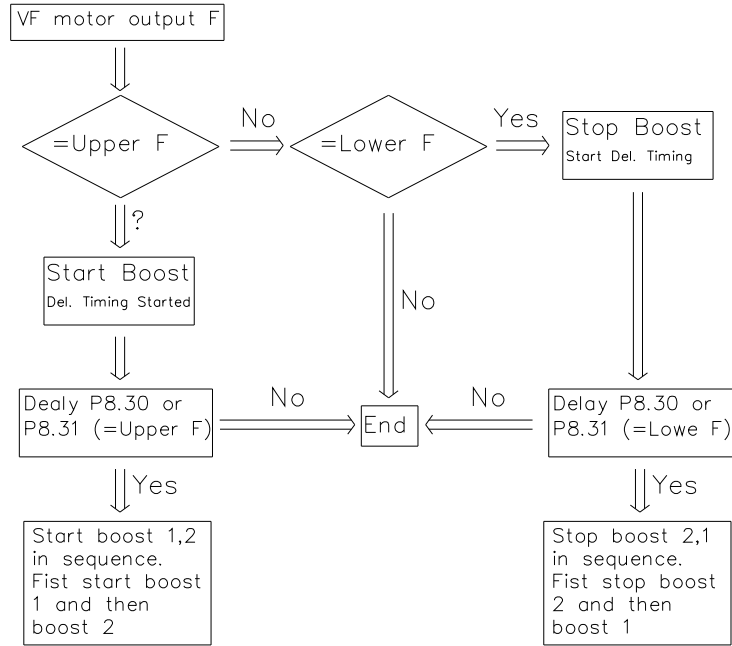

Function Code	Name	Description	setting range	Default Value
P8.32	Brake Threshold Voltage	550.0~750.0V	550.0~750.0	700.0V

This function is to set up the initiative bus voltage of dynamic braking, and properly regulating this value can result in an effective brake to the load.

Function Code	Name	Description	setting range	Default Value
P8.33	Reserved Function	0~65535	0~65535	0
P8.34	Reserved Function	0~65535	0~65535	0

P9. PID Control Group

PID control is one method normally used to process control, holding the control value to the target value by the negative feedback system which regulates the inverter output frequency by means of proportion, integration and differential operations on the difference between the control value feedback signal and the target value signal. It is applicable to the process controls such as flow control, pressure control and temperature control and so on. The control functional block diagram is shown as follows,

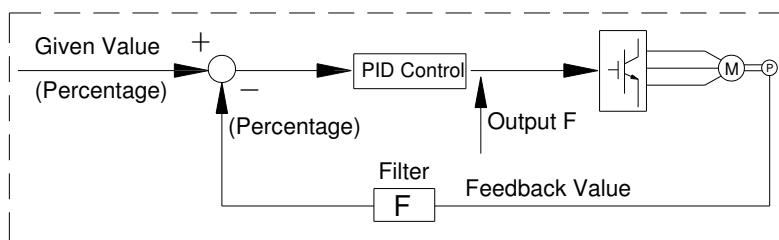

Figure 6-20 Process PID Functional Block Diagram

Function Code	Name	Description	setting range	Default Value
P9.00	PID Assignment Sources selection	0: Given by Keyboard (P9.01) 1: Given by Analog Channel AI1 2: Given by Analog Channel AI2 3: Given by Analog Channel AI3 4: Given by Analog Channel AI4 5: Pulse Frequency Assignment 1 (HD11)	0~8	0

		6: Pulse Frequency Assignment 2 (HDI2) 7: Given by Remote Communication 8: Multistage Assignment		
--	--	--	--	--

When frequency source is chosen to be PID, i.e. P0.03 is chosen to be 6, these group functions are active. This parameter is to determine the assignment channel of the process PID target value.

The set target value of process PID is a relative value, and the set 100% is corresponding to the 100% feedback signal of the system being controlled.

The system always performs the calculation according to relative value (0-100%)

Note: If multistage input, it can be accomplished by means of setting PA group parameters.

Function Code	Name	Description	setting range	Default Value
P9.01	Keyboard preset PID Assignment	-100.0%~100.0%	-100.0~100.0	0.0%

When P9.00=0 is chosen, i.e. the target source is the keyboard, it is required to set this parameter.

The reference value of this parameter is the system feedback value.

Function Code	Name	Description	setting range	Default Value
P9.02	PID Feedback Sources selection	0: Analog Channel AI1 Feedback 1: Analog Channel AI2 Feedback 2: Analog Channel AI3 Feedback 3: Analog Channel AI4 Feedback 4: AI1-AI2 Feedback 5: AI3-AI4 Feedback 6: Pulse Frequency Feedback 1 (HDI1) 7: Pulse Frequency Feedback 2 (HDI2) 8: HDI1-HDI2 Feedback 9: Remote Communication Feedback	0~9	0

The PID feedback channel is chosen by this parameter.

Important: The assignment channel and feedback channel can not be in coincidence, otherwise PID is unable to control effectively.

Function Code	Name	Description	setting range	Default Value
P9.03	PID Output Characteristics selection	0: PID output is positive characteristic 1: PID output is negative characteristic	0~1	0

PID output is positive characteristic: when the feedback signal is bigger than the PID given signal, it is required for the inverter output frequency to decrease to counterbalance the PID, for instance, the winding tension PID control.

PID output is negative characteristic: when the feedback signal is bigger than the PID giver signal, it is required for the VFD output frequency to increase to counterbalance the PID, for instance, the unreeling tension PID control.

Function	Name	Description	setting range	Default
----------	------	-------------	---------------	---------

Code				Value
P9.04	Proportional gain (Kp)	0.00~100.00	0.00~100.00	0.10
P9.05	Integrating time (Ti)	0.01~10.00s	0.01~10.00	0.10s
P9.06	Derivative time (Td)	0.00~10.00s	0.00~10.00	0.00s

Proportional gain (Kp): determines the adjusting strength of PID adjustor. The bigger the P, the bigger the adjusting strength is. This parameter being 100 means that when the difference between the PID feedback value and the assigned value is 100%, the adjusting range of PID adjustor to the output frequency command is the maximum frequency (ignore integral action and derivative action).

Integrating time (Ti): determines the speed at which PID adjustor performs integral regulation to the discrepancy between the PID feedback value and the assigned value. The Ti is indicating the period of time that integral controller (ignore proportional action and derivative action), when the discrepancy between the PID feedback value and the assigned value is 100%, continuously regulates to make the regulating amount to reach the maximum frequency (P0.07). The shorter the integrating time, the stronger the adjusting strength is.

Differential time (Td): determines the controlling strength at which PID adjustor performs adjustment to the variance ratio of discrepancy between the PID feedback value and the assigned value. The Td is indicating the period of time within which if the feedback value is changed 100%, the regulating amount of integral controller is the maximum frequency (P0.07) (ignore proportional action and integral action). The longer the Td, the bigger the controlling strength is.

PID is the most popularly used control mode in process control, with each part playing different role. Following simply introduces the operational principle and the controlling method:

Proportion control (P): when there is discrepancy between feedback and the assignment, output the regulating amount in proportion to the discrepancy. If the discrepancy is constant, the regulating amount keeps constant. Proportion control can response quickly to the feedback variation, but only using proportion control is unable to perform noncorresponding control. The bigger the proportional gain, the faster the system regulating speed, but being too big may cause oscillation. The control method is first to set a long integrating time and a zero differential time, and then run the system only by using proportion control. Change the assigned value, and watch the stable discrepancy (steady-state error) of feedback signal and assigned value. If the steady-state error is at the varying direction of assigned value (for instance, increase the assigned value, the feedback value after the system is steady is always less than the assigned value), continue to increase the proportional gain, otherwise decrease it. Repeat the above until the steady-state error is relatively small (it is very difficult to do no steady-state error).

Integral time (I): when there is a discrepancy between the feedback and assignment, continuously accumulate the output regulation amount. If the discrepancy still exists, continue to increase the regulation amount until there is no discrepancy. Integral controller can effectively eliminate the steady-state error. Integral controller being too strong can cause repeated overshooting, system unstable and up till oscillating. The characteristic of oscillation caused by too strong integral action is that the feedback signal is swinging up and down around the assigned value, and the amplitude of swing increases gradually till the oscillation

happens. Normally the integral time is adjusted from big to small, gradually regulate the integral time, and watch the effect, until the system stable speed meets requirements.

Differential time (D): when the discrepancy between feedback and assignment varies, output a regulation amount in proportion to the variance ratio of discrepancy. The regulation amount is related to the direction and magnitude of discrepancy variation, but irrelevant to the direction and value of the discrepancy itself. The differential control action is to perform the control according to the varying trend when the feedback signal variation happens, and thereby to restrain the feedback signal variation. It should be caution to use differential controller as the differential control have a trend to magnify the system interference, especially the high varying frequency interference.

Function Code	Name	Description	Setting range	Default Value
P9.07	Sampling time (T)	0.01~100.00s	0.01~100.00	0.50s
P9.08	PID control discrepancy limit	0.0~100.0%	0.0~100.0	0.0%

Sampling time (T): is the time to sample the feedback value. In each sampling period the controller runs one time. The longer the sampling time, the slower the responding.

PID control discrepancy limit: the allowable maximum discrepancy of PID system output value relative to the closed-loop assigned value. As shown in following diagram, within the discrepancy limit, PID controller stops adjustment. Properly setting this function code can improve the accuracy and stability of PID system.

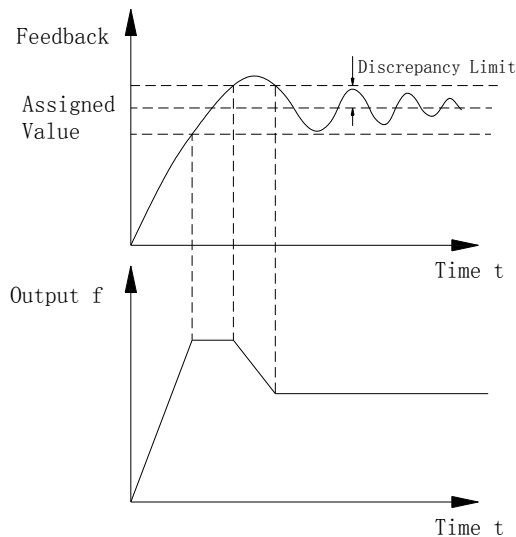

Figure 6-21 Coincidence relation of discrepancy limit and output frequency

Function Code	Name	Description	Setting range	Default Value
P9.09	PID output buffering time	0.00~10.00s	0.00~10.00	0.00

PID output buffering time: filter the analog input signal to prevent frequently jumping interference signal producing impact on the system. But filtering time being too long can affect

regulating sensitivity.

Function Code	Name	Description	Setting range	Default Value
P9.10	Feedback disconnected detecting value	0.0~100.0%	0.0~100.0	0.0%
P9.11	Feedback disconnected detecting time	0.0~3600.0s	0.0~3600.0	10.0s

Feedback disconnected detecting value: this detecting value is relative to the full range (100%). The system detects the PID feedback value all the time. When the feedback value is less or equal to the feedback disconnected detecting value, the system starts to time the detection. When the detecting time exceeds the feedback disconnected detecting time, the system will send an alert of feedback disconnecting failure.

PA. Simple PLC and Multi-Speed Control Group

Simple PLC function is that a programmable logic controller (PLC) which is built-in the inverter performs the automatic control on the multistage frequency logic. Operation time, operation direction and operation frequency can be set to meet the process requirements.

This series inverter can perform 16 stages speed variation control with 4 kinds of Acceleration/Deceleration time available to be chosen.

After the set PLC completes a control loop, an ON signal can be output by multifunction digital output terminal or by multifunction relay.

Function Code	Name	Description	Setting range	Default Value
PA.00	Simple PLC operation mode	0: Stop after running once 1: keep running at the final value after running once 2: running in cycle	0~2	0

0: stop after run once. The inverter automatically stops as soon as it completes one single loop, and it is needed to send it operating command for it to start again.

1: keep running at the final value after running once. The inverter automatically keeps the operating frequency and direction after completing one single control loop.

2: Running in cycle. After one loop is finished, the inverter automatically goes to run next control loop until there is a stop command to stop the system.

Function Code	Name	Description	setting range	Default Value
PA.01	Multistage operation memory selection	0: no memory while power down 1: memorize while power down	0~1	0

PLC power-down memory means memorizing the PLC operating stage and operating frequency before power-down.

Function Code	Name	Description	Setting range	Default Value
PA.02	Multi-Speed 0	-100.0~100.0%	-100.0~100.0	0.0%
PA.03	0 th Stage operating time	0.0~6553.5s(h)	0.0~6553.5	0.0s
PA.04	Multi-Speed 1	-100.0~100.0%	-100.0~100.0	0.0%
PA.05	1 st Stage operating time	0.0~6553.5s(h)	0.0~6553.5	0.0s
PA.06	Multi-Speed 2	-100.0~100.0%	-100.0~100.0	0.0%
PA.07	2 nd Stage operating time	0.0~6553.5s(h)	0.0~6553.5	0.0s
PA.08	Multi-Speed 3	-100.0~100.0%	-100.0~100.0	0.0%
PA.09	3 rd Stage operating time	0.0~6553.5s(h)	0.0~6553.5	0.0s
PA.10	Multi-Speed 4	-100.0~100.0%	-100.0~100.0	0.0%
PA.11	4 th Stage operating time	0.0~6553.5s(h)	0.0~6553.5	0.0s
PA.12	Multi-Speed 5	-100.0~100.0%	-100.0~100.0	0.0%
PA.13	5 th Stage operating time	0.0~6553.5s(h)	0.0~6553.5	0.0s
PA.14	Multi-Speed 6	-100.0~100.0%	-100.0~100.0	0.0%
PA.15	6 th Stage operating time	0.0~6553.5s(h)	0.0~6553.5	0.0s
PA.16	Multi-Speed 7	-100.0~100.0%	-100.0~100.0	0.0%
PA.17	7 th Stage operating time	0.0~6553.5s(h)	0.0~6553.5	0.0s
PA.18	Multi-Speed 8	-100.0~100.0%	-100.0~100.0	0.0%
PA.19	8 th Stage operating time	0.0~6553.5s(h)	0.0~6553.5	0.0s
PA.20	Multi-Speed 9	-100.0~100.0%	-100.0~100.0	0.0%
PA.21	9 th Stage operating time	0.0~6553.5s(h)	0.0~6553.5	0.0s
PA.22	Multi-Speed 10	-100.0~100.0%	-100.0~100.0	0.0%
PA.23	10 th Stage operating time	0.0~6553.5s(h)	0.0~6553.5	0.0s
PA.24	Multi-Speed 11	-100.0~100.0%	-100.0~100.0	0.0%
PA.25	11 th Stage operating time	0.0~6553.5s(h)	0.0~6553.5	0.0s
PA.26	Multi-Speed 12	-100.0~100.0%	-100.0~100.0	0.0%
PA.27	12 th Stage operating time	0.0~6553.5s(h)	0.0~6553.5	0.0s
PA.28	Multi-Speed 13	-100.0~100.0%	-100.0~100.0	0.0%
PA.29	13 th Stage operating time	0.0~6553.5s(h)	0.0~6553.5	0.0s
PA.30	Multi-Speed 14	-100.0~100.0%	-100.0~100.0	0.0%
PA.31	14 th Stage operating time	0.0~6553.5s(h)	0.0~6553.5	0.0s
PA.32	Multi-Speed 15	-100.0~100.0%	-100.0~100.0	0.0%
PA.33	15 th Stage operating time	0.0~6553.5s(h)	0.0~6553.5	0.0s

Frequency setting 100.0% is corresponding to the maximum frequency (P0.07).

When it is set as PLC operation mode, it is required to set PA.02-PA.33 to define its characteristic.

Note: The multi-speed symbol defines the operation direction of simple PLC. If it is negative, the operation direction is reverse.

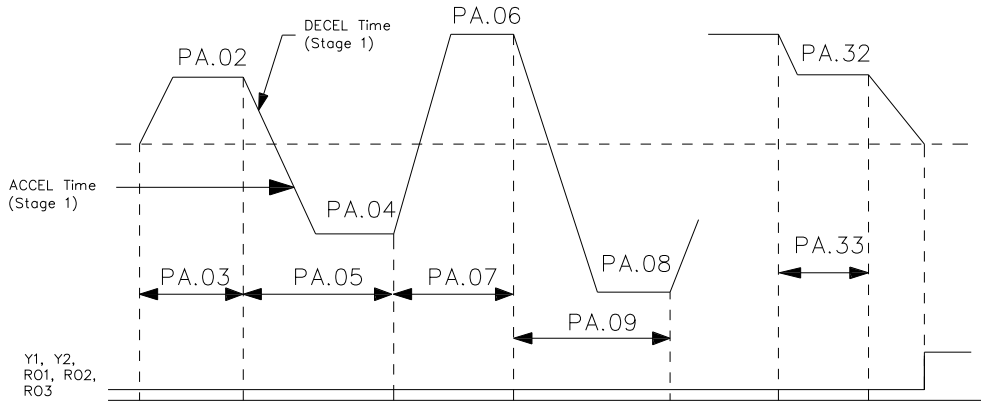

Figure 6-22 Simple PLC Schematic Diagram

Function Code	Name	Description	Setting range	Default Value
PA.34	Simple PLC Stage 0-7 ACCEL/DECEL Time Selection	0~65535	0~65535	0
PA.35	Simple PLC Stage 8-15 ACCEL/DECEL Time Selection	0~65535	0~65535	0

Details are described as following table

Function Code	Binary Digit		Stage No.	ACCEL/DECEL Time 0	ACCEL/DECEL Time 1	ACCEL/DECEL Time 2	ACCEL/DECEL Time 3
PA.34	BIT1	BIT0	0	00	01	10	11
	BIT3	BIT2	1	00	01	10	11
	BIT5	BIT4	2	00	01	10	11
	BIT7	BIT6	3	00	01	10	11
	BIT9	BIT8	4	00	01	10	11
	BIT11	BIT10	5	00	01	10	11
	BIT3	BIT12	6	00	01	10	11
PA.35	BIT15	BIT14	7	00	01	10	11
	BIT1	BIT0	8	00	01	10	11
	BIT3	BIT2	9	00	01	10	11
	BIT5	BIT4	10	00	01	10	11

BIT7	BIT6	11	00	01	10	11
BIT9	BIT8	12	00	01	10	11
BIT11	BIT10	13	00	01	10	11
BIT3	BIT12	14	00	01	10	11
BIT15	BIT14	15	00	01	10	11

After the user chooses the ACCEL and DECEL time for relevant stages, convert the combined 16 digit binary number into decimal number, and then set up the relevant function code.

Function Code	Name	Description	Setting range	Default Value
PA.36	Multistage Time Unit Selection	0: Second 1: Hour	0~1	0

It is to define the operation time unit for each stage of the 16 stages procedure.

Pb. Protection Parameters Group

Function Code	Name	Description	Setting range	Default Value
Pb.00	Input phase-fault protection	0: prohibit protection 1: Allow protection	0~1	1
Pb.01	Output phase-fault protection	0: prohibit protection 1: Allow protection	0~1	1

Input phase-fault protection: to choose whether or not to protect the input phase-fault conditions.

Output phase-fault protection: to choose whether or not to protect the output phase-fault conditions.

Function Code	Name	Description	Setting range	Default Value
Pb.02	Motor Overloading Protection Option	0: No protection 1: general motor (with low speed compensation) 2: Variable Frequency motor (without low speed compensation)	0~2	1

0: no protection. There is no motor overloading protection characteristic (caution to use), and thereby the inverter has no protection to the overloaded motor.

1: general motor (with low speed compensation). As general motor has a poor heat emission at low speed, the relevant electronic thermal protection should be regulated properly. The low speed compensation characteristic here mentioned is to switch down the overloading protection threshold for the motor with an operation frequency lower than 30 Hz.

2: Variable frequency motor (without low speed compensation). As the heat emission of special variable frequency motor is not affected by speed, it is not required to regulate the protection value for low speed operation.

Function Code	Name	Description	Setting range	Default Value
Pb.03	Motor Overloading Protection Current	20.0%~120.0%	20.0~120.0	100.0%

The value can be determined by following equation:

$$\text{Motor overload protection current} = (\text{the allowed maximum overload current} / \text{inverter rated current}) * 100\%$$

It is mainly applied to the cases that big inverter drives small motor, requiring to correctly set up this function to protect the motor.

Function Code	Name	Description	Setting range	Default Value
Pb.04	Overload pre-warning point	20.0%~150.0%	20.0~150.0	130.0%
Pb.05	Overload pre-warning option	0: relative to motor rated current, detected all the time 1: relative to motor rated current, detected when speed is constant 2: relative to inverter rated current, detected all the time 3: relative to inverter rated current, detected when speed is constant	0~3	0
Pb.06	Overload pre-warning delay time	0.0~30.0s	0.0~30.0	5.0s

Overload pre-warning option: determines the warning category, such as inverter overload (OL1) and motor overload (OL2).

Overload pre-warning point: it is the current threshold when overload pre-warning is triggered, and it is set as the percentage relative to the rated current.

Overload pre-warning delay time: inverter output current is more than overload pre-warning point, and if the duration exceeds the overload pre-warning delay time, output a pre-warning signal. It is illuminated as following figure:

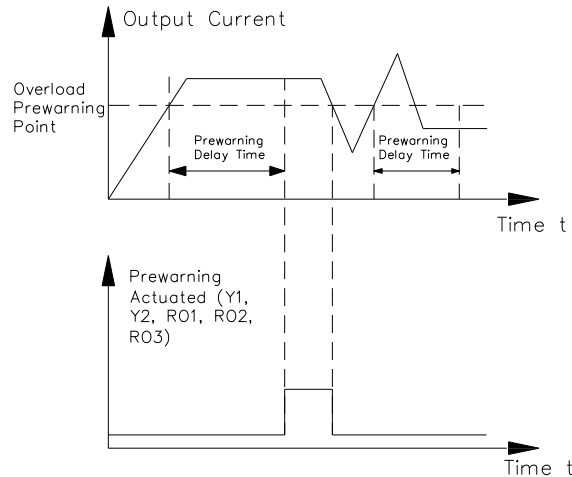

Figure 6-23 Overload Pre-warning actuation Schematic Diagram

Function Code	Name	Description	setting range	Default Value
Pb.07	Instant Power-down Frequency Drop Point	400.0V~600.0V	400.0~600.0	450.0V
Pb.08	Instant Power-down Frequency drop rate	0.00Hz~P0.07	0.00Hz~P0.07	0.00Hz

If the instant power-down drop rate is set to be 0, the instant power-down restart function is invalid.

Instant power-down frequency drop point: it is indicating when the bus voltage, after the power network is down and drops to the instant power-down frequency drop point, the inverter starts to decrease the operation frequency based on the instant power-down frequency drop rate, enabling the motor to generate electricity which is fed back to keep the bus voltage, and thus ensuring the inverter is operating normally till inverter power is on again.

Important: Adjusting these two parameters properly can magnificently achieve the power network switching instead of causing inverter protection and thus causing production shutdown.

Function Code	Name	Description	setting range	Default Value
Pb.09	Over-voltage Stall Protection	0: prohibit protection 1: allow protection	0~1	0
Pb.10	Over-voltage Stall Protection Voltage	120~150%	120~150	130%

During the inverter deceleration, the load inertia may cause the actual motor speed drop rate lower than the output frequency drop rate, and thereby the motor generates electricity and feeds it back to the inverter, causing the inverter bus voltage going up and even bus over-voltage breakdown which then can cause inverter tripping if no provision is made.

Over-voltage stall protection function is to detect the bus voltage and compare it with the stall over-voltage point defined by Pb.10 (relative to the standard bus voltage). If it exceeds the over-voltage stall point, inverter output frequency stop going down, and when the next bus

voltage detected is lower than the over-voltage stall point, the inverter continues to decelerate, as shown by following figure:

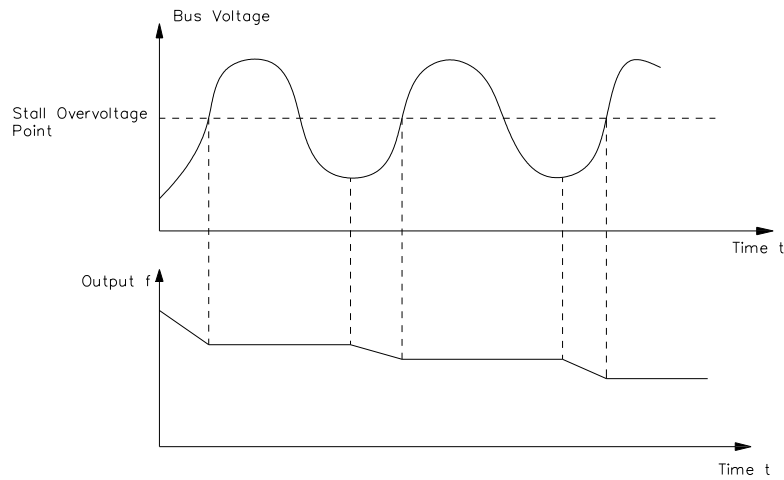

Figure 6-24 Over-voltage Stall Function

Function Code	Name	Description	setting range	Default Value
Pb.11	Over-current Stall Protection	0: prohibit 1: allowed	0~1	0
Pb.12	Over-current stall protection current ratio	100~200%	100~200	150%
Pb.13	Over-current Frequency Drop Rate	0.00~ 50.00Hz/s	0.00~50.00	0.00Hz/s

During inverter acceleration, the load is so big that the actual motor speed increase rate is lower than the output frequency increase rate, causing the ACCEL over-current breakdown which then could cause inverter tripping if no provision is made.

Over-current stall protection function is to detect the output current and compare it with the stall over-current point defined by PB.12. If it exceeds the stall over-current point, the inverter output frequency decreases at the over-current frequency drop rate (Pb.13), and when the next output current detected is lower than the over-current stall point, the inverter continues to accelerate, as shown by following figure:

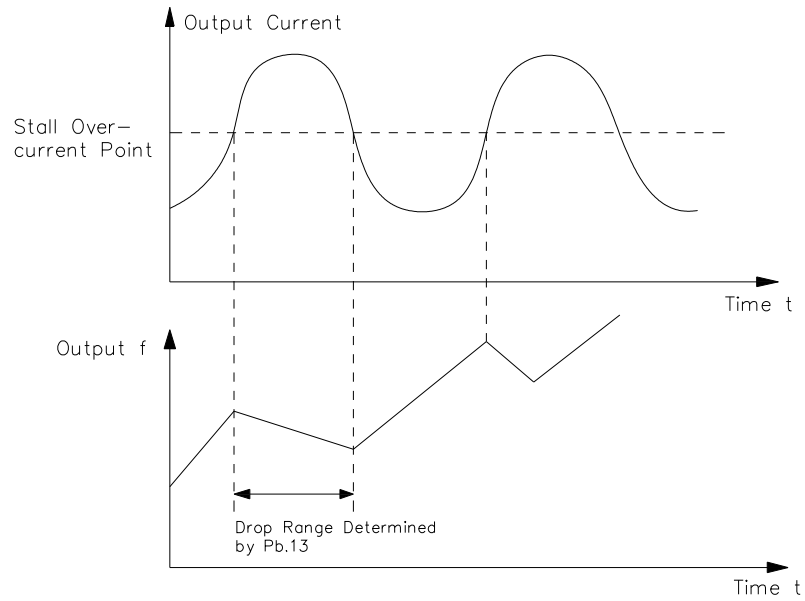

Figure 6-25 Over-current Stall Function

PC. Serial Communication Group

For details, please refer to “CHV Series Inverter Serial Communication Protocol Description”

PD. Reserved Function Group

This group is the reserved function group.

PE. Factory-set Function Group

This group is the factory-set parameter group. The user DO NOT try to open these group parameters otherwise will cause the inverter abnormal operation or damage.

7. Failure Inspection and Elimination

7.1 Failure Information and Elimination

Failure Code	Failure Type	Possible Failure Reason	Solution
OUT1	IGBT Ph-U Fail	<ol style="list-style-type: none"> 1. Accelerate too fast 2. IGBT of this Phase internal damaged 3. Failure action caused by interfere 4. Check the ground is in good condition or not 	Add more acceleration time for technical support Inspect the external equipment to ensure there is interfere source or not
OUT2	IGBT Ph-V Fail		
OUT3	IGBT Ph-W Fail		
OC1	Acc Overcurrent	<ol style="list-style-type: none"> 1. Accelerate too fast 2. Main voltage is lower 3. The capacity of this inverter is not enough 	<ol style="list-style-type: none"> 1 Add more acceleration time 2. Inspect the input main power 3. Select more powerful inverter
OC2	Dec Overcurrent	<ol style="list-style-type: none"> 1. Decelerate too fast 2. Inertia Torque of load is too large 3. The capacity of this inverter is not enough 	<ol style="list-style-type: none"> 1. Add more deceleration time 2. Add suitable external brake unit 3. Select more powerful inverter
OC3	Run Overcurrent	<ol style="list-style-type: none"> 1. Jump or abnormality of load 2. The main voltage is lower 3. The capacity of this inverter is not enough 	<ol style="list-style-type: none"> 1. Inspect the load or decrease the abrupt change of load 2. Inspect the input power 3. Select more powerful inverter
OV1	Acc Overvoltage	<ol style="list-style-type: none"> 1. Input voltage abnormality 2. Re-start the running motor after instant power failure 	<ol style="list-style-type: none"> 1. Inspect input power 2. Avoid stop then re-start.
OV2	Dec Overvoltage	<ol style="list-style-type: none"> 1. Deceleration too fast 2. Load inertia too large 3. Input voltage abnormality 	<ol style="list-style-type: none"> 1. Decrease the deceleration time 2. Add more brake unit 3. Inspect input power
OV3	Run Overvoltage	<ol style="list-style-type: none"> 1. Input voltage abnormality changed 2. Load inertia too large 	<ol style="list-style-type: none"> 1. Install input reactor 2. Add suitable external brake unit
UV	UV of Bus Line	<ol style="list-style-type: none"> 1. The mains voltage is low. 	<ol style="list-style-type: none"> 1. Inspect the input mains power
OL1	Motor Overload	<ol style="list-style-type: none"> 1. The mains voltage is too low. 2. The motor rated current is set up improperly 3. The motor has locked rotor or load sudden change is too big 4. The inverter's capacity is much large than the motor's 	<ol style="list-style-type: none"> 1. Examine the voltage of the power network 2. Re-setup the motor current rating 3. Check the load, adjust the torque lifting capacity 4. Chose proper motor
OL2	Invert Overload	<ol style="list-style-type: none"> 1. Accelerate too fast 2. Restart the motor while it is rotating 3. The voltage of the power network is too low 4. Too big load 	<ol style="list-style-type: none"> 1. Reduce the acceleration 2. Avoid restart the motor after stop is just pressed 3. Examine the voltage of the power network 4. Chose inverter having a higher horsepower
SPI	Input phase fail	Phase loss of input phases R, S, T.	<ol style="list-style-type: none"> 1. Check the input power supply 2. Check the wiring
SPO	Output ph fail	<ol style="list-style-type: none"> 1. Output phase loss of phases U, V, W (or serious asymmetry of the three loading phases) 2. Without motor, pre-excitation is failure to end during pre-excitation period 	<ol style="list-style-type: none"> 1. Inspect output wiring 2. Inspect motor and cables

OH1	Diode Over Heat	<ol style="list-style-type: none"> 1. Inverter instant over current 2. Short circuit between the three phases or grounding short circuit 3. Ducting block up or fan damaged 4. Too high ambient temperature 5. Loose connection of control panel wire or loose plug-in unit 6. Auxiliary power supply failure, under-driving-voltage. 	<ol style="list-style-type: none"> 1. Please see Over Current Solution 2. Rewiring 3. Clean the ducting or replace the fan. 4. Reduce the ambient temperature. 5. Inspect and re-connect 6. Ask for service. 7. Ask for service. 8. Ask for service.
OH2	IGBT Over Heat	<ol style="list-style-type: none"> 7. Power module bridge arm directly connected 8. Control panel malfunction 	
EF	External Failure	<ol style="list-style-type: none"> 1. SI external failure input terminal activated 	<ol style="list-style-type: none"> 1. Check external device input
CE	Comm Failure	<ol style="list-style-type: none"> 1. Baud rate improperly setup. 2. Miscommunication of applied serial communication. 3. Long time interrupt of communication. 	<ol style="list-style-type: none"> 1. Properly set up the baud rate. 2. Press Button STOP/RST to reset, and ask for service 3. Inspect communication interface wiring
ITE	Curr Detect Fail	<ol style="list-style-type: none"> 1. Poor connection of control panel connector. 2. Auxiliary power-supply failure. 3. Hall sensor failure. 4. Amplifying circuit failure. 	<ol style="list-style-type: none"> 1. Inspect connector, re-plug in. 2. Ask for service. 3. Ask for service. 4. Ask for service.
TE	Motor learn fail	<ol style="list-style-type: none"> 1. Mismatch of motor and inverter. 2. Improper setup of motor rated parameters. 3. Too big discrepancy of parameters from autotune and standard parameters 4. Autotune overtime. 	<ol style="list-style-type: none"> 1. Replace inverter model. 2. Set up rated parameters according to motor nameplate. 3. Make the motor no load to re-identify the failure. 4. Inspect motor connection, set up parameters
OPSE	System Failure	<ol style="list-style-type: none"> 1. Interference seriously leads to master control board unable to function properly. 2. Ambient noise leads to master control board malfunction. 	<ol style="list-style-type: none"> 1. Press STOP/RST to reset or add power supply filter at the power supply side. 2. Press STOP/RST to reset, ask for service.
EEP	EEPROM failure	<ol style="list-style-type: none"> 1. Control parameters misread-write. 2. EEPROM failure. 	<ol style="list-style-type: none"> 1. Press STOP/RST to reset, ask for service. 2. Ask for service
PIDE	PIDfeedback fail	<ol style="list-style-type: none"> 1. PID feedback disconnected. 2. PID feedback disappears. 	<ol style="list-style-type: none"> 1. Inspect PID feedback signal wire. 2. Examine PID feedback source.
BCE	Brake unit fail	<ol style="list-style-type: none"> 1. Braking circuit failure or brake tube damaged. 2. Too low resistance of externally connected braking resistor 	<ol style="list-style-type: none"> 1. Inspect braking unit, replace braking tube. 2. Increase braking resistance.
	Factory Reserved		

7.2 common failures and solutions

Inverter may have following failures or malfunctions during operation, please refer to following solutions to do simple analysis.

No display after power on:

- Use multimeter to examine whether or not the voltage of power supply is the same as the inverter rated voltage. If the power supply has problem, examine it and eliminate it.
- Examine whether the three-phase rectification bridge is in good condition or not. If the

rectification bridge is burst out, ask for service.

- Check the CHARGE light. If the light is not bright, generally the failure is at the rectification bridge or at the buffer resistor. If the light is bright, the failure may be at the switching power supply. Ask for service.

Power supply air-break switch trip-off when power on:

- Examine whether or not input power supply is grounded or short circuit failure, and eliminate the problem.
- Examine whether the rectification bridge has been burnt or not. If it is damaged, ask for service.

Motor doesn't move while inverter is put in operation

- Inspect if there is balanced three-phase output among U,V,W. If there is, the motor circuit or itself is damaged, or the motor is mechanically locked. Please clear it off.
- There is output but uneven among the three phases, the inverter drive board or the output module is supposed to be damaged, ask for service.
- If there is no output voltage, it may be damage of inverter drive board or the output module, ask for service.

Inverter displays in normal condition, but the power supply air switch trips off after put in operation:

- Examine if there is short circuit of phases between output modules. If there is, ask for service.
- Examine if there is short circuit or ground between motor wires. If there is, eliminate it.
- If the trip-off happens occasionally and the distance between motor and inverter is far, it should be considered to add output AC reactor.

8. Maintenance

	WARNING
<ul style="list-style-type: none"> ●Maintenance must be performed according to designated maintenance methods. ●Maintenance must be performed by qualified people. ●Prior to maintenance, the power supply of inverter must be cut off for ten minutes. ●DO NOT directly touch components or devices on PCB board, otherwise inverter can be damaged by electrostatic. ●After maintenance, all screws must be tightened. 	

8.1 Daily Maintenance

It is necessary to do daily maintenance to avoid inverter fault, ensure failure free operation and extend the inverter's service life. The following table shows daily maintenance contents,

Check Item	Content
Temperature/Humidity	Ensure the environmental temperature is between 0°C ~ 50°C, and humidity is between 20~90%
Oil mist and dust	Ensure there are no oil mist and dust in the inverter.
Inverter	Inspect the inverter to ensure whether there are abnormality heat and vibration.
Fan	Ensure the fan is running well, there is nothing inside to block it.
Input Power	Ensure the input power voltage and frequency are in allowed range.
Motor	Inspect the motor to ensure whether there are abnormality vibration and heat or not, whether there are abnormality noise and phase failure or not.

8.2 Schedule Maintenance

User must inspect the inverter periodically (within half year) to ensure it can be operated for a long time and avoid any failure. Following table indicates the inspection content,

Inspection Item	Inspection Content	Solution
Screw of external terminal	The screws are loose or not.	Tighten up
PC Board	Dust, Dirty object	Clean it by dry compressed air
Fan	Abnormality noise and vibration, cumulative time is over 20,000 hours or not.	Clean it. Replace the fan.
Electrolytic Capacitor	color changed or not, is there any peculiar smell.	Replace electrolytic capacitor.
Heat Sink	Dust, dirty object	Clean it by dry compressed air.
Power Components	Dust, dirty object	Clean them by dry compressed air.

8.3 Replacement of wearing parts

The fans and electrolytic capacitors are wearing parts, please make periodic replacement to ensure long term, safety and failure-free operation. The replacement periods are as follows,

- ◆ Fan: must be replaced when using up to 20,000 hours
- ◆ Electrolytic Capacitor: must be replaced when using up to 30,000~40,000 hours.

8.4 Warranty

The manufacturer warrants its products for a period of 12 months from the date of purchase.

Appendix

CHV series inverter function parameters, which are grouped by functions, have P0-PF total 16 groups among which the PF is the expanded function parameters that user can visit if the inverter has been installed with extension card. Each function group includes a number of function codes, which adopts three-stage menu, for instance, “P8.08” means the 8th function code of P8th function.

For the convenience of setting function code by using operation panel, the function group number is corresponding to Stage 1 menu, the function code is corresponding to Stage 2 menu and the function code parameter is corresponding to Stage 3 menu.

1. The column of function table is described as follows:

The 1st column “Function Code” is the function parameter group and parameter code.

The 2nd column “Name” is the complete name of the function parameter.

The 4th column “Setting Range” is the effective setting value range of the function parameter, shown on the operation panel LCD (liquid crystal display).

The 5th “Default” is the original factory setting value of this function parameter.

The 6th “Modification” is the modification performance of the function parameter (i.e. whether or not it is permitted to modify and the modification conditions), explained as follows,

“○”: indicates that the setting value of this parameter can be modified when the inverter is either in stop or operating status;

“◎”: means that the setting value of this parameter cannot be modified when the inverter is in operating status;

(Inverter has done the automatic detection restriction to the modification performance of each parameter, helping user to prevent mis-modification.)

The 7th column “LCD Display” is the brief description of function parameter name on the operation panel LCD (liquid crystal display);

The 8th column “Serial No.” is the serial number of this function code in the whole function codes, and also is the communication register address.

2. “Parameter Digital System” is the decimal system. If parameters are expressed in hexadecimal system, the value at each digit is independent when the parameter is edited, and the numeric area of some digits can be hexadecimal (0-F).

3. “LCD Display Description” is only valid when using external LCD operation panel.

4. “Default” indicates the value of the function code after it is refreshed while doing the manipulation of restoring the factory parameters; but the actually detected parameters or record values cannot be refreshed.

5. In order to effectively protect the parameters, the inverter provides the cryptoguard for the function code. After the user’s password is set up (i.e. user’s password P7.00 parameter is not 0), when the user press **PRG/ESC** button to enter function code edit status, the system first

enters the user's password verification status, displaying "-----", and the operator must input correctly the user's password, otherwise it is impossible to enter. For the parameters that are factory set up, can enter only if a correct factory password is input as required. (Here remind user DO NOT try to modify the factory parameters, and if the parameters are not set up properly, it can cause inverter malfunction or even damage.) At the state that the cryptoguard is not locked, the user's password can be modified at any time, and the one finally input will be the user's password. If P7.00 is set as 0, the user's password can be cancelled; when the power is on, if P7.00 is not 0, parameters are protected by password. When serial communication is used to modify the function parameters, the function of user's password also follows above rule.

Function Code	Name	Detail Parameter Description	Setting Range	Default	Modification	LCD Display	Serial No.
P0 Group Basic Func							
P0.00	Speed Control Mode	0: V/F control	0	0	☉	Control Mode	0.
P0.01	Operating Command Channel	0: Keypad 1: Terminal 2: Communication	0~2	0	○	Command Select	1.
P0.02	Keyboard and terminal UP/DOWN setting	0: Valid&Store 1: Valid&Unstore 2: Invalid	0~2	0	☉	UP/DOWN	2.
P0.03	A frequency command Selection	0: Keyboard 1: AI1 2: AI3 3: HDI1 4: Simple PLC 5: Multi-speed 6: PID 7: Communication	0~7	0	☉	A Freq Select	3.
P0.04	B frequency command selection	0: AI2 1: AI4 2: HDI2	0~2	0	☉	B Freq Select	4.
P0.05	B frequency reference object selection	0: Max frequency 1: A frequency	0~1	0	○	B Reference	5.
P0.06	Combined mode of setting source	0: A 1: B 2: A+B 3: Max (A, B)	0~3	0	○	Set source comb	6.
P0.07	Maximum output frequency	10.00~600.00Hz	10.00~600.00	50.00 Hz	☉	Max Frequency	7.
P0.08	Upper limit of operation frequency	P0.09~ P0.07	P0.09~ P0.07	50.00 Hz	○	Upper freq limit	8.

Function Code	Name	Detail Parameter Description	Setting Range	Default	Modification	LCD Display	Serial No.
P0.09	Lower limit of operation frequency	0.00 Hz ~ P0.08	0.00~P0.08	0.00Hz	○	Lower freq limit	9.
P0.10	Keypad frequency setting	0.00 Hz ~ P0.08	0.00~P0.08	50.00 Hz	○	Keypad freq set	10.
P0.11	ACC time 0	0.0~3600.0s	0.0~3600.0	20.0s	○	ACC time 0	11.
P0.12	DEC time 0	0.0~3600.0s	0.0~3600.0	20.0s	○	DEC time 0	12.
P0.13	Run direction option	0: Default 1: Reverse 2: Reverse run disabled	0~2	0	◎	Run direction	13.
P0.14	Carrier frequency setting	1.0~16.0kHz	1.0~16.0	Set by model	○	Carrier freq	14.
P0.15	PWM option	0: Fixed PWM 1: Random PWM	0~1	0	○	PWM option	15.
P0.16	Carrier frequency adjustment Option	0: Unchange by temperature 1: Change by temperature	0~1	0	◎	Carrier freq Adj	16.
P0.17	Autotune of motor parameters	0: Disabled 1: Enabled	0~1	0	◎	Para autotune	17.
P0.18	Function parameters restore	0: Disabled 1: Restore default 2: Del failure	0~2	0	◎	Para restore	18.
P1 Group RUN/STOP Ctrl							
P1.00	Start Mode	0: Soft start 1: DC brake first 2: Speed pickup	0~2	0	◎	Start mode	19.
P1.01	Direct start frequency	0.00~10.00Hz	0.00~10.00	0.00Hz	◎	Start frequency	20.
P1.02	Hold time of starting frequency	0.0~50.0s	0.0~50.0	0.0s	◎	Start hold time	21.
P1.03	Braking current before starting	0.0~150.0%	0.0~150.0	0.0%	◎	Start Brak curr	22.
P1.04	Braking time before starting	0.0~50.0s	0.0~50.0	0.0s	◎	Start Brak time	23.
P1.05	ACC/DEC mode options	0: Linear 1: S curve	0~1	0	◎	ACC/DEC mode	24.
P1.06	S curve beginning stage scale	0.0~40.0% (ACC/DEC time)	0.0~40.0	30.0%	◎	S curve start	25.
P1.07	S curve ending stage scale	0.0~40.0% (ACC/DEC time)	0.0~40.0	30.0%	◎	S curve end	26.
P1.08	Stop Mode Option	0: DEC to Stop 1: Coast to Stop	0~1	0	○	Stop Mode	27.

Function Code	Name	Detail Parameter Description	Setting Range	Default	Modification	LCD Display	Serial No.
P1.09	Beginning Frequency of braking stop	0.00~10.00Hz	0.00~10.00	0.00Hz	○	Brake start freq	28.
P1.10	Waiting time of braking stop	0.0~50.0s	0.0~50.0	0.0s	○	Brake wait time	29.
P1.11	DC braking current	0.0~150.0%	0.0~150.0	0.0%	○	Brake current	30.
P1.12	DC braking time	0.0~50.0s	0.0~50.0	0.0s	○	Brake time	31.
P1.13	Dead time between forward and reverse	0.0~3600.0s	0.0~3600.0	0.0s	○	F/R dead time	32.
P1.14	Act if operating Frequency is less than lower frequency limit (Valid if the lower limit is more than 0)	0: Run at lower freq limit 1: Stop 2: Dormancy & stand-by	0~2	0	◎	Lower freq limit	33.
P1.15	Power-back restart option	0: Restart disabled 1: Restart enabled	0~1	0	○	Power restart	34.
P1.16	Restart waiting time	0.0~3600.0s	0.0~3600.0	0.0s	○	Waiting time	35.
P2 Group Motor Para							
P2.00	Inverter model	0: Constant torq 1: Variable torq	0~1	Set by model	●	Inverter model	36.
P2.01	Motor rated frequency	0.01Hz~P0.07	0.01~P0.07	50.00 Hz	◎	Rated frequency	37.
P2.02	Motor rated speed	0~36000rpm	0~36000	1460rpm	◎	Rated speed	38.
P2.03	Motor rated voltage	0~440V	0~440	380V	◎	Rated voltage	39.
P2.04	Motor rated current	0.1~1000.0A	0.1~1000.0	Set by model	◎	Rated current	40.
P2.05	Motor rated power	0.4~900.0kW	0.4~900.0	Set by model	◎	Rated power	41.
P2.06	Motor stator resistance	0.001~65.535 Ω	0.001~65.535	Set by model	○	Stator resist	42.
P2.07	Motor rotor resistance	0.001~65.535 Ω	0.001~65.535	Set by model	○	Rotor resist	43.
P2.08	Motor stator/rotor inductance	0.1~6553.5mH	0.1~6553.5	Set by model	○	Stat/rot induct	44.
P2.09	Mutual inductance of motor stator/rotor	0.1~6553.5mH	0.1~6553.5	Set by model	○	S/R mut induct	45.



Function Code	Name	Detail Parameter Description	Setting Range	Default	Modification	LCD Display	Serial No.
P2.10	Motor no-load current	0.01 ~ 655.35A	0.01 ~ 655.35	Set by model	○	No-load current	46.
P3 Group Reserved							
P4 Group V/F Control							
P4.00	V/F curve setting	0: Linear 1: Multipoint 2: 1.3 order decreasing torque 3: 1.7 order decreasing torque 4: 2.0 order decreasing torque	0~4	0	◎	V/F curve set	47.
P4.01	Torque boost	0.0%: auto 0.1%~30.0%	0.0~30.0	1.0%	○	Torque boost	48.
P4.02	Torque boost cut-off point	0.0%~50.0% (Rated freq)	0.0~50.0	20.0%	◎	Torq bst cut-off	49.
P4.03	V/F Frequency Point 1	0.00Hz~ P4.05	0.00~P4.05	5.00Hz	◎	V/F freq 1	50.
P4.04	V/F Voltage Point 1	0.0%~100.0%	0.0~100.0	10.0%	◎	V/F voltage 1	51.
P4.05	V/F Frequency Point 2	P4.03~ P4.07	P4.03~P4.07	30.00 Hz	◎	V/F freq 2	52.
P4.06	V/F Voltage Point 2	0.0%~100.0%	0.0~100.0	60.0%	◎	V/F voltage 2	53.
P4.07	V/F Frequency Point 3	P4.05~ P2.01	P4.05~P2.01	50.00 Hz	◎	V/F freq 3	54.
P4.08	V/F Voltage Point 3	0.0%~100.0%	0.0~100.0	100.0 %	◎	V/F voltage 3	55.
P4.09	V/F slip compensation range	0.00~10.00Hz	0.00~10.00	0.0Hz	○	V/F slip comp	56.
P4.10	AVR function option	0: Invalid 1: Valid 2: Invalid in deceleration	0~2	1	○	AVR option	57.
P4.11	Energy-saving operation option	0: Disabled 1: Enabled	0~1	0	○	Energy-save oper	58.
P4.12	Reserved function	0~1	0~1	0	○	Reserved	59.
P5 Group Input							
P5.00	HDI input type option	0: Both pulse 1: HDI1 is DI HDI2 is pulse 2: HDI2 is DI HDI1 is pulse 3: Both DI	0~3	0	◎	HDI type	60.
P5.01	Terminal function input option	0: DI 1: Communication	0~1	0	◎	Terminal option	61.

Function Code	Name	Detail Parameter Description	Setting Range	Default	Modification	LCD Display	Serial No.
P5.02	S1 Terminal Function Selection	0: No function 1: Forward 2: Reverse 3: 3-wire control 4: Forward Jog 5: Reverse Jog 6: Coast to stop 7: Failure reset 8: Running pause 9: External fault 10: Freq up 11: Freq down 12: Freq up clr 13: Switch setting A and B 14: Switch setting A and A+B 15: Switch setting B and A+B 16: Multi-Speed 1 17: Multi-Speed 2 18: Multi-Speed 3 19: Multi-Speed 4 20: Multi-speed pause 21: ACC/DEC Time1 22: ACC/DEC Time 2 23: PLC reset 24: PLC pause 25: PID pause 26: Traverse pause 27: Traverse reset 28: Counter reset 29: Length reset 30: ACC/DEC disabled 31: Torque control disabled 32-47: Reserved	0~39	1	☉	S1 function	62.
P5.03	S2 Terminal Function Selection		0~39	4	☉	S2 function	63.
P5.04	S3 Terminal Function Selection		0~39	7	☉	S3 function	64.
P5.05	S4 Terminal Function Selection		0~39	0	☉	S4 function	65.
P5.06	S5 Terminal Function Selection		0~39	0	☉	S5 function	66.
P5.07	HDI1 terminal on-off input function selection		0~39	0	☉	HDI1 function	67.
P5.08	HDI2 terminal on-off input function selection		0~39	0	☉	HDI2 function	68.
P5.09	S6 Terminal Function Selection		0~39	0	☉	S6 function	69.
P5.10	S7 Terminal Function Selection		0~39	0	☉	S7 function	70.
P5.11	S8 Terminal Function Selection		0~39	0	☉	S8 function	71.
P5.12	DI signal filtering times	1~10	1~10	5	○	DI filter times	72.
P5.13	Terminal control mode	0: 2-wire mode1 1: 2-wire mode2 2: 3-wire mode1 3: 3-wire mode2	0~3	0	☉	DI control mode	73.
P5.14	UP/DOWN Terminal UP/DOWN frequency increment variable rate	0.01~50.00Hz/s	0.01~50.00	0.50Hz/s	○	Freq var rate	74.
P5.15	AI1 lower limit	0.00V~10.00V	0.00~10.00	0.00V	○	AI1 lower limit	75.
P5.16	AI1 lower limit corresponding setting	-100.0%~100.0%	-100.0~100.0	0.0%	○	AI1 L limit set	76.

Function Code	Name	Detail Parameter Description	Setting Range	Default	Modification	LCD Display	Serial No.
P5.17	AI1 upper limit	0.00V~10.00V	0.00~10.00	10.00V	○	AI1 upper limit	77.
P5.18	AI1 upper limit corresponding setting	-100.0%~100.0%	-100.0~100.0	100.0%	○	AI1 U limit set	78.
P5.19	AI1 input filtering time	0.00s~10.00s	0.00~10.00	0.10s	○	AI1 filter time	79.
P5.20	AI2 lower limit	0.00V~10.00V	0.00~10.00	0.00V	○	AI2 lower limit	80.
P5.21	AI2 lower limit corresponding setting	-100.0%~100.0%	-100.0~100.0	0.0%	○	AI2 L limit set	81.
P5.22	AI2 upper limit	0.00V~10.00V	0.00~10.00	10.00V	○	AI2 upper limit	82.
P5.23	AI2 upper limit corresponding setting	-100.0%~100.0%	-100.0~100.0	100.0%	○	AI2 U limit set	83.
P5.24	AI2 input filtering time	0.00s~10.00s	0.00~10.00	0.10s	○	AI2 filter time	84.
P5.25	AI3 lower limit	-10.00V ~10.00V	-10.00~10.00	0.00V	○	AI3 lower limit	85.
P5.26	AI3 lower limit corresponding setting	-100.0%~100.0%	-100.0~100.0	0.0%	○	AI3 L limit set	86.
P5.27	AI3 upper limit	-10.00V ~10.00V	-10.00~10.00	10.00V	○	AI3 upper limit	87.
P5.28	AI3 upper limit corresponding setting	-100.0%~100.0%	-100.0~100.0	100.0%	○	AI3 U limit set	88.
P5.29	AI3 input filtering time	0.00s~10.00s	0.00~10.00	0.10s	○	AI3 filter time	89.
P5.30	AI4 lower limit	0.00V~10.00V	0.00~10.00	0.00V	○	AI4 lower limit	90.
P5.31	AI4 lower limit corresponding setting	-100.0%~100.0%	-100.0~100.0	0.0%	○	AI4 L limit set	91.
P5.32	AI4 upper limit	0.00V~10.00V	0.00~10.00	10.00V	○	AI4 upper limit	92.
P5.33	AI4 upper limit corresponding setting	-100.0%~100.0%	-100.0~100.0	100.0%	○	AI4 U limit set	93.
P5.34	AI4 input filtering time	0.00s~10.00s	0.00~10.00	0.10s	○	AI4 filter time	94.
P5.35	HDI1 high speed pulse input function options	0: Setting 1: Counter 2: Length	0~4	0	◎	HDI1 pulse func	95.

Function Code	Name	Detail Parameter Description	Setting Range	Default	Modification	LCD Display	Serial No.
P5.36	HDI2 high speed pulse input function options	3: Reserved 4: Reserved	0~4	0	⊙	HDI2 pulse func	96.
P5.37	HDI1 lower limit frequency	0.0 KHz ~50.0KHz	0.0~50.0	0.0KHz	○	HDI1 L limit fre	97.
P5.38	HDI1 lower limit frequency corresponding setting	-100.0%~100.0%	-100.0~100.0	0.0%	○	HDI1 L limit set	98.
P5.39	HDI1 upper limit frequency	0.0 KHz ~50.0KHz	0.0~50.0	50.0KHz	○	HDI1 U limit fre	99.
P5.40	HDI1 upper limit frequency corresponding setting	-100.0%~100.0%	-100.0~100.0	100.0%	○	HDI1 U limit set	100.
P5.41	HDI1 frequency input filtering time	0.00s~10.00s	0.00~10.00	0.10s	○	HDI1 filter time	101.
P5.42	HDI2 lower limit frequency	0.0 KHz ~50.0KHz	0.0~50.0	0.0KHz	○	HDI2 L limit fre	102.
P5.43	HDI2 lower limit frequency corresponding setting	-100.0%~100.0%	-100.0~100.0	0.0%	○	HDI2 L limit set	103.
P5.44	HDI2 upper limit frequency	0.0 KHz ~50.0KHz	0.0~50.0	50.0KHz	○	HDI2 U limit fre	104.
P5.45	HDI2 upper limit frequency corresponding setting	-100.0%~100.0%	-100.0~100.0	100.0%	○	HDI2 U limit set	105.
P5.46	HDI2 frequency input filtering time	0.00s~10.00s	0.00~10.00	0.10s	○	HDI2 filter time	106.
P6 Group Output							
P6.00	HDO output type	0: HDO 1: Open collector	0~1	0	⊙	HDO type	107.
P6.01	Y1 output option	0: NO output 1: Run forward 2: Run reverse 3: Malfunction 4: Motor overload 5: Inverter overload 6: FDT out 7: Freq reach 8: Zero speed run 9: Set Count reach 10: Assign count reach 11: Length reach 12: PLC finish	0~25	1	○	Y1 output opt	108.
P6.02	Y2 output option		0~25	0	○	Y2 output opt	109.
P6.03	HDO open collector output option		0~25	0	○	Open output opt	110.
P6.04	Relay 1 output option		0~25	3	○	R1 output opt	111.
P6.05	Relay 2 output option		0~25	0	○	R2 output opt	112.

Function Code	Name	Detail Parameter Description	Setting Range	Default	Modification	LCD Display	Serial No.
P6.06	Relay 3 output option	13: Running time reach 14: Upper freq limit reach 15: Lower freq limit reach 16: Ready to run 17: Start motor1 18: Start motor2 19-25: Reserved	0~25	0	○	R3 output opt	113.
P6.07	AO1 output option	0: Running freq 1: Setting freq 2: Running speed 3: Output current 4: Output voltage 5: Output power 6: Output torque 7: AI1 value 8: AI2 value 9: AI3 value 10: AI4 value 11: HDI1 value 12: HDI2 value 13: Length value 14: Count value 15-20 Reserved	0~20	0	○	AO1 output opt	114.
P6.08	AO2 output option		0~20	0	○	AO2 output opt	115.
P6.09	HDO open collector high speed pulse output option		0~20	0	○	Pulse output opt	116.
P6.10	Lower output limit 1	0.0%~100.0%	0.0~100.0	0.0%	○	Lower limit 1	117.
P6.11	Lower limit corresponding AO1 output	0.00V ~10.00V	0.00~10.00	0.00V	○	L limit to AO1	118.
P6.12	Upper Output Limit 1	0.0%~100.0%	0.0~100.0	100.0%	○	Upper limit 1	119.
P6.13	Upper limit corresponding AO1 output	0.00V ~10.00V	0.00~10.00	10.00V	○	U limit to AO1	120.
P6.14	Lower Output Limit 2	0.0%~100.0%	0.0~100.0	0.0%	○	Lower limit 2	121.
P6.15	Lower limit corresponding AO2 output	0.00V ~10.00V	0.00~10.00	0.00V	○	L limit to AO2	122.
P6.16	Upper Output Limit 2	0.0%~100.0%	0.0~100.0	100.0%	○	Upper limit 2	123.
P6.17	Upper limit corresponding AO2 output	0.00V ~10.00V	0.00~10.00	10.00V	○	U limit to AO2	124.
P6.18	Lower Output Limit 3	0.0%~100.0%	0.0~100.0	0.0%	○	Lower limit 3	125.
P6.19	Lower limit corresponding HDO output	0.0 ~ 50.0kHz	0.0~50.0	0.0kHz	○	L limit to HDO	126.

Function Code	Name	Detail Parameter Description	Setting Range	Default	Modification	LCD Display	Serial No.
P6.20	Upper Output Limit 3	0.0%~100.0%	0.0~100.0	100.0%	○	Upper limit 3	127.
P6.21	Upper limit corresponding HDO output	0.0 ~ 50.0kHz	0.0~50.0	50.0kHz	○	U limit to HDO	128.
P7 Group Operate Inter							
P7.00	User password	0~65535	0~65535	0	○	User password	129.
P7.01	LCD display language option	0: Chinese 1: English	0~1	0	○	Language option	130.
P7.02	Function parameter copying	0: No operation 1: Upload 2: Download	0~2	0	◎	Parameter copy	131.
P7.03	QUICK/JOG button function option	0: QUICK function 1: FDW/REV switch 2: Jog operation 3: Clear UP/DOWN	0~3	0	◎	Quick/JOG func	132.
P7.04	STOP/RST button stop function option	0: Valid to panel 1: Valid to panel and terminal 2: Valid to panel & communication 3: Valid to all	0~3	0	○	STOP/RST func	133.
P7.05	Keypad display option	0: Option 0 1: Option 1 2: Option 2 3: Option 3	0~3	0	○	Keypad display	134.
P7.06	Operation status display parameter option	1. Running freq 2. Setting freq 3. Bus voltage 4. Output voltage 5. Output current Other parameters display is affected by this function code BIT0: Running speed BIT1: Output power BIT2: Output torque BIT3: PID setpoint BIT4: PID feedback BIT5: In terminal status BIT6: Out terminal status BIT7: AI1 BIT8: AI2 BIT9: AI3 BIT10: AI4 BIT11: HDI1 BIT12: HDI2 BIT13: Multi-speed steps BIT14: Length BIT15: Counting value	0~65535	255	○	Operate display	135.

Function Code	Name	Detail Parameter Description	Setting Range	Default	Modification	LCD Display	Serial No.
P7.07	Stop status display parameter option	BIT0: Setting freq BIT1: Bus voltage BIT2: In terminal status BIT3: Out terminal status BIT4: PID setpoint BIT5: PID feedback BIT6: AI1 BIT7: AI2 BIT8: AI3 BIT9: AI4 BIT10: HDI1 BIT11: HDI2 BIT12: Curr multi-speed step BIT13: Length BIT14: Reserved BIT15: Reserved	1~65535	255	○	Stop display	136.
P7.08	Diode module temperature	0~100.0℃			●	Diode Temperatur	137.
P7.09	IGBT module temperature	0~100.0℃			●	IGBT temperature	138.
P7.10	MCU software version				●	MCU software ver	139.
P7.11	DSP software version				●	DSP software ver	140.
P7.12	Local inverter accumulative run time	0~65535h			●	Accumul run time	141.
P7.13	Third latest fault type	0: No fault 1: OUT1 2: OUT2 3: OUT3 4: OC1 5: OC2 6: OC3 7: OV1 8: OV2 9: OV3 10: UV 11: OL1 12: OL2			●	3rd latest fault	142.
P7.14	Second latest fault type				●	2nd latest fault	143.

Function Code	Name	Detail Parameter Description	Setting Range	Default	Modification	LCD Display	Serial No.
P7.15	Latest fault type	13: SPI 14: SPO 15: OH1 16: OH2 17: EF 18: CF 19: ITE 20: TE 21: PCE 22: PCDE 23: OPSE 24: EEP 25: PIDE 26: BCE 27: Reserved			●	Latest fault	144.
P7.16	Current fault operating frequency				●	Freq at fault	145.
P7.17	Current fault output amperage				●	Current at fault	146.
P7.18	Current fault DC bus voltage				●	DC volt at fault	147.
P7.19	Current fault input terminal status				●	Fault input	148.
P7.20	Current fault output terminal status				●	Fault output	149.
P8 Group Enhance Func							
P8.00	ACC Time 1	0.0~3600.0s	0.0~3600.0	20.0s	○	ACC time 1	150.
P8.01	DEC Time 1	0.0~3600.0s	0.0~3600.0	20.0s	○	DEC time 1	151.
P8.02	ACC Time 2	0.0~3600.0s	0.0~3600.0	20.0s	○	ACC time 2	152.
P8.03	DEC Time 2	0.0~3600.0s	0.0~3600.0	20.0s	○	DEC time 2	153.
P8.04	ACC Time 3	0.0~3600.0s	0.0~3600.0	20.0s	○	ACC time 3	154.
P8.05	DEC Time 3	0.0~3600.0s	0.0~3600.0	20.0s	○	DEC time 4	155.
P8.06	Jogging operation frequency	0.00~ P0.07	0.00~ P0.07	5.00Hz	○	Jog oper freq	156.
P8.07	Jogging operation ACCEL time	0.0~3600.0s	0.0~3600.0	20.0s	○	Jog ACC time	157.
P8.08	Jogging operation DECEL time	0.0~3600.0s	0.0~3600.0	20.0s	○	Jog DEC time	158.
P8.09	Skip frequency 1	0.00~P0.07	0.00~P0.07	0.00Hz	○	Skip freq 1	159.

Function Code	Name	Detail Parameter Description	Setting Range	Default	Modification	LCD Display	Serial No.
P8.10	Skip frequency 2	0.00~P0.07	0.00~P0.07	0.00Hz	○	Skip freq 2	160.
P8.11	Skip frequency range	0.00~P0.07	0.00~P0.07	0.00Hz	○	Skip freq range	161.
P8.12	Traverse frequency range	0.0~100.0%	0.0~100.0	0.0%	○	Traverse range	162.
P8.13	Kick frequency range	0.0~50.0%	0.0~50.0	0.0%	○	Kick freq range	163.
P8.14	Traverse frequency up time	0.1~3600.0s	0.1~3600.0	5.0s	○	Traverse UP time	164.
P8.15	Traverse frequency down time	0.1~3600.0s	0.1~3600.0	5.0s	○	Traverse DN time	165.
P8.16	Fault auto-reset times	0~3	0~3	0	○	Fault RST times	166.
P8.17	Fault relay actuated during auto fault reset	0:Disabled 1: Enabled	0~1	0	○	Fault action opt	167.
P8.18	Interval time setting of auto reset fault	0.1~100.0s	0.1~100.0	1.0s	○	Fault RST intrvl	168.
P8.19	Set Length	1~65535	1~65535	1000	○	Set length	169.
P8.20	Actual Length	0~65535	0~65535	0	○	Actual length	170.
P8.21	Pulse Number unit	0.1~6553.5	0.1~6553.5	100.0	○	Pulse num unit	171.
P8.22	Set count value	1~65535	1~65535	1000	○	Set count	172.
P8.23	Assign count value	1~65535	1~65535	1000	○	Assign count	173.
P8.24	Set run time	0~65535h	0~65535	65535h	○	Set run time	174.
P8.25	FDT level detection value	0.00~ P0.07	0.00~P0.07	50.00 Hz	○	FDT level	175.
P8.26	FDT delay detection value	0.0~100.0%	0.0~100.0	5.0%	○	FDT delay	176.
P8.27	Frequency reach detection range	0.0~100.0%	0.0~100.0	0.0%	○	Freq reach detect	177.
P8.28	Droop control	0.00~10.00Hz	0.00~10.00	0.00Hz	○	Droop control	178.

Function Code	Name	Detail Parameter Description	Setting Range	Default	Modification	LCD Display	Serial No.
P8.29	Auxiliary motor validity option	0: No auxiliary motor 1: Auxiliary motor 1 2: Auxiliary motor 2 3: Both motor 1&2	0~3	0	☉	Auxiliary motor	179.
P8.30	Auxiliary motor 1 START/STOP delay time	0.0~3600.0s	0.0~3600.0	5.0s	○	Delay time 1	180.
P8.31	Auxiliary motor 2 START/STOP delay time	0.0~3600.0s	0.0~3600.0	5.0s	○	Delay time 2	181.
P8.32	Brake Threshold Value Voltage	550.0~750.0V	550.0~750.0	700.0 V	○	Braking voltage	182.
P8.33	Reserved Function	0~65535	0~65535	0	○	Reserved	183.
P8.34	Reserved Function	0~65535	0~65535	0	○	Reserved	184.
P9 Group PID Control							
P9.00	PID setpoint sources Option	0: Keypad 1: AI1 2: AI2 3: AI3 4: AI4 5: HDI1 6: HDI2 7: Communication 8: PLC	0~8	0	○	PID setpoint	185.
P9.01	Keyboard preset PID Assignment	0.0%~100.0%	0.0~100.0	0.0%	○	Preset PID	186.
P9.02	PID Feedback Sources Option	0: AI1 1: AI2 2: AI3 3: AI4 4: AI1-AI2 5: AI3-AI4 6: HDI1 7: HDI2 8: HDI1-HDI2 9: Communication	0~9	0	○	PID feedback	187.
P9.03	PID Output Characteristics Option	0: Positive 1: Negative	0~1	0	○	PID characterist	188.
P9.04	Proportional gain (Kp)	0.00~100.00	0.00~100.00	0.10	○	Proportion gain	189.

Function Code	Name	Detail Parameter Description	Setting Range	Default	Modification	LCD Display	Serial No.
P9.05	Integral time (Ti)	0.01~10.00s	0.01~10.00	0.10s	○	Integral time	190.
P9.06	Differential time (Td)	0.00~10.00s	0.00~10.00	0.00s	○	Differentia time	191.
P9.07	Sampling cycle time (T)	0.01~100.00s	0.01~100.00	0.50s	○	Sampling cycle	192.
P9.08	PID control bias limit	0.0~100.0%	0.0~100.0	0.0%	○	PID bias. limit	193.
P9.09	PID output buffering time	0.00~10.00s	0.00~10.00	0.00	○	PID buffer time	194.
P9.10	Feedback broke detecting value	0.0~100.0%	0.0~100.0	0.0%	○	FB broke value	195.
P9.11	Feedback broke detecting time	0.0~3600.0s	0.0~3600.0	1.0s	○	FB broke time	196.
PA Group Multi-Speed							
PA.00	Simple PLC operation mode	0: Stop after running once 1: keep running at the final value after running once 2: running in cycle	0~2	0	○	Simple PLC mode	197.
PA.01	Simple PLC memory option	0: no memory while power down 1: memorize while power down	0~1	0	○	PLC memory opt	198.
PA.02	Multi-Speed 0	-100.0~100.0%	-100.0~100.0	0.0%	○	Multi-speed 0	199.
PA.03	0 th Stage operating time	0.0~6553.5s(h)	0.0~6553.5	0.0s	○	0 th stage time	200.
PA.04	Multi-Speed 1	-100.0~100.0%	-100.0~100.0	0.0%	○	Multi-speed 1	201.
PA.05	1 st Stage operating time	0.0~6553.5s(h)	0.0~6553.5	0.0s	○	1 st stage time	202.
PA.06	Multi-Speed 2	-100.0~100.0%	-100.0~100.0	0.0%	○	Multi-speed 2	203.
PA.07	2 nd Stage operating time	0.0~6553.5s(h)	0.0~6553.5	0.0s	○	2 nd stage time	204.
PA.08	Multi-Speed 3	-100.0~100.0%	-100.0~100.0	0.0%	○	Multi-speed 3	205.
PA.09	3 rd Stage operating time	0.0~6553.5s(h)	0.0~6553.5	0.0s	○	3 rd stage time	206.
PA.10	Multi-Speed 4	-100.0~100.0%	-100.0~100.0	0.0%	○	Multi-speed 4	207.
PA.11	4 th Stage operating time	0.0~6553.5s(h)	0.0~6553.5	0.0s	○	4 th stage time	208.



Function Code	Name	Detail Parameter Description	Setting Range	Default	Modification	LCD Display	Serial No.
PA.12	Multi-Speed 5	-100.0~100.0%	-100.0~100.0	0.0%	○	Multi-speed 5	209.
PA.13	5 th Stage operating time	0.0~6553.5s(h)	0.0~6553.5	0.0s	○	5 th stage time	210.
PA.14	Multi-Speed 6	-100.0~100.0%	-100.0~100.0	0.0%	○	Multi-speed 6	211.
PA.15	6 th Stage operating time	0.0~6553.5s(h)	0.0~6553.5	0.0s	○	6 th stage time	212.
PA.16	Multi-Speed 7	-100.0~100.0%	-100.0~100.0	0.0%	○	Multi-speed 7	213.
PA.17	7 th Stage operating time	0.0~6553.5s(h)	0.0~6553.5	0.0s	○	7 th stage time	214.
PA.18	Multi-Speed 8	-100.0~100.0%	-100.0~100.0	0.0%	○	Multi-speed 8	215.
PA.19	8 th Stage operating time	0.0~6553.5s(h)	0.0~6553.5	0.0s	○	8 th stage time	216.
PA.20	Multi-Speed 9	-100.0~100.0%	-100.0~100.0	0.0%	○	Multi-speed 9	217.
PA.21	9 th Stage operating time	0.0~6553.5s(h)	0.0~6553.5	0.0s	○	9 th stage time	218.
PA.22	Multi-Speed 10	-100.0~100.0%	-100.0~100.0	0.0%	○	Multi-speed 10	219.
PA.23	10 th Stage operating time	0.0~6553.5s(h)	0.0~6553.5	0.0s	○	10 th stage time	220.
PA.24	Multi-Speed 11	-100.0~100.0%	-100.0~100.0	0.0%	○	Multi-speed 11	221.
PA.25	11 th Stage operating time	0.0~6553.5s(h)	0.0~6553.5	0.0s	○	11 th stage time	222.
PA.26	Multi-Speed 12	-100.0~100.0%	-100.0~100.0	0.0%	○	Multi-speed 12	223.
PA.27	12 th Stage operating time	0.0~6553.5s(h)	0.0~6553.5	0.0s	○	12 th stage time	224.
PA.28	Multi-Speed 13	-100.0~100.0%	-100.0~100.0	0.0%	○	Multi-speed 13	225.
PA.29	13 th Stage operating time	0.0~6553.5s(h)	0.0~6553.5	0.0s	○	13 th stage time	226.
PA.30	Multi-Speed 14	-100.0~100.0%	-100.0~100.0	0.0%	○	Multi-speed 14	227.
PA.31	14 th Stage operating time	0.0~6553.5s(h)	0.0~6553.5	0.0s	○	14 th stage time	228.
PA.32	Multi-Speed 15	-100.0~100.0%	-100.0~100.0	0.0%	○	Multi-speed 15	229.

Function Code	Name	Detail Parameter Description	Setting Range	Default	Modification	LCD Display	Serial No.
PA.33	15 th Stage operating time	0.0~6553.5s(h)	0.0~6553.5	0.0s	○	15 th stage time	230.
PA.34	Simple PLC Stage 0-7 ACCEL/DECEL Time Option	0~65535	0~63353	0	○	ACC/DEC time 0-7	231.
PA.35	Simple PLC Stage 8-15 ACCEL/DECEL Time Option	0~65535	0~65535	0	○	ACC/DEL time8-15	232.
PA.36	Multistage Time Unit Option	0: Second 1: Hour	0~1	0	◎	Time unit opt	233.
Pb Group Protect Para							
Pb.00	Input phase-failure protection	0: Disabled 1: Enabled	0~1	1	○	SPI protect opt	234.
Pb.01	Output phase-failure protection	0: Disabled 1: Enabled	0~1	1	○	SPO protect opt	235.
Pb.02	Motor Overload Protection Option	0: No protection 1: Normal motor 2: VVVF motor	0~2	1	◎	OL1 protect opt	236.
Pb.03	Motor Overload Protection Current	20.0%~120.0%	20.0~120.0	100.0%	○	OL1 protect curr	237.
Pb.04	Overload pre-warning point	20.0%~150.0%	20.0~150.0	130.0%	○	Overload prewarn	238.
Pb.05	Overload pre-warning option	0: relative to motor rated current, detected all the time 1: relative to motor rated current, detected when speed is constant 2: relative to inverter rated current, detected all the time 3: relative to inverter rated current, detected when speed is constant	0~3	0	◎	Overload warn opt	239.
Pb.06	Overload pre-warning delay time	0.0~30.0s	0.0~30.0	5.0s	○	Warn delay time	240.
Pb.07	Instant Poweroff Frequency Down Point	400.0V~600.0V	400.0~600.0	450.0V	○	Pwroff DEC point	241.
Pb.08	Instant poweroff Frequency drop rate	0.00Hz~P0.07	0.00Hz~P0.07	0.00Hz	○	Poweroff Freq	242.
Pb.09	Over-voltage Stall Protection	0: Disabled 1: Enabled	0~1	0	○	OV stall Protect	243.
Pb.10	Over-voltage Stall Protection Voltage	120~150%	120~150	130%	○	OV stall Voltage	244.

Function Code	Name	Detail Parameter Description	Setting Range	Default	Modification	LCD Display	Serial No.
Pb.11	Over-current Stall Protection	0: Disabled 1: Enabled	0~1	0	○	OC Stall Protect	245.
Pb.12	Over-current Stall Protection Current	100~200%	100~200	150%	○	OC Stall Current	246.
Pb.13	Over-current Frequency Drop Rate	0.00~50.00Hz/s	0.00~50.00	0.00Hz/s	○	OC freq droprate	247.
PC Group Communication							
PC.00	Local Inverter Communication Address	1-247, 0: broadcast address	1~247	1	○	Local comm addr	248.
PC.01	Communication baud rate setting	0: 1200BPS 1: 2400BPS 2: 4800BPS 3: 9600BPS 4: 19200BPS 5: 38400BPS	0~5	3	○	Baud rate	249.
PC.02	Data bit check setting	0: Null (N, 8, 2) 1: Even (E, 8, 1) 2: Odd (O, 8, 1)	0~2	0	○	Bit check	250.
PC.03	Communication response delay	0~20ms	0~20	0	○	Response delay	251.
PC.04	Communication overtime fault time	0.0 (invalid) , 0.1~100.0s	0.0~100.0	0.0s	○	Comm overtime	252.
PC.05	Reserved function	0~1	0~1	0	○	Reserved	253.
PC.06	Reserved function	0~65535	0~65535	0	◎	Reserved	254.
PC.07	Reserved function	0~65535	0~65535	0	◎	Reserved	255.
PC.08	Reserved function	0~65535	0~65535	0	◎	Reserved	256.
PC.09	Reserved function	0~65535	0~65535	0	◎	Reserved	257.
Pd Group Reserved Func							
Pd.00	Reserved function	0~65535	0~65535	0	◎	Reserved	258.
Pd.01	Reserved function	0~65535	0~65535	0	◎	Reserved	259.
Pd.02	Reserved function	0~65535	0~65535	0	◎	Reserved	260.
Pd.03	Reserved function	0~65535	0~65535	0	◎	Reserved	261.
Pd.04	Reserved function	0~65535	0~65535	0	◎	Reserved	262.



Function Code	Name	Detail Parameter Description	Setting Range	Default	Modification	LCD Display	Serial No.
Pd.05	Reserved function	0~65535	0~65535	0	⊙	Reserved	263.
Pd.06	Reserved function	0~65535	0~65535	0	⊙	Reserved	264.
Pd.07	Reserved function	0~65535	0~65535	0	⊙	Reserved	265.
Pd.08	Reserved function	0~65535	0~65535	0	⊙	Reserved	266.
Pd.09	Reserved function	0~65535	0~65535	0	⊙	Reserved	267.
PE Group Factory Func							
PE.00	Factory Password	0~65535	0~65535	*****	●	Factory password	268.
PF Group Expanded Func							
PF.00 ~ PF.99	For details, please refer to related product description						296 ~ 395